

TECHNICAL MANUAL
OPERATOR'S, UNIT AND
DIRECT SUPPORT MAINTENANCE MANUAL
(INCLUDING REPAIR PARTS AND SPECIAL TOOLS LIST)
FOR

LABLINE EXPLOSION PROOF REFRIGERATOR
(MODEL 3557)

This technical manual is an authentication of the manufacturer's commercial literature and does not conform with the format and the content requirements normally associated with Army technical manuals. This technical manual does, however, contain all essential information required to operate and maintain the equipment.

Approved for public release; distribution is unlimited.

HEADQUARTERS, DEPARTMENT OF THE ARMY

28 SEPTEMBER 1990

This technical manual is an authentication of the manufacturer's commercial literature and does not conform with the format and the content requirements normally associated with Army technical manuals. This technical manual does, however, contain all essential information required to operate and maintain the equipment.

Approved for public release; distribution is unlimited.

SUPPLEMENTARY INTRODUCTORY MATERIAL

I-1. Maintenance Forms and Records.

Department of the Army forms and Procedures used for equipment maintenance will be those described by DA Pam 738-750, The Army Maintenance Management System.

1-2. Reporting Errors and Recommending Improvements.

You can help improve this manual. If you find any mistakes or if you know of a way to improve the procedures, please let us know. Mail your letters, DA Form 2028 (Recommended Changes to Publications and Blank Forms), or DA Form 2028-2 located in the back of this manual, directly to: Commander, U.S. Army Troop Support Command, ATTN: AMSTR-MCTS, 4300 Goodfellow Blvd., St. Louis, MO 63120-1798. A reply will be furnished to you.

1-3. Destruction of Army Material to Prevent Enemy Use.

Refer to TM 750-244-3 for instructions covering the destruction of Army Material to prevent enemy use.

1-4. Administrative Storage of Equipment.

a. Placement of equipment in administrative storage should be for short periods of time when a shortage of maintenance effort exists. Items should be in mission readiness within 24 hours or within the time factors as determined by the directing authority. During the storage period appropriate maintenance records will be kept.

b. Before placing equipment in administrative storage, current preventive maintenance checks and services should be completed. Shortcomings and deficiencies should be corrected, and all modification work orders (MWO'S) should be applied.

c. Storage site selection. Inside storage is preferred for items selected for administrative storage. If inside storage is not available, trucks, vans, conex containers and other containers may be used.

OPERATION MANUAL



LAB-LINE
EXPLOSION-PROOF FRIGID-CAB

Model
3557

LAB-LINE INSTRUMENTS, Inc.

Designers and Manufacturers
Lab-Line Plaza
Melrose Park, Illinois 60160
U.S.A.

Phone: (312) 450-2600 Telex: 6871028LBLIN UW

WARRANTY

LAB-LINE INSTRUMENTS, Inc., for itself and all of its subsidiaries ("Lab-Line"), does hereby warrant for a period of 15 months from the date of receipt by the User, under normal and proper usage, all of its products (except P.A.C.E. anaerobic chambers) against defects in workmanship and material, and will repair or replace any defective part(s) without charge when same is shipped prepaid to the authorized Lab-Line distributor from which the product was originally purchased. P.A.C.E. anaerobic chambers are warranted for a period of 12 months, except the vinyl front panel and rubber sleeves/ gloves which are warranted for 30 days, from the date of receipt by the User.

Should the nature of any defect require that the product or any constituent portion thereof be returned by such authorized distributor to Lab-Line's factory at Melrose Park, Illinois, prepaid, for service, a condition precedent to any return shall be the procurement by such dealer of written authorization from Lab-Line assigning a Return Goods Number to the product or part requiring service.

Parts and accessories manufactured by others are warranted only to the extent of the regular warranty of the manufacturer or supplier of such materials and only insofar as Lab-Line is able to transfer the benefits of warranty coverage, if any, to the User. Any adequately warranted defective part or accessory manufactured or supplied by others may be exchanged through an authorized Lab-Line dealer for a replacement part, and no charge in respect thereof shall be assessed if the defective part is shipped prepaid and received at Lab-Line's factory within 30 days from the date any replacement part is obtained by the User.

This warranty supersedes and is given in lieu of all implied warranties, and is void if the User does not provide the unit with continuous ample electrical power at constant voltage, consistent with the specifications of the product.

With respect to all Explosion-Proof and Flammable Material Storage (FMS) Refrigerators and Freezers, storage by User of any materials in the product which may cause deterioration of any components of the product shall be deemed to constitute abnormal and improper usage for the purposes of this warranty.

TO OBTAIN THE BENEFITS CONFERRED BY THIS WARRANTY, USER MUST RETURN THE WARRANTY CARD TO LAB-LINE WITHIN SEVEN (7) BUSINESS DAYS AFTER RECEIPT OF THE PRODUCT.

LAB-LINE INSTRUMENTS, Inc.
(and all of its subsidiaries)

We are pleased with your choice of LAB-LINE INSTRUMENTS for your equipment needs. For maximum value and ease of start-up, please proceed as follows:

1. Inspect the carton and the unit for shipping damage. Notify the carrier immediately if damage is found.
2. Use the "Accessory Check List" when unpacking to verify that the complete unit has been received.
3. Read this operation manual thoroughly before deciding on an appropriate location for the unit. You must consider the availability of power and/or gas hook-ups, drains and other unit requirements as well as user convenience in operation.
4. Carefully follow directions in the "Installation" section of this manual.
5. Insist that each operator of the unit is familiar with the "Operation" section of this manual.
6. Keep this manual in a safe location for ready reference to the "Operation" and "Maintenance" sections when needed.
7. If, after reading this manual, you have any difficulty installing, operating or maintaining this equipment, please call:

LAB-LINE CUSTOMER RELATIONS DEPARTMENT
800-323-0257 (outside Illinois)
312-450-2600 (inside Illinois)

8. Don't forget to fill out anti mail in the warranty card to:

LAB-LINE INSTRUMENTS, INC.
Lab-Line Plaza, Melrose Park, IL 60160 U.S.A.

ALL RIGHTS RESERVED

The information contained in this manual is the exclusive property of Lab-Line Instruments, Inc., and has been provided solely to enable the users of the equipment described herein to operate and maintain such equipment. Any other use of this information, or the reproduction or transmission of all or any portion of this manual, without prior written consent of LAB-LINE INSTRUMENTS, INC. is expressly prohibited.

INSTALLATION

1. UNPACKING

Examine shipping carton and contents for damage. If any damage is found, call carrier immediately and file a claim.

Unpack the unit carefully. Do not discard packing materials until all parts are accounted for.

2. LOCATION

Select a convenient location that is away from direct sunlight and free of drafts, strong air currents, other heat sources, and extraneous vibrations. The unit will be installed as stationary equipment.

3. CLEARANCE

Allow sufficient clearance at rear of unit so personnel can gain access when maintenance is required. Once installed, the unit is not easily moved.

4. VENTILATION

When unit is installed under a counter, provision should be made for air circulation or venting at the rear and out the top rear of the refrigerator over the finned condenser. A grille covered opening of not less than 3" x 18" should be provided in the counter top for venting. DO NOT back the unit up to heat ducts or hot water lines. Where adequate ventilation is provided at the rear of the cabinet, the counter vent will not be necessary.

5. ELECTRICAL CONNECTION

Connect the unit to a properly fused and grounded branch circuit with the same electrical characteristics as marked on the nameplate. Installation of electrical wiring and equipment must be made in an approved manner, by a qualified electrician with experience in explosion-proof wiring for use in Hazardous Locations Class I, Groups C and D. Reference Chapter 5, Articles 500 and 501 of the National Electrical Code.

Use Underwriters' Laboratories labeled threaded metal conduit and fittings. DO NOT connect through a flexible cord, attachment plug and receptacle. Customer must provide and install an explosion-proof disconnect switch. Switch must be connected directly to the two wire leads provided at the rear of the unit.

OPERATION

NOTICE: This unit is **NOT** designed for storage of corrosive materials. The interior of this unit can be seriously damaged by storing corrosives inside.

Use of this unit to store corrosive materials, or operation in corrosive environments, voids the warranty.

1. Move power switch to ON position
2. The chamber temperature is designed to maintain an average cabinet temperature of 40 degrees F. Allow unit to attain thermal equilibrium before making temperature adjustments.
3. To adjust the thermostat for slightly colder temperatures:
 - A. Switch OFF power.
 - B. Remove grille and open explosion-proof box containing thermostat.
 - C. Turn thermostat knob clockwise for colder temperatures.
 - D. Close explosion-proof box and replace grille. **DO NOT** operate the unit with explosion-proof box open.
 - E. Switch power ON.

MAINTENANCE

* Make no attempt to service or repair a Lab-Line product *
 * under warranty before consulting your Lab-Line dealer. *
 * After the warranty period, such-consultation is still *
 * advised, especially when the repair may be technically *
 * sophisticated or difficult. *
 *

* If assistance is needed beyond what the distributor can *
 * provide, please call the Lab-Line Customer Relations *
 * Department at 312-450-2600. *
 *

* No merchandise, however, should be returned directly to *
 * Lab-Line without approval. *

1. DEFROSTING

Defrost the unit when frost builds up to 1/4" thick.

- A. Remove temperature-sensitive materials from the refrigerator.
- B. Turn OFF the cold control (fully counterclockwise) in the explosion-proof box behind the grille or switch off power to the unit.
- C. Place pans of hot water inside freezer compartment to hasten the melting. Leave the door open. DO NOT use any, type of electric defroster.
- D. Remove drain plug from inside bottom of freezer. Remove exterior base grille. Unclip the drain hose and allow defrost water to drain through the hose into a flat pan.
- E. After defrosting and cleaning, hook drain hose in place, reset cold control and close explosion-proof box, then replace grille.

2. ROUTINE CLEANING

Wash the interior, exterior, door liner and gasket with warm water and mild soap or detergent. Rinse thoroughly and dry.

DO NOT USE cleaning waxes, concentrated detergents, bleaches and cleansers containing petroleum products to clean the door gasket or plastic parts. Do not use abrasive or harsh cleansers on any part of the unit.

Keep the condenser free of dust and lint for maximum cooling efficiency. The condenser is located on the back of the unit.

3. SERVICING AND REPAIRS

Before calling a serviceman, check the following:

- A. Be sure the power switch and temperature control are in ON position.
- B. Be sure condenser on back of unit is clean.
- C. If there is a rattling or jingling noise, look for something on top, at bottom, or behind unit which vibrates when motor is running.

Refrigeration and electrical repairs must be performed by service personnel with experience on explosion-proof equipment located in Hazardous Locations, Class I, Groups C and D.

DO NOT LUBRICATE ANY PART OF THE UNIT.

SERVICE GUIDES

Refrigeration and electrical repairs must be performed by service personnel with experience on explosion-proof equipment located in Hazardous Locations, Class I, Groups C and D.

1. COMPRESSOR REPLACEMENT

- A. Disconnect power from unit before servicing.
- B. Loosen union at compressor enclosure and disconnect three wire leads.
- C. Pierce the HI and LOW tubes leading to the condenser and let gas escape.
- D. Cut these tubes.
- E. Remove four mounting screws and remove compressor.
- F. Mount new compressor with screws.
- G. Resolder tubes, evacuate system, then recharge with refrigerant R-12 (7.5 ounces).
- H. Reconnect leads according to wiring diagram then tighten union at compressor enclosure.

2. THERMOSTAT REPLACEMENT

- A. Disconnect power to unit before servicing.
- B. Loosen temperature-sensing bulb inside chamber.
- C. Remove grille at lower front, remove the four screws from explosion-proof box containing the thermostat.
- D. Open box and pull off cold control dial. Remove thermostat.
- E. Install replacement thermostat in reverse order. Be sure not to bend the capillary tubing to a radius of less than 1/2".
- F. Replace explosion-proof box cover and grille.

TYPE "D"
SERVICE REPLACEMENT COMPRESSOR

642952 (1 060 BTU -2750 RPM 1220V 60 HZ - OIL CHG 10 1/4 OZ)

DISCHARGE RETURN TUBE (PRECOOLER)
5/16" OD X .028 WALL - STEEL

2ND DISCHARGE TUBE (CONDENSER)
5/16" OD X .028 WALL - STEEL

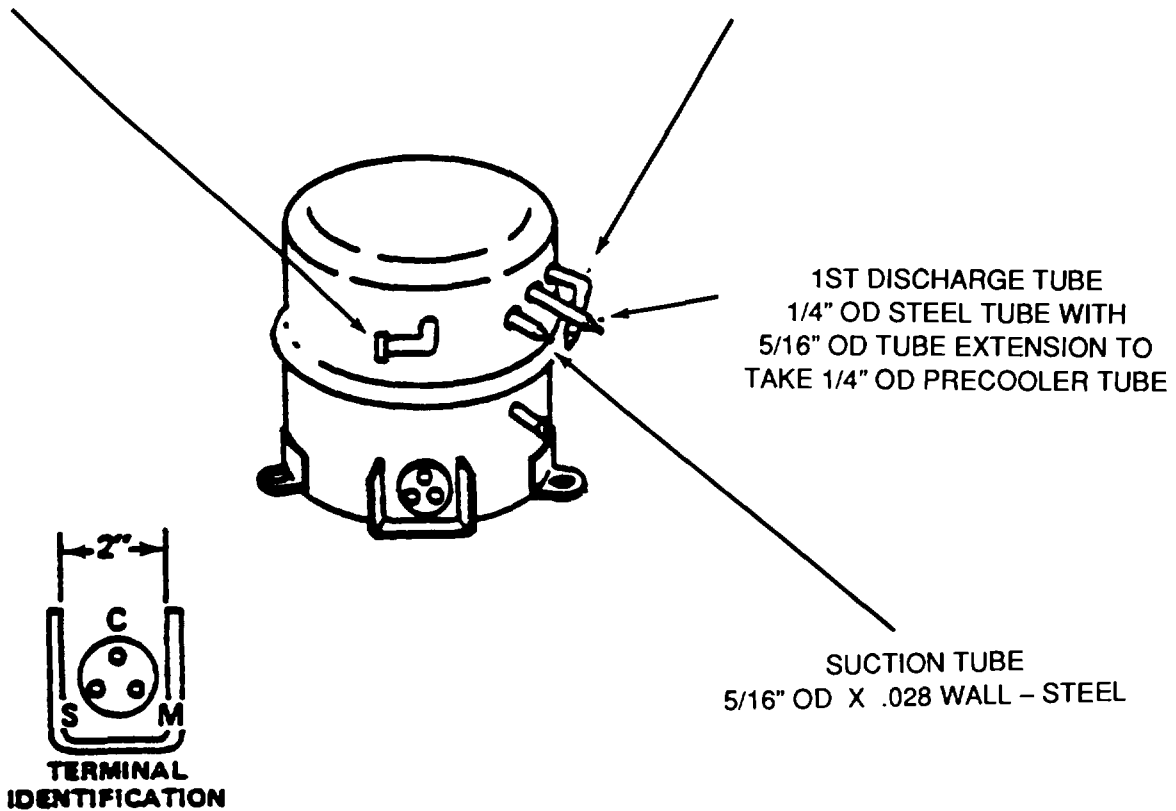

NOTE: THE FIRST DISCHARGE AND DISCHARGE RETURN STUBS MUST BE CONNECTED TO PRECOOLER. THE SECOND DISCHARGE STUB MUST BE CONNECTED TO CONDENSER.

CAUTION: NOTE ELECTRICAL TERMINAL ARRANGEMENT. INCORRECT CONNECTIONS MAY RESULT IN BURNT MOTOR WINDINGS.

DESCRIPTION	REPLACEMENT PARTS	PART NUMBER
COMPRESSOR		42240508
EVAPORATOR		42240628
RELAY		41001566
THERMOSTAT		42240592
WIRING DIAGRAM		2-227-210-00

APPENDIX A
REFERENCES

A-1. **Scope.** This appendix contains all forms, pamphlets and technical manuals referenced in both the Air mobile and Semitrailer mounted Laboratories.

A-2. **Forms.**

Recommended Changes to Publications	DA Form 2028
	DA Form 2028-2
Quality Deficiency Report	SF 368
Equipment Inspection and Maintenance Work Sheet	DA Form 2404
Hand Receipts	DA Form 2062

A-3. **Field Manuals.**

Petroleum Testing Facilities:

Laboratories and Kits	FM 10-72
Inspecting and Testing Petroleum Products	FM 10-70
ASTM Test Method Supplement to.. ..	FM10-92C1/C2

A-4. **Technical Manuals.**

Atlas-Copco Compressor	TM 10-4310-392-13&P
Alcor Jet Fuel Thermal Oxidation Tester Operating and Maintenance Manual	TM 10-6635-210-13&P
Bacharach Gas Alarm and Calibration Data	TM 10-6665-297-13&P
Brother Portable Typewriter	TM 10-7430-218-13&P
Chemtrix Field Ph Meter	TM 10-6630-237-13&P
Elkay Manufacturing 30 GPH Cooler	TM 10-4130-240-13&P
Emcee Micro-Separometer	TM 10-6640-222-13&P
Foxboro Pressure Recording Gauge	TM 10-6685-365-13&P
Gammon Aqua Glo Water Detector	TM 10-6640-221-13&P
Gammon Mini Monitor Fuel Sampling Kit	TM 10-6630-230-13&P
Jelrus Burn-Out Furnace	TM 10-6640-231-13&P
Koehler Cleveland Open Tester	TM 10-6630-236-13&P
Koehler Cloud and Pour Point Chamber	TM 10-6630-238-13&P
Koehler Copper Strip Corrosion Bomb Bath	TM 10-6640-220-1 3&P
Koehler Distillation Apparatus	TM 10-6630-233-13&P
Koehler Dropping Point Apparatus	TM 10-6635-211-13&P
Koehler Electric Pensky-Martins Tester	TM 10-6630-231-13&P
Koehler Foaming Characteristics Determination Apparatus	TM 10-6640-228-13&P
Koehler Kinematic Viscosity Bath	TM 10-6630-239-13&P
Koehler Tag Closed Cup Flash Tester	TM 10-6630-235-13&P
Lab-Line Explosion Proof Refrigerator	TM 10-6640-219-13&P
Lily Freezer	TM 10-6640-234-13&P
Millipore OM39 Filter Holder	TM 10-6640-225-13&P
Millipore Vacuum Pump	TM 10-6640-217-13&P
Ohaus Harvard Trip Balance	TM 10-6670-278-13&P
Precision Gas-Oil Distillation Test Equipment	TM 10-43630-219-13&P
Precision General Purpose Water Bath	TM 10-6640-229-13&P

TM 10-6640-219-13&P

Precision High Temperature Bronze Block Gum Bath	TM 10-6630-234-13&P
Precision General Purpose Ovens	TM 10-6640-218-13&P
Precision Heater Instruction Manual and Parts List	TM 10-6640-223-13&P
Precision Oxidation Stability Bath	TM 10-6640-232-13&P
Precision Pensky–Martens Flash Testers	TM 10-6630-231–13&P
Precision Reid Vapor Pressure Bath	TM 10-6640-226-13&P
Precision Slo-Speed Stirrer	TM 10-6640-224-13&P
Precision Universal Centrifuge	TM 10-6640-230-13&P
Precision Universal Penetrometer	TM 10-6640-228-13&P
Sargent–Welch Vacuum Pump	TM 10-4310-391-13&P
Sartorius Analytical Balance	TM 10-6670-277-13&P
Scotsman Cuber	TM 10-6640-227-13&P
Soltec VOM-Multimeter	TM 10-6625-3127-13&P
Teel Self–Priming Centrifugal Pump	TM 10-6640-217–13&P
Teel Submersible Pump	TM 10-4320-320-13&P
Texas Instrument TI–5030II Calculator	TM 10-7420-210-13&P

A–5. Pamphlets.

The Army Maintenance Management System (TAMMS)	DA Pam738-750
--	---------------

A-6. Miscellaneous Publications.

The Army Integrated Publishing and Printing Program	AR 25-30
Laboratory Airmobile, Aviation Fuel	MIL–L-52733A(ME)
Apparatus, Instruments, Chemicals, Furniture, and Supplies for Industrial, Clinical, College and Government Laboratories	Fisher Scientific Laboratories Catalog
Petroleum–Petrochemical Testing Equipment	Precision Scientific Catalog

APPENDIX B

MAINTENANCE ALLOCATION CHART

Section L INTRODUCTION

B-1. **General.**

a. This section provides a general explanation of all maintenance and repair functions authorized at various maintenance categories.

b. The Maintenance Allocation Chart (MAC) in Section II designates overall authority and responsibility for the performance of maintenance functions on the identified end item or component. The application of the maintenance functions to the end item or component will be consistent with the capacities and capabilities of the designated maintenance categories.

c. Section III lists the tools and test equipment (both special tools and common tool sets) required for each maintenance function as referenced from Section II.

d. Section IV contains supplemental instructions and explanatory notes for a particular maintenance function.

B-2. Maintenance Functions. Maintenance functions will be limited to and defined as follows:

a. **Inspect.** To determine the serviceability of an item by comparing its physical, mechanical, and/or electrical characteristics with established standards through examination (e.g., by sight, sound, or feel).

b. **Test.** To verify serviceability by measuring the mechanical, pneumatic, hydraulic, or electrical characteristics of an item and comparing those characteristics with prescribed standards.

c. **Service.** Operations required periodically to keep an item in proper operating condition, i.e., to clean (includes decontaminate, when required), to preserve, to drain, to paint, or to replenish fuel, lubricants, chemical fluids, or gases.

d. **Adjust.** To maintain or regulate, within prescribed limits, by bringing into proper or exact position, or by setting the operating characteristics to specified parameters.

e. **Align.** To adjust specified variable elements of an item to bring about optimum or desired performance.

f. **Calibrate.** To determine and cause corrections to be made or to be adjusted on instruments or test, measuring, and diagnostic equipments used in precision measurement. Consists of comparisons of two instruments, one of which is a certified standard of knob accuracy, to detect and adjust any discrepancy in the accuracy of the instrument being compared.

g. **Rernove/Install** To remove and install the same item when required to perform service or other maintenance functions. Install may be the act of emplacing, seating, or fixing into position a spare, repair part, or module (component or assembly) in a manner to allow the proper functioning of an equipment or system.

h. **Replace.** To remove an unserviceable item and install a serviceable counterpart in its place. "Replace" is authorized by the MAC and is shown as the third position code of the SMR code.

i. Repair. The application of maintenance services, including fault location/troubleshooting,² removal/installation, and disassembly/assembly procedures,³ and maintenance actions,⁴ to identify troubles and restore serviceability to an item by correcting specific damage, fault, malfunction, or failure in a part, subassembly, module (component or assembly), end item, or system.

j. Overhaul. That maintenance effort (service/action) prescribed to restore an item to a Completely serviceable/operational condition as required by maintenance standards in appropriate technical publications (i.e., DMWR). Overhaul is normally the highest degree of maintenance performed by the Army. Overhaul does not normally return an item to like-new condition.

k. Rebuild. Consists of those services/actions necessary for the restoration of unserviceable equipment to a like-new condition in accordance with original manufacturing standards. Rebuild is the highest degree of materiel maintenance applied to Army equipment. The rebuild operation includes the act of returning to zero those age measurements (hours/miles, etc.) considered in classifying Army equipment/components.

B-3. Explanation Of Columns In The MAC, Section II

a. Column 1. Group Number. Column 1 lists functional group code numbers, the purpose of which is to identify maintenance significant components, assemblies, subassemblies, and modules with the next higher assembly. End item group number shall be "00."

b. Column 2. Component/Assembly. Column 2 contains the names of components, assemblies, subassemblies, and modules for which maintenance is authorized.

c. Column 3. Maintenance Function. Column 3 lists the functions to be performed on the item listed in column 2. (For a detailed explanation of these functions, see paragraph B-2.)

d. Column 4. Maintenance Category. Column 4 specifies, by the listing of a work time figure in the appropriate subcolumn(s), the category of maintenance authorized to perform the function listed in column 3. This figure represents the active time required to perform that maintenance function at the indicated category of maintenance. If the number or complexity of the tasks within the listed maintenance function vary at different maintenance categories, appropriate work time figures will be shown for each category. The work time figure represents the average time required to restore an item (assembly, subassembly, component, module, end item, or system) to a serviceable condition under typical field operating conditions. This time includes preparation time (including any necessary disassembly/assembly time), troubleshooting/fault location time, and quality assurance/quality control time in addition to the time required to perform the specific tasks identified for the maintenance functions authorized in the maintenance allocation chart. The symbol designations for the various maintenance categories are as follows:

¹ Services – inspect, test, service, adjust, align, calibrate, and/or replace.

²Fault locate/troubleshoot – the process of investigating and detecting the cause of equipment malfunctioning; the act of isolating a fault within a system or unit under test (UUT).

³Disassemble/assemble- encompasses the step-by-step taking apart (or breakdown) of a spare/functional group coded item to the level of its least component identified as maintenance significant (i. e., assigned an SMR code) for the category of maintenance under consideration.

⁴Actions_ welding, grinding, riveting, straightening, facing, remachining, and/or resurfacing.

- c Operator/Crew
- O* Unit Maintenance
- F Direct Support Maintenance
- H General Support Maintenance
- D Depot Maintenance

e. **Column 5. Tools and Equipment.** Column 5 specifies, by code, those common tool sets (not individual tools) and special tools, TMDE, and support equipment required to perform the designated function.

f. **Column 6. Remarks.** This column shall, when applicable, contain a letter code, in alphabetic order, which shall be keyed to the remarks contained in section IV.

B-4. Explanation Of Columns In Tool And Test Equipment Requirements, Section III.

a. **Column 1. Reference Code.** The tool and test equipment reference code correlates with a code used in the MAC, section II, column 5.

b. **Column 2. Maintenance Category.** The lowest category of maintenance authorized to use the tool or test equipment.

c. **Column 3. Nomenclature.** Name or identification of the tool or test equipment.

d. **Column 4. National Stock Number.** The National stock number of the tool or test equipment.

e. **Column 5. Tool Number.** The manufacturer's part number.

B-5. Explanation of Columns In Remarks, Section IV.

a. **Column 1. Reference Code.** The code recorded in column 6, Section 11.

b. **Column 2. Remarks.** This column lists information pertinent to the maintenance function being performed as indicated in the MAC, section II.

Section II. MAINTENANCE ALLOCATION CHART

(1) GROUP NUMBER	(2) COMPONENT/ ASSEMBLY	(3) MAINTENANCE FUNCTION	(4) MAINTENANCE LEVEL					(5) TOOLS AND EQUIPMENT	(6) REMARKS
			UNIT		DS	GS	DEPOT		
			C	O	F	H	D		
01	EXPLOSION PROOF REFRIGERATOR	INSPECT REPLACE REPAIR	0.1	0.5	4.0			1 1, 2, 3	

SECTION III. TOOL AND TEST EQUIPMENT REQUIREMENTS
FOR
MAINTENANCE ALLOCATION CHART

(1) TOOL/TEST EQUIP. REF CODE	(2) MAINTENANCE CATEGORY	(3) NOMENCLATURE	(4) NSN	(5) TOOL NUMBER
1	O, F	TOOL KIT, GENERAL AUTOMOTIVE	5180-00-177-7033	(50980) SC5180-90- CL-N26
2	O, F	KIT, SOLDERING GUN, 115V, 60 CYCLE COMPLETE WITH SOLDER AND CASE	3439-00-618-6623	
3	O, F	SHOP EQUIPMENT, AUTOMOTIVE MAINTENANCE & REPAIR: COMMON #1 (LESS POWER)	4910-00-754-0654	(19204) SC 4910-95- CL-A74

SECTION IV. REMARKS

NOT APPLICABLE

APPENDIX C
COMPONENTS OF END ITEM AND BASIC ISSUE ITEMS LISTS
NOT APPLICABLE

APPENDIX D
ADDITIONAL AUTHORIZATION LIST
NOT APPLICABLE

APPENDIX E
EXPENDABLE/DURABLE SUPPLIES AND MATERIALS LIST
NOT APPLICABLE

By Order of the Secretary of the Army:

CARL E. VUONO
General, United States Army
Chief of Staff

Official:

THOMAS F. SIKORA
Brigadier General, United States Army
The Adjutant General

DISTRIBUTION:

To be distributed in accordance with DA Form 12-21 A, Operator, Unit and Direct Support Maintenance requirements for Laboratory, Air Mobile, Aviation Fuel and Laboratory, Petroleum, MTD

* U.S. GOVERNMENT PRINTING OFFICE: 1991 554-123/20140

RECOMMENDED CHANGES TO EQUIPMENT TECHNICAL PUBLICATIONS



THEN... JOT DOWN THE DOPE ABOUT IT ON THIS FORM, CAREFULLY TEAR IT OUT, FOLD IT AND DROP IT IN THE MAIL!

SOMETHING WRONG WITH THIS PUBLICATION?

FROM: (PRINT YOUR UNIT'S COMPLETE ADDRESS)

PFC JOHN DOE
COA, 3d ENGINEER BN
FT. LEONARDWOOD, MD 63108

DATE SENT

PUBLICATION NUMBER

TM 10-6640-219-13&P

PUBLICATION DATE

28 Sep 90

PUBLICATION TITLE

Labline Explosion
Proof Refrigerator (Model 3557)

BE EXACT PIN-POINT WHERE IT IS

PAGE NO	PARA-GRAPH	FIGURE NO	TABLE NO
6	2-1 a		
B1		4-3	
125	line 20		

IN THIS SPACE TELL WHAT IS WRONG AND WHAT SHOULD BE DONE ABOUT IT:

In line 6 of paragraph 2-1a the manual states the engine has 6 cylinders. The engine on my set only has 4 cylinders. Change the manual to show 4 cylinders.

Callout 16 on figure 4-3 is pointing at a bolt. In key to figure 4-3, item 16 is called a shim - Please correct one or the other.

I ordered a gasket, item 19 on figure B-16 by NSN 2 910-00-762-3001. I got a gasket but it doesn't fit. Supply says I got what I ordered, so the NSN is wrong. Please give me a good NSN

PRINTED NAME, GRADE OR TITLE, AND TELEPHONE NUMBER

JOHN DOE, PFC (268) 317-7111

SIGN HERE

JOHN DOE

DA FORM 2028-2
1 JUL 79

PREVIOUS EDITIONS ARE OBSOLETE.
DRSTS-M Overprint 1, 1 Nov 80

PS --IF YOUR OUTFIT WANTS TO KNOW ABOUT YOUR RECOMMENDATION MAKE A CARBON COPY OF THIS AND GIVE IT TO YOUR HEADQUARTERS

TEAR ALONG PERFORATED LINE

FILL IN YOUR
UNIT'S ADDRESS



FOLD BACK

DEPARTMENT OF THE ARMY

OFFICIAL BUSINESS

COMMANDER
U.S. ARMY TROOP SUPPORT COMMAND
ATTN: AMSTR-MCTS
4300 GOODFELLOW BOULEVARD
ST. LOUIS, MO 63120-1798

TEAR ALONG PERFORATED LINE

FILL IN YOUR
UNIT'S ADDRESS



FOLD BACK

DEPARTMENT OF THE ARMY

OFFICIAL BUSINESS

COMMANDER
U.S. ARMY TROOP SUPPORT COMMAND
ATTN: AMSTR-MCTS
4300 GOODFELLOW BOULEVARD
ST. LOUIS, MO 63120-1798

TEAR ALONG PERFORATED LINE

RECOMMENDED CHANGES TO EQUIPMENT TECHNICAL PUBLICATIONS



THEN... JOT DOWN THE DOPE ABOUT IT ON THIS FORM. CAREFULLY TEAR IT OUT. FOLD IT AND DROP IT IN THE MAIL!

SOMETHING WRONG WITH THIS PUBLICATION?

FROM: (PRINT YOUR UNIT'S COMPLETE ADDRESS)

DATE SENT

PUBLICATION NUMBER

TM 10-6640-219-13&P

PUBLICATION DATE

28 Sep 90

PUBLICATION TITLE

Labline Explosion Proof Refrigerator (Model 3557)

BE EXACT. PIN-POINT WHERE IT IS

PAGE NO	PARA-GRAPH	FIGURE NO	TABLE NO

IN THIS SPACE TELL WHAT IS WRONG AND WHAT SHOULD BE DONE ABOUT IT:

TEAR ALONG PERFORATED LINE

PRINTED NAME, GRADE OR TITLE, AND TELEPHONE NUMBER

SIGN HERE:

DA FORM 2028-2
1 JUL 79

PREVIOUS EDITIONS ARE OBSOLETE.
DRSTS-M Overprint 2, 1 Nov 80.

P.S.--IF YOUR OUTFIT WANTS TO KNOW ABOUT YOUR RECOMMENDATION MAKE A CARBON COPY OF THIS AND GIVE IT TO YOUR HEADQUARTERS.

FILL IN YOUR
UNIT'S ADDRESS.



FOLD BACK

DEPARTMENT OF THE ARMY

OFFICIAL BUSINESS

COMMANDER
U.S. ARMY TROOP SUPPORT COMMAND
ATTN: AMSTR-MCTS
4300 GOODFELLOW BOULEVARD
ST. LOUIS, MO 63120-1798

TEAR ALONG PERFORATED LINE

RECOMMENDED CHANGES TO EQUIPMENT TECHNICAL PUBLICATIONS



THEN... JOT DOWN THE DOPE ABOUT IT ON THIS FORM. CAREFULLY TEAR IT OUT. FOLD IT AND DROP IT IN THE MAIL!

SOMETHING WRONG WITH THIS PUBLICATION?

FROM: (PRINT YOUR UNIT'S COMPLETE ADDRESS)

DATE SENT

PUBLICATION NUMBER
TM 10-6640-219-13&P

PUBLICATION DATE
28 Sep 90

PUBLICATION TITLE
Labline Explosion
Proof Refrigerator (Model 3557)

BE EXACT. PIN-POINT WHERE IT IS

PAGE NO	PARA-GRAPH	FIGURE NO	TABLE NO
---------	------------	-----------	----------

IN THIS SPACE TELL WHAT IS WRONG AND WHAT SHOULD BE DONE ABOUT IT:

TEAR ALONG PERFORATED LINE

PRINTED NAME, GRADE OR TITLE, AND TELEPHONE NUMBER

SIGN HERE

DA FORM 1 JUL 79 2028-2

PREVIOUS EDITIONS ARE OBSOLETE.
DRSTS-M Overprint 2, 1 Nov 80.

P.S.--IF YOUR OUTFIT WANTS TO KNOW ABOUT YOUR RECOMMENDATION MAKE A CARBON COPY OF THIS AND GIVE IT TO YOUR HEADQUARTERS.

FILL IN YOUR
UNIT'S ADDRESS.



FOLD BACK

DEPARTMENT OF THE ARMY

OFFICIAL BUSINESS

COMMANDER
U.S. ARMY TROOP SUPPORT COMMAND
ATTN: AMSTR-MCTS
4300 GOODFELLOW BOULEVARD
ST. LOUIS, MO 63120-1798

TEAR ALONG PERFORATED LINE

The Metric System and Equivalents

Linear Measure

1 centimeter = 10 millimeters = .39 inch
 1 decimeter = 10 centimeters = 3.94 inches
 1 meter = 10 decimeters = 39.37 inches
 1 dekameter = 10 meters = 32.8 feet
 1 hectometer = 10 dekameters = 328.08 feet
 1 kilometer = 10 hectometers = 3,280.8 feet

Weights

1 centigram = 10 milligrams = .15 grain
 1 decigram = 10 centigrams = 1.54 grains
 1 gram = 10 decigram = .035 ounce
 1 dekagram = 10 grams = .35 ounce
 1 hectogram = 10 dekagrams = 3.52 ounces
 1 kilogram = 10 hectograms = 2.2 pounds
 1 quintal = 100 kilograms = 220.46 pounds
 1 metric ton = 10 quintals = 1.1 short tons

Liquid Measure

1 centiliter = 10 milliliters = .34 fl. ounce
 1 deciliter = 10 centiliters = 3.38 fl. ounces
 1 liter = 10 deciliters = 33.81 fl. ounces
 1 dekaliter = 10 liters = 2.64 gallons
 1 hectoliter = 10 dekaliters = 26.42 gallons
 1 kiloliter = 10 hectoliters = 264.18 gallons

Square Measure

1 sq. centimeter = 100 sq. millimeters = .155 sq. inch
 1 sq. decimeter = 100 sq. centimeters = 15.5 sq. inches
 1 sq. meter (centare) = 100 sq. decimeters = 10.76 sq. feet
 1 sq. dekameter (are) = 100 sq. meters = 1,076.4 sq. feet
 1 sq. hectometer (hectare) = 100 sq. dekameters = 2.47 acres
 1 sq. kilometer = 100 sq. hectometers = .386 sq. mile

Cubic Measure

1 cu. centimeter = 1000 cu. millimeters = .06 cu. inch
 1 cu. decimeter = 1000 cu. centimeters = 61.02 cu. inches
 1 cu. meter = 1000 cu. decimeters = 35.31 cu. feet

Approximate Conversion Factors

To change	To	Multiply by	To change	To	Multiply by
inches	centimeters	2.540	ounce-inches	newton-meters	.007062
feet	meters	.305	centimeters	inches	.394
yards	meters	.914	meters	feet	3.280
miles	kilometers	1.609	meters	yards	1.094
square inches	square centimeters	6.451	kilometers	miles	.621
square feet	square meters	.093	square centimeters	square inches	.155
square yards	square meters	.836	square meters	square feet	10.764
square miles	square kilometers	2.590	square meters	square yards	1.196
acres	square hectometers	.405	square kilometers	square miles	.386
cubic feet	cubic meters	.028	square hectometers	acres	2.471
cubic yards	cubic meters	.765	cubic meters	cubic feet	35.315
fluid ounces	milliliters	29.573	cubic meters	cubic yards	1.308
pints	liters	.473	milliliters	fluid ounces	.034
quarts	liters	.946	liters	pints	2.113
gallons	liters	3.785	liters	quarts	1.057
ounces	grams	28.349	liters	gallons	.264
pounds	kilograms	.454	grams	ounces	.035
short tons	metric tons	.907	kilograms	pounds	2.205
pound-feet	newton-meters	1.356	metric tons	short tons	1.102
pound-inches	newton-meters	.11296			

Temperature (Exact)

°F	Fahrenheit	5/9 (after	Celsius	°C
	temperature	subtracting 32)	temperature	

This fine document...

Was brought to you by me:



[Liberated Manuals -- free army and government manuals](#)

Why do I do it? I am tired of sleazy CD-ROM sellers, who take publicly available information, slap “watermarks” and other junk on it, and sell it. Those masters of search engine manipulation make sure that their sites that sell free information, come up first in search engines. They did not create it... They did not even scan it... Why should they get your money? Why are not letting you give those free manuals to your friends?

I am setting this document FREE. This document was made by the US Government and is NOT protected by Copyright. Feel free to share, republish, sell and so on.

I am not asking you for donations, fees or handouts. If you can, please provide a link to liberatedmanuals.com, so that free manuals come up first in search engines:

<A HREF=<http://www.liberatedmanuals.com/>>Free Military and Government Manuals

- Sincerely
Igor Chudov
<http://igor.chudov.com/>
- [Chicago Machinery Movers](#)