

TECHNICAL MANUAL

**OPERATOR'S, UNIT AND
DIRECT SUPPORT MAINTENANCE MANUAL
(INCLUDING REPAIR PARTS AND SPECIAL TOOLS LIST)
FOR**

**PRECISION HIGH TEMPERATURE BRONZE
BLOCK GUM BATH**

MODEL TS-74801-AR-3

NSN 6630-00-895-1259

This technical manual is an authentication of the manufacturer's commercial literature and does not conform with the format and the content requirements normally associated with Army technical manuals. This technical manual does, however, contain all essential information required to operate and maintain the equipment.

Approved for public release; distribution is unlimited.

**HEADQUARTERS, DEPARTMENT OF THE ARMY
28 SEPTEMBER 1990**

This technical manual is an authentication of the manufacturer's commercial literature and does not conform with the format and the content requirements normally associated with Army technical manuals. This technical manual does, however, contain all essential information required to operate and maintain the equipment.

Approved for public release; distribution is unlimited.

SUPPLEMENTARY INTRODUCTORY MATERIAL

1-1. Maintenance Forms and Records.

Department of the Army forms and procedures used for equipment maintenance will be those described by DA Pam 738-750, The Army Maintenance Management System.

1-2. Reporting Errors and Recommending Improvements.

You can help improve this manual. If you find any mistakes or if you know of a way to improve the procedures, please let us know. Mail your letters, DA Form 2028 (Recommended Changes to Publications and Blank Forms), or DA Form 2028-2 located in the back of this manual, directly to: Commander, U.S. Army Troop Support Command, ATTN: AMSTR-MCTS, 4300 Goodfellow Blvd., St. Louis, MO 63120-1798. A reply will be furnished to you.

1-3. Destruction of Army Material to Prevent Enemy Use.

Refer to TM 750-244-3 for instructions covering the destruction of Army Material to prevent enemy use.

1-4. Administrative Storage of Equipment.

a. Placement of equipment in administrative storage should be for short periods of time when a shortage of maintenance effort exists. Items should be in mission readiness within 24 hours or within the time factors as determined by the directing authority. During the storage period appropriate maintenance records will be kept.

b. Before placing equipment in administrative storage, current preventive maintenance checks and services should be completed. Shortcomings and deficiencies should be corrected, and all modification work orders (MWO's) should be applied.

c. Storage site selection. Inside storage is preferred for items selected for administrative storage. If inside storage is not available, trucks, vans, conex containers and other containers may be used.



GCA CORPORATION
Instruments and Equipment Group
3737 West Cortland Street
Chicago, Illinois 60647
Telephone: 312-227-2660
Telex: 4330120 (ITT)
254028 (WUT)

ADDENDUM TO: INSTRUCTION MANUAL, TS 74801 AR-3, HIGH TEMPERATURE BRONZE BLOCK GUM BATH

The Temperature Controller/Indicator, catalog no. 74802, (accessory for catalog no. 74801) has been redesigned and can be employed with both older and the current versions of the High Temperature Bronze Block Gum Bath.

The recently designed Controller (Digital Type) can be identified by the catalog no. 74802 and the serial number prefixed with the number 11 or higher.

Example: SN 11 AS 6

This controller requires a type "J" thermocouple.

Along with the above change the High Temperature Bronze Block Gum Bath, catalog no. 74801, has been modified to accept this Controller and contains a serial number prefixed with the number 11 or higher.

Example: SN 11 AS 6

Installation Requirements

1. The High Temperature Bronze Block Gum Bath (catalog no. 74801) with a serial number of 11 or higher, and a Controller with a serial number of 11 or higher requires electrical connections per the attached wiring diagrams.

CAUTION: Do Not substitute a different controller.

2. If the Bronze Block Gum Bath (catalog no. 74801) contains the serial number prefixed with the number 10 the Temperature Controller/Indicator (Analog-Type) catalog no. 74802, containing a serial number prefixed with the number 10, may be employed.

This controller requires a type "E" thermocouple.

Use the wiring diagram shown in TS-74801 AR-3, instruction manual for proper connections.

3. If the Bronze Block Gum Bath (catalog no. 74801) contains the serial number prefixed with the number 10, and the new Temperature Controller/Indicator (Digital Type) catalog no. 74802 containing a serial number prefixed with the number 11, may be employed after completing the following modifications;
 - a. Drill a 15/16" dia. hole and install #215203 cable connector. See attached drawing, BOTTOM VIEW, SERIAL NUMBER 11 OR HIGHER, for approximate location.
 - b. Drill another hole, next to connector and attach an appropriate ground connector.
 - c. Add cable, part no. 540516 (see wiring diagrams for 74801 -11 and 74802 -11).
 - d. Remove the relay located on the bottom of the Gum Bath or rewire to by-pass the relay per wiring diagrams for 74801 -11 and 7480211. Use wire leads supplied with controller to rewire bath.
 - e. Remove Type "E" thermocouple and replace with Type "J" thermocouple, part no. 322145.



The following corrections apply to instruction manual, TS-74801 AR-3;

Page 7 PARTS LIST:

Item No. 5, Relay, 50/60 Hz., part numbers 248010 or 248018 are not supplied on catalog no. 74801 or 74804 with serial numbers prefixed 11 or higher.

NOTE: The recently designed digital controller catalog no. 74802 -11, contains an internal solid state relay and heat sink.

Item No. 17, Thermocouple, Type 'E' part number 513542 can only be used with the Gum Baths (catalog numbers 74801 and 74804) with serial number prefixed 10, and with the "Gardsman" controller previously supplies by GCA.

Gum Baths with serial number prefixed 11 or higher require a Type 'J' thermocouple, part number 322145.

Item No. 25, Strain Relief Bushing, is employed on Gum Baths with serial numbers prefixed 10. Gum Baths with a serial number prefixed 11 or higher are furnished with Snub Bushing, Part No. 215199.

Page 4 ACCESSORIES:

Indicating and Controlling Pyrometer, should read: Temperature Controller/ Indicator, digital solid state, 120/240V. 50/60 Hz. 25/12.5 A. (O 599°F) catalog number 74802 (Serial No. 11 or higher).

Page 5 WIRING DIAGRAM:

HIGH TEMPERATURE BRONZE BLOCK GUM BATH CATALOG NO. 74801 (120V)

This wiring diagram applies to Gum Baths that contain a serial number prefixed with 10 only.

Page 6 WIRING DIAGRAM:

HIGH TEMPERATURE BRONZE BLOCK GUM BATH CATALOG NO. 74804 (240V)

This wiring diagram applies to Gum Baths that contain a serial number prefixed with 10 only.

Page 8 BOTTOM VIEW:

HIGH TEMPERATURE BRONZE BLOCK GUM BATH refers to Gum Baths with serial numbers prefixed 10, only.

BOTTOM VIEW (SERIAL NO. 11 OR HIGHER):

For cable connector and grounding locations see BOTTOM VIEW (SERIAL NO. 11 OR HIGHER) attached.

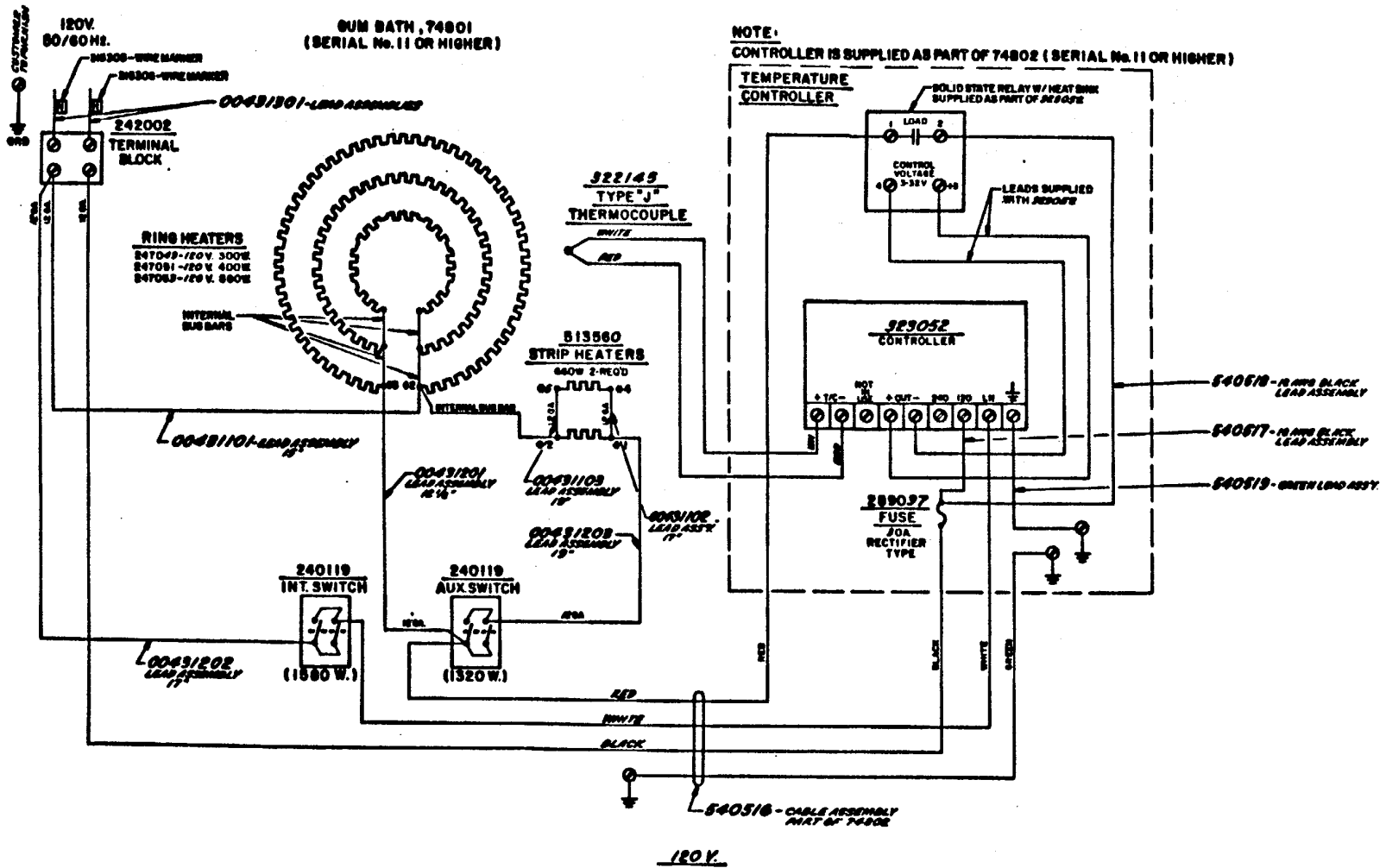

WIRING DIAGRAM
HIGH TEMPERATURE BRONZE BLOCK GUM BATH
CAT. NO. 74801 (SERIAL NO. 11 OR HIGHER)

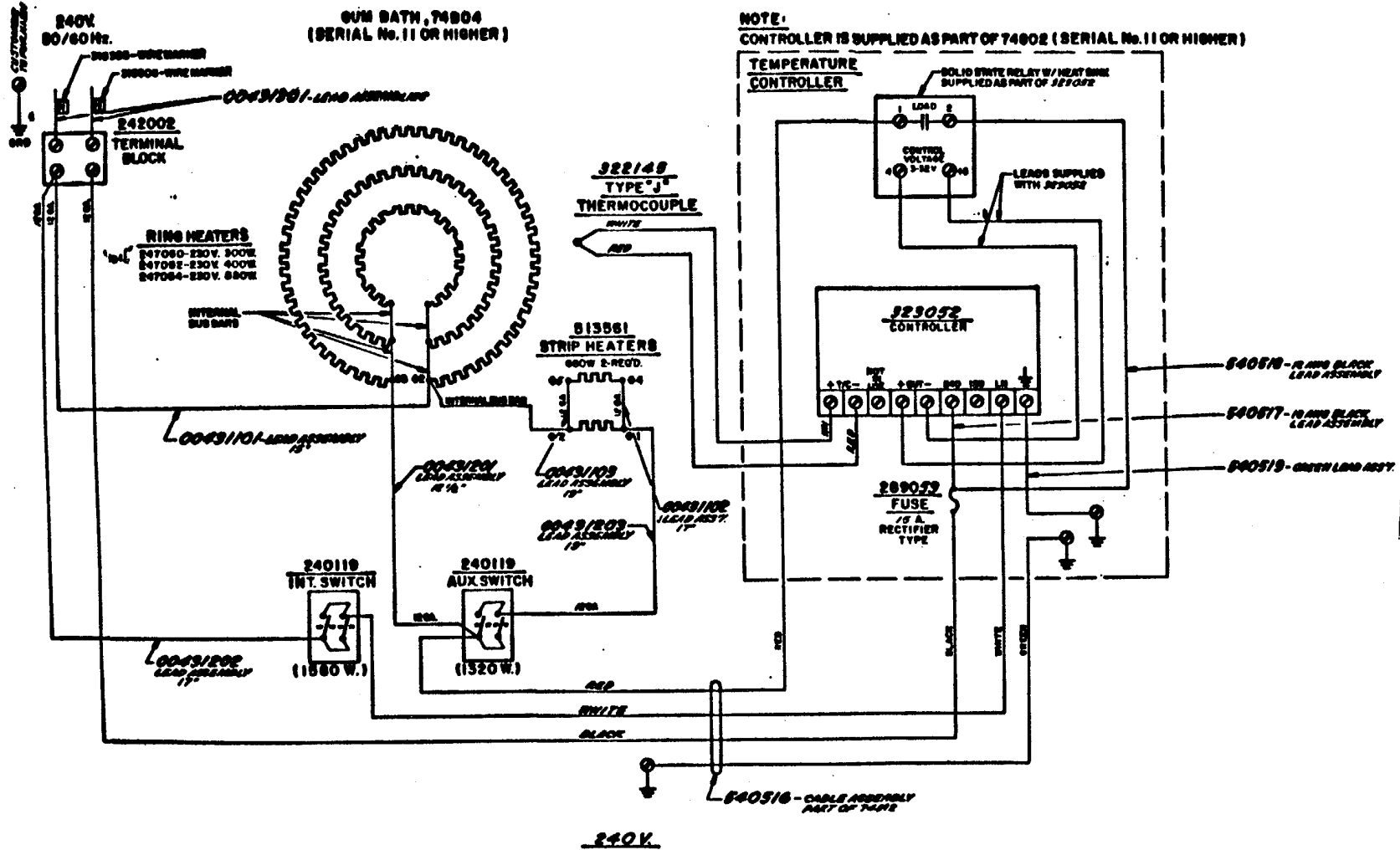

WIRING DIAGRAM
HIGH TEMPERATURE BRONZE BLOCK GUM BATH
CAT. NO. 74804 (SERIAL NO. 11 OR HIGHER)

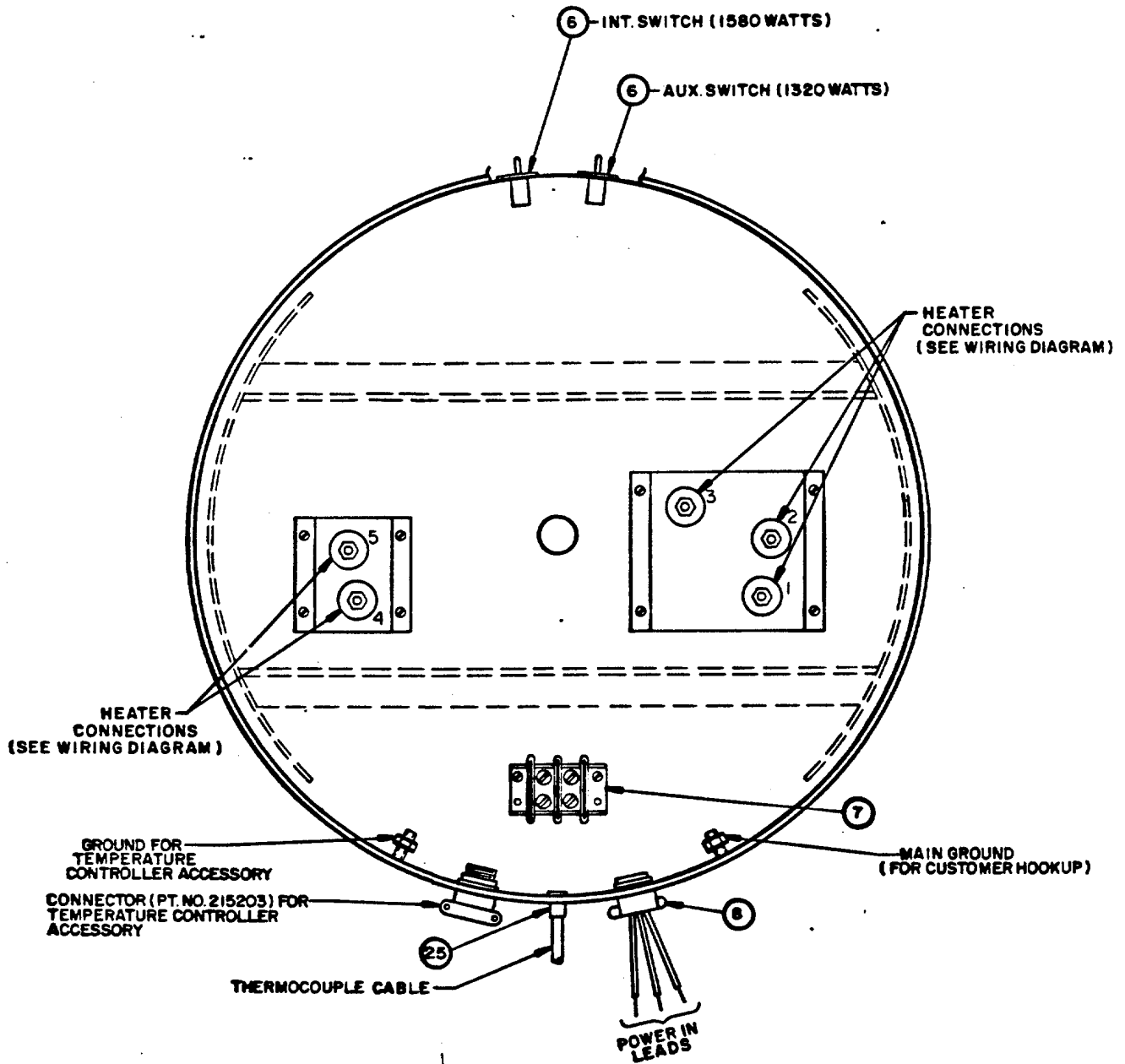

**BOTTOM VIEW (SERIAL NUMBER 11 OR HIGHER)
HIGH TEMPERATURE BRONZE BLOCK GUM BATH**

Precision™

Instruction Manual

TS074801 AR-3

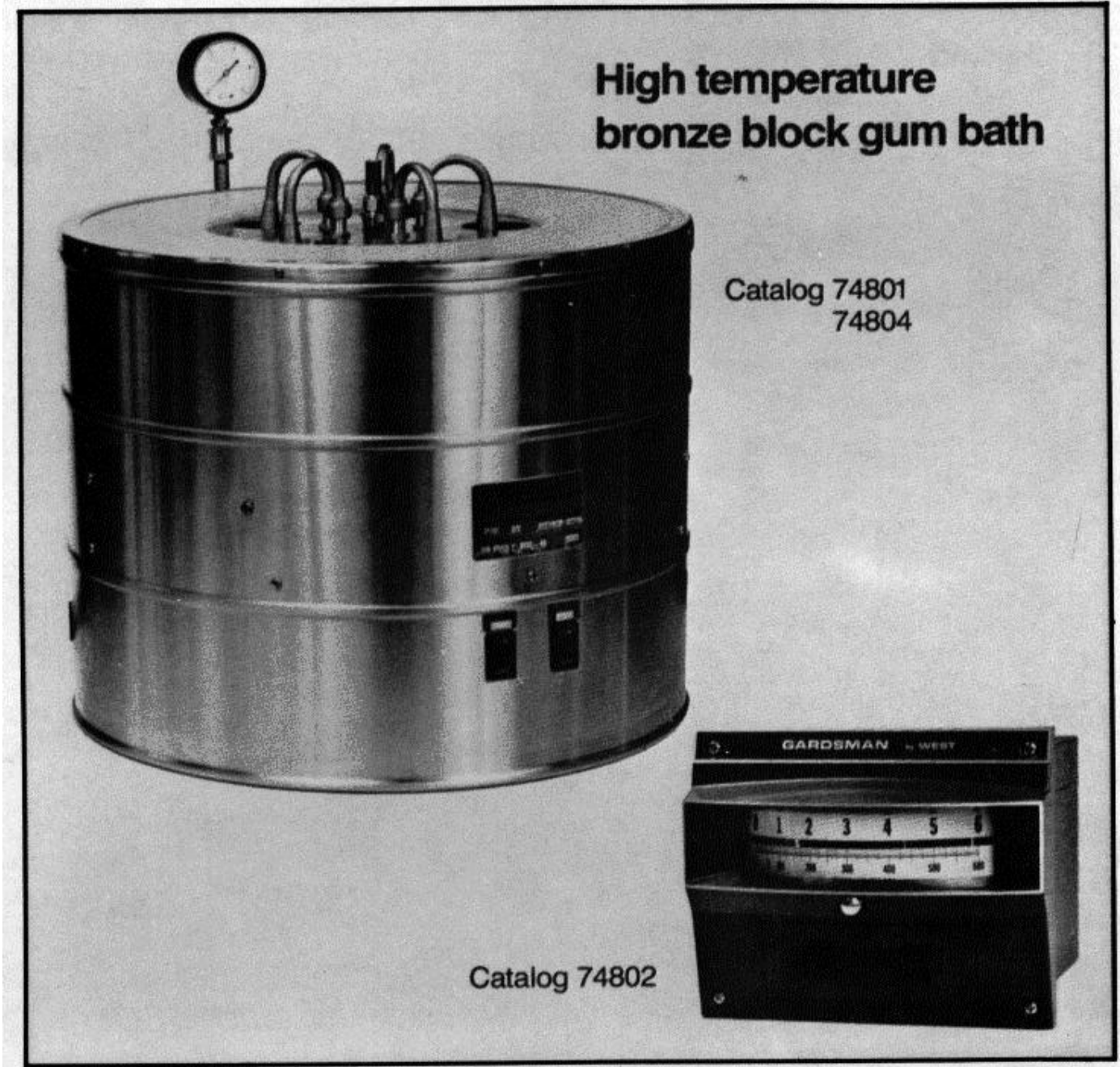



Precision Scientific Group
3737 West Cortland Street
Chicago, Illinois 60647
Telephone 312-X27-2660
Telex 25-4028

Precision™ Instruction Manual

TS-74801 AR-3

High temperature bronze block gum bath

Introduction

Your satisfaction and safety are important to GCA/PRECISION SCIENTIFIC, and a complete understanding of this unit is necessary to attain these objectives.

As the ultimate user of this apparatus, it is your responsibility to understand its proper function and operational characteristics. This instruction manual should be thoroughly read and all operators given adequate training before attempting to place this unit in service. Awareness of the stated cautions and warnings, and compliance with recommended operating parameters--together with maintenance requirements--are important for safe and satisfactory operation. The unit should be used for its intended application; alterations or modifications will void the Warranty.

WARNING: Always wear safety glasses when working with this apparatus, as a routine laboratory precaution.

This apparatus is not designed for use in Class I, II, or III locations as defined by the National Electrical Code.

Unpacking and damage

Save all packing material if apparatus is received damaged. This merchandise was carefully packed and thoroughly inspected before leaving our factory. Responsibility for its safe delivery was assumed by the carrier upon acceptance of the shipment; therefore, claims for loss or damage sustained in transit must be made upon the carrier by the recipient as follows:

Visible Loss or Damage: Note any external evidence of loss or damage on the freight bill, or express receipt, and have it signed by the carrier's agent. Failure to adequately describe such external evidence of loss or damage may result in the carrier's refusing to honor your damage claim. The form required to file such a claim will be supplied by the carrier.

Concealed Loss or Damage: Concealed loss or damage means loss or damage which does not become apparent until the merchandise has been unpacked and inspected. Should either occur, make a written request for inspection by the carrier's agent within 15 days of the delivery date; then file a claim with the carrier since the damage is the carrier's responsibility.

By following these instructions carefully, we guarantee our full support of your claim to be compensated for loss from concealed damage.

DO NOT -- FOR ANY REASON -- RETURN THIS UNIT WITHOUT FIRST OBTAINING AUTHORIZATION. In any correspondence to GCA/PRECISION SCIENTIFIC, please supply the nameplate data, including catalog number and serial number.



General information

These instructions encompass the high temperature Bronze Block Gum Baths listed below with their specific electrical characteristics:

<u>Cat No.</u>	<u>Volts</u>	<u>Hertz</u>	<u>Watts</u>	<u>Amps</u>
74801	120	50/60	2900	24
74804f	240	50/60	2900	12

The Gum Baths are designed to determine existent gum in motor gasoline, aviation gasoline, and turbine fuels, in accordance with ASTM D381 (1P-131).

WARNING: Gasoline and aviation fuel are extremely flammable and adequate ventilation should be provided during the test. (See the Annex in ASTM D-381; AI, Precautionary Statements For Additional Caution, Warning, and Danger Explanations.)

TECHNICAL SPECIFICATIONS

- Test Method Confirmation: ASTM D-381
 IP-131
 DIN-51766
 DIN-51784
- Maximum Temperature: 600°F
- Continuous Temperature: 475°F
- Air Flow Indication: 0 to 5 psig,
 graduated in one oz. divisions.
- Uniformity at 329°F (165°C):
 ±5°F (±3°C) each well.

Installation

Location: The most uniform operating conditions and results will be obtained by placing the unit in an area remote from drafts, ventilating outlets, radiators, and other rapidly changing ambient conditions.

Electrical Connections: Important
(Please read carefully.)

CAUTION: Be sure the power supply is of the same voltage as specified on the nameplate.

The Gum Bath is supplied with a terminal block located on the bottom of the bath and must be permanently connected to an electrical source by a qualified electrician.

WARNING: National Electrical Code should be observed for proper fusing and the size of the service wires. For personal safety, this apparatus must be properly grounded.

Air or Steam Connections: All connections should consist of at least 1/2" pipe and unions. This size has been designated to insure an adequate volume of air or steam being admitted to the bath. The rate of flow required is 1 liter per second, ±5%, and is determined by the flow/pressure gauge provided with this unit, as specified by ASTM D-381.

This flow/pressure gauge has been properly marked and calibrated in pounds and ounces, corresponding to the flow of air in liters per second. Calibrate according to description in ASTM D-381.

Note: A flowmeter reading of 600 mL/s for each outlet on a flowmeter calibrated at room temperature and atmospheric pressure will ensure delivery of 1000 ± 150mL/s at the temperature of 155 ± 5°C (311 + 9°F), provided the pressure on the outlet of the flowmeter is not greater than 5 psi (34.5 kPa).



If a stable air supply is not available, an air pressure regulator and reducer valve should be placed in the feed line. The Precision Air Pressure Regulator, Catalog #74803, may be ordered as an accessory item if such a regulator is required.

Thermometer Installation: Insert a thermometer (ASTM 3C or 3F, Temperature range 5 to + 400°C or 20 to 760°F) in the thermometer well provided in the center of the bath. The thermometer is not provided.

Pyrometer Connections: The Indicating and Controlling Pyrometer, Catalog No. 74802, is a recommended accessory for the Gum Bath.

Complete instructions are furnished with each Pyrometer, including wiring diagram and parts list, and should be referred to for all pertinent information.

See Gum Bath Schematic Wiring Diagrams for Indicating and Controlling Pyrometer Wire Connections.

Operation

Preparation of the apparatus, preparation of the sample, test procedure, calculations and reporting, and appropriate tables are supplied in the ASTM Method.

ASTM test methods can be obtained from:

American Society for Testing Materials
1916 Race Street
Philadelphia, Pennsylvania 19103

SAFETY CONSIDERATIONS AND WARNINGS:

The following guidelines are presented to supplement the existing safety rules enforced by your company:

1. Safety glasses should be worn by the operator and by anyone in the vicinity who could be struck by glass fragments caused by flask breakage or by splashing from handling liquid samples.
2. It is recommended that a fire extinguisher of Halon 1211 or CO₂ (at least a 5-lb. tank size) be placed conveniently in reach of the operator of the unit to protect against sample fires which might accidentally occur during testing.
3. Service or circuit testing should be attempted only by a qualified person who has been trained with regard to the potential danger of working with live electrical circuitry.

WARNING: Disconnect the unit from the power source whenever replacing electrical components.

4. Insulated gloves should be used when handling hot components.

Explanation of Switches:

The two switches, located on the front of the bath, control the power to the Controlling Pyrometer and the Auxiliary Strip Heaters.

The switch marked "AUX" is in series with the relay contacts and the 2 strip heaters, (660W each). When this switch is engaged, the strip heaters are turned "On" or "Off" through a set of relay contacts, the relay being energized by the Controlling Pyrometer.

The switch marked "INT" supplies power to the Controlling Pyrometer, which in turn controls the relay and the 3 ring heaters (300W, 400W, and 880W each).



PARTS LIST

CATALOG NUMBER			74801 120 Volts	74804 240 Volts
Item #	Qty.	Description	Part Number	
1	2	Heater, Strip, 660W	513560	513561
2	1	Heater, Ring Type, 880W (8-3/8"O.D.)	247053	247054
3	1	Heater, Ring Type, 400W (6-1/16"O.D.)	247051	247052
4	1	Heater, Ring Type, 300W (4" O.D.)	247049	247050
5	1	Relay, 50/60 Hz	248010	248018
6	2	Switch, 120/240V, "Int." and "Aux".		240119
7	1	Terminal Block		242002
8	1	Connector, 3/4"Greenfield		215008
9	1	Retainer, Top Insulation		513522
10	1	Top, Electrobestos		513523
11	5	Locknut		518456
12	5	Nozzle Assembly		518458
13	5	Nozzle Adapter		518455
14	1	Extension, Thermometer Tube		513525
15	1	Connection		513527
16	1	Tube, Thermometer		513526
17	1	Thermocouple		513542
18	5	Insulator, Porcelain		250028
19	1x8 ft.	Glasswool, 3 inch Thick		171802
20	1	Gauge, Flow/Pressure		252167
21	1	Coupling, 1/4		320362
22	1	Nipple Assembly		513519
23	1	Nipple, Air Inlet		513534
24	1	Plug		513535
25	1	Strain Relief Bushing		215003

ACCESSORIES

Indicating And Controlling Pyrometer	Cat. No.	74802
Air Or Steam Pressure Regulator	Cat. No.	74803

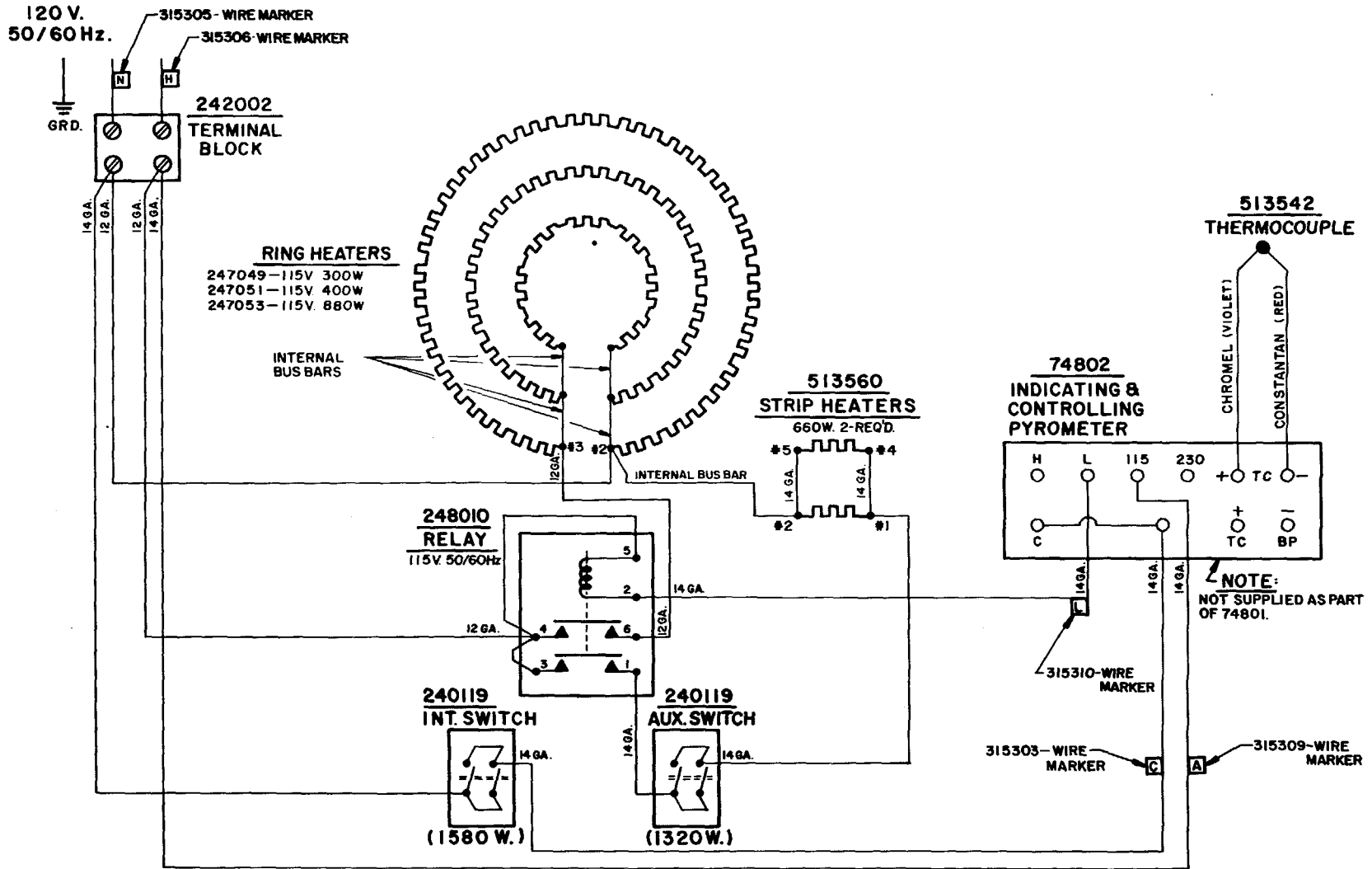

WIRING DIAGRAM
HIGH TEMPERATURE BRONZE BLOCK GUM BATH CAT. NO. 74801
(120 V.)

E.A.

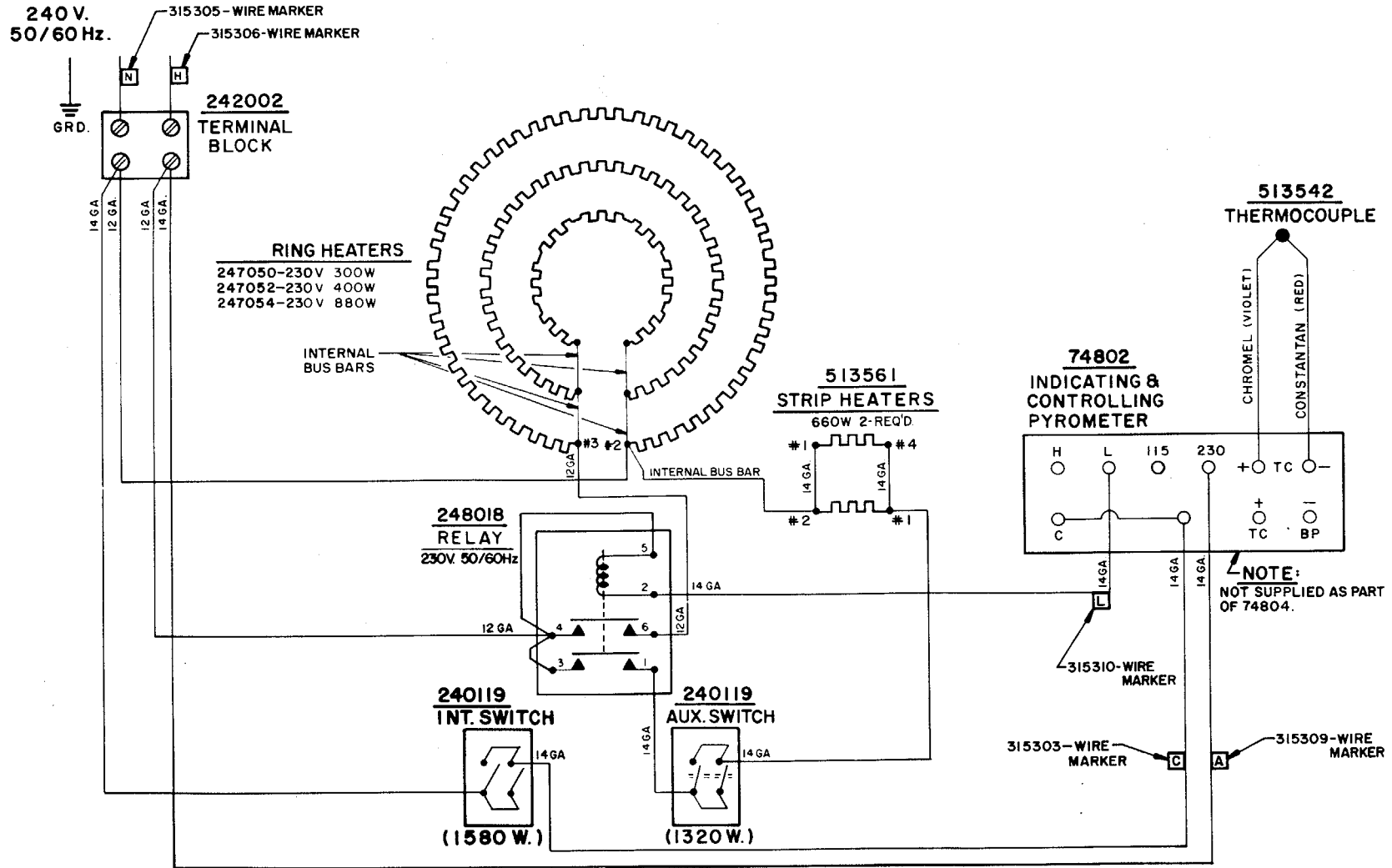

WIRING DIAGRAM
HIGH TEMPERATURE BRONZE BLOCK GUM BATH CAT. NO. 74804
(240 V.)

E.A.

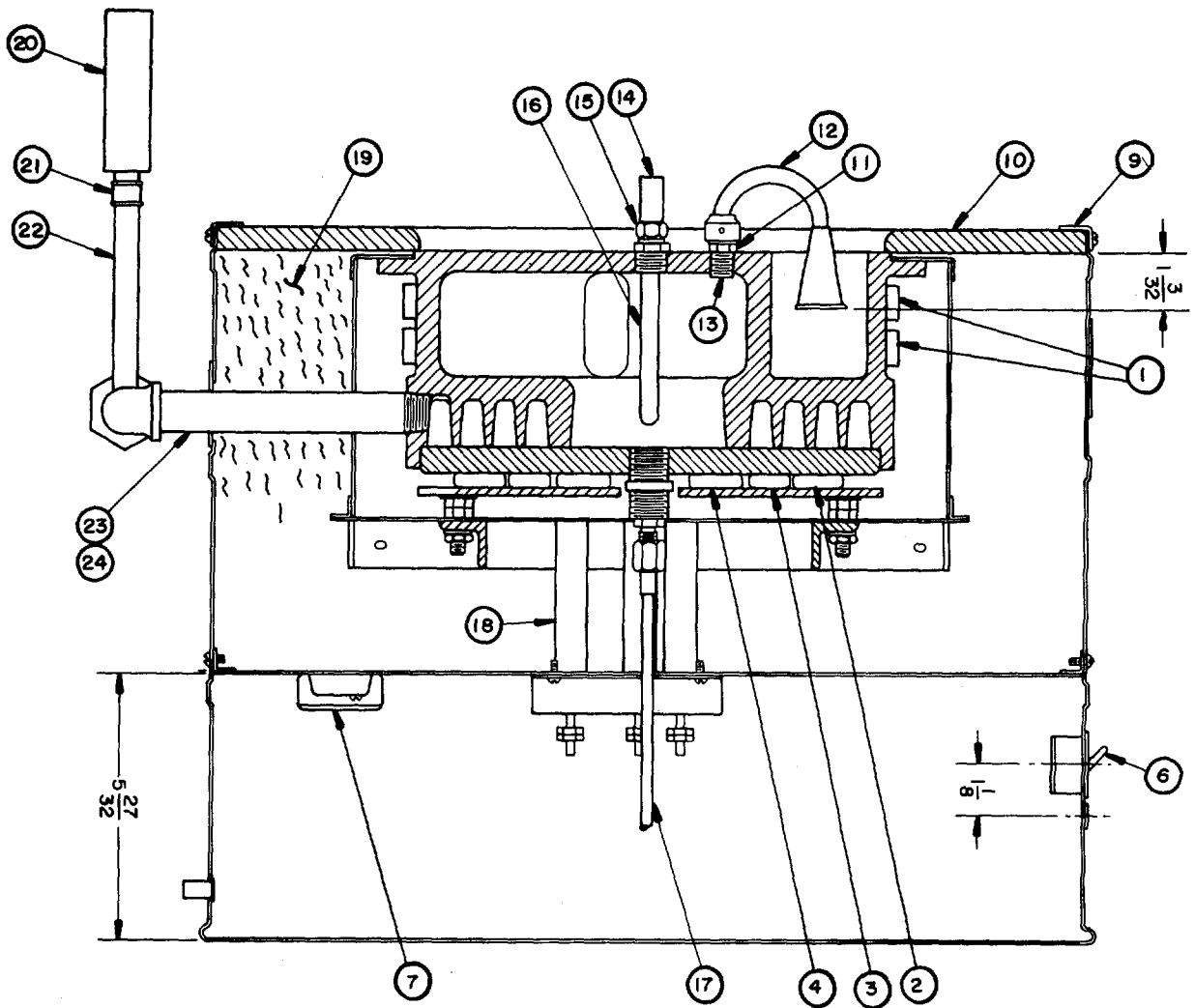

SIDE VIEW

HIGH TEMPERATURE BRONZE BLOCK GUM BATH

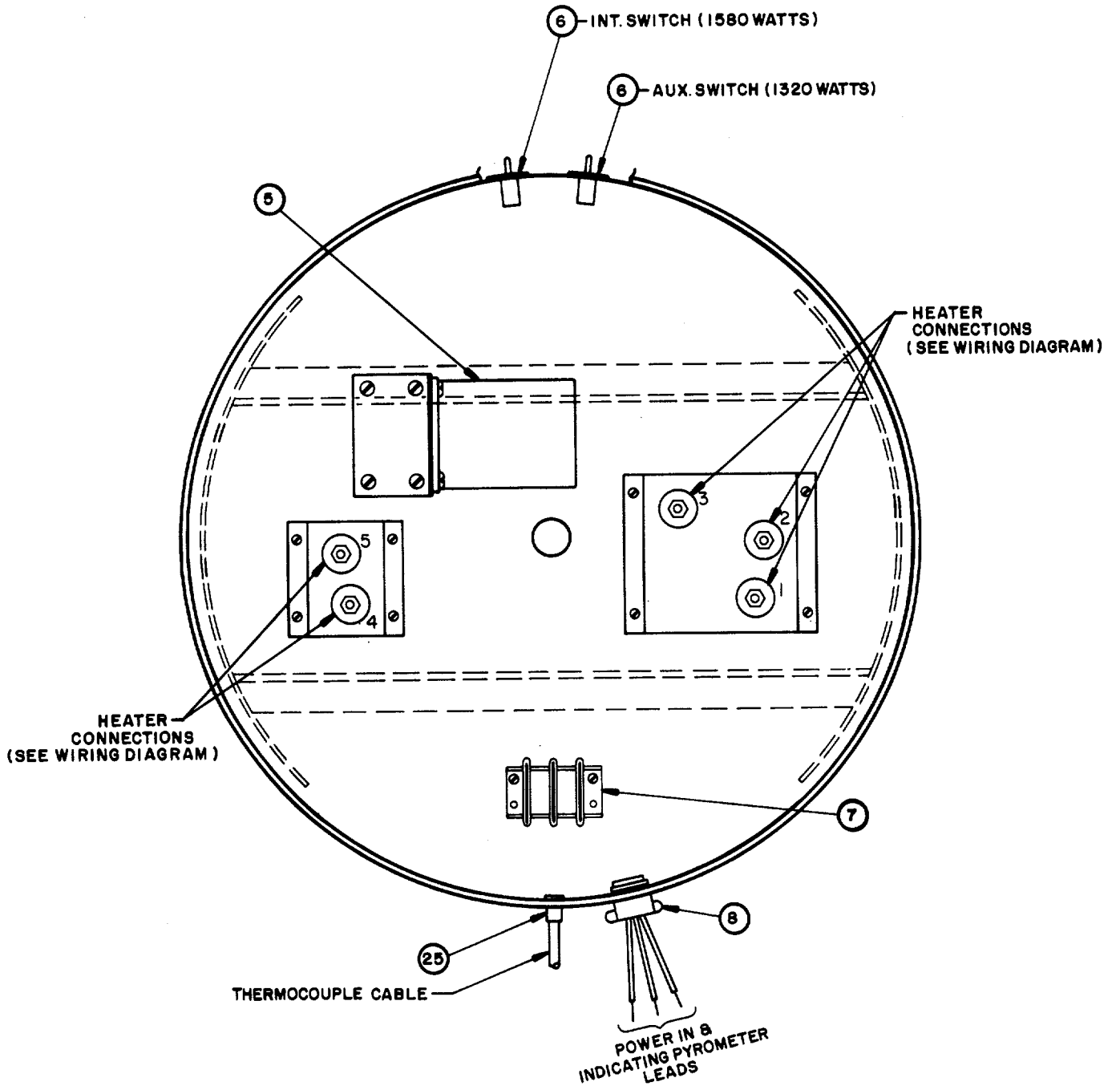

BOTTOM VIEW
 HIGH TEMPERATURE BRONZE BLOCK GUM BATH



Exclusive PRECISION Warranty

GCA/Precision Scientific Group (Precision) warrants its products against defects in material or in workmanship, when used under appropriate conditions and in accordance with appropriate operating instructions for a period of no less than one (1) year from the date of delivery of the products.

Precision's sole obligation shall be to repair or replace at Precision's option, F.O.B. its plant or locally, without charge, any part(s) that prove defective within the warranty period, provided the customer notifies Precision promptly and in writing of any such defect. Compensation for labor by other than Precision's employees will not be Precision's obligation. Part(s) replacement does not constitute an extension of the original warranty period.

PRECISION MAKES NO WARRANTY OF MERCHANTABILITY, FITNESS FOR A PARTICULAR PURPOSE, OR ANY OTHER WARRANTY, EXPRESSED OR IMPLIED, AS TO THE DESIGN, SALE, INSTALLATION, OR USE OF ITS PRODUCTS, AND SHALL NOT BE LIABLE FOR CONSEQUENTIAL DAMAGES RESULTING FROM THE USE OF ITS PRODUCTS.

Precision will not assume responsibility for unauthorized repairs or failure as a result of unauthorized product modifications, or for repairs, replacements, or modifications negligently or otherwise improperly made or performed by persons other than Precision employees or authorized representatives.

While Precision's personnel are available to advise customers concerning general applications of all manufactured products, oral representations are not warranties with respect to particular applications and should not be relied upon if inconsistent with product specifications or the terms stated herein.

In any event, the terms and conditions contained in Precision's formal sales contracts shall be controlling; and any changes must be in writing and signed by an authorized executive of the GCA/ Precision Scientific Group.

All defective components will be replaced without charge one year from the date of delivery. There will be no charge for labor if the apparatus is returned to the factory prepaid.

Conditions and qualifications of the warranty statement shall prevail at all times.

APPENDIX A

REFERENCES

A-1. **Scope.** This appendix contains all forms, pamphlets and technical manuals referenced in both the Air mobile and Semitrailer mounted Laboratories.

A-2. **Forms.**

Recommended Changes to Publications	DA Form 2028
.....	DA Form 2028-2
Quality Deficiency Report	SF 368
Equipment Inspection and Maintenance Work Sheet	DA Form 2404
Hand Receipts	DA Form 2062

A-3 **Field Manuals.**

Petroleum Testing Facilities:	
Laboratories and Kits	FM 10-72
Inspecting and Testing Petroleum Products	FM 10-70
ASTM Test Method Supplement to	FM 10-92C1/C2

A-4. **Technical Manuals.**

Atlas-Copco Compressor	TM 10-4310-392-13&P
Alcor Jet Fuel Thermal Oxidation Tester Operating and Maintenance Manual	TM 10-6635-210-13&P
Bacharach Gas Alarm and Calibration Data	TM 10-6665-297-13&P
Brother Portable Typewriter	TM 10-7430-218-13&P
Chemtrix Field Ph Meter	TM 10-6630-237-13&P
Elkay Manufacturing 30 GPH Cooler	TM 10-4130-240-13&P
Emcee Micro-Separometer	TM 10-6640-222-13&P
Foxboro Pressure Recording Gauge	TM 10-6685-365-13&P
Gammon Aqua Glo Water Detector	TM 10-6640-221-13&P
Gammon Mini Monitor Fuel Sampling Kit	TM 10-6630-230-13&P
Jelrus Burn-Out Furnace	TM 10-6640-231-13&P
Koehler Cleveland Open Tester	TM 10-6630-236-13&P
Koehler Cloud and Pour Point Chamber	TM 10-6630-238-13&P
Koehler Copper Strip Corrosion Bomb Bath	TM 10-6640-220-13&P
Koehler Distillation Apparatus	TM 10-6630-233-13&P
Koehler Dropping Point Apparatus	TM 10-6635-211-13&P
Koehler Electric Pensky-Martins Tester	TM 10-6630-231-13&P
Koehler Foaming Characteristics Determination Apparatus	TM 10-6640-228-13&P
Koehler Kinematic Viscosity Bath	TM 10-6630-239-13&P
Koehler Tag Closed Cup Flash Tester	TM 10-6630-235-13&P
Lab-Line Explosion Proof Refrigerator	TM 10-6640-219-13&P
Lily Freezer	TM 10-6640-234-13&P
Millipore OM 39 Filter Holder	TM 10-6640-225-13&P
Millipore Vacuum Pump	TM 10-6640-217-13&P
Ohaus Harvard Trip Balance	TM 10-6670-278-13&P
Precision Gas-Oil Distillation Test Equipment	TM 10-6630-219-13&P
Precision General Purpose Water Bath	TM 10-6640-229-13&P

Precision High Temperature Bronze Block Gum Bath	TM 10-6630-234-13&P
Precision General Purpose Ovens	TM 10-6640-218-13&P
Precision Heater Instruction Manual and Parts List	TM 10-6640-223-13&P
Precision Oxidation Stability Bath	TM 10-6640-232-13&P
Precision Pensky-Martens Flash Testers	TM 10-6630-231-13&P
Precision Reid Vapor Pressure Bath	TM 10-6640-226-13&P
Precision Slo-Speed Stirrer	TM 10-6640-224-13&P
Precision Universal Centrifuge	TM 10-6640-230-13&P
Precision Universal Penetrometer	TM 10-6640-228-13&P
Sargent-Welch Vacuum Pump	TM 10-4310-391-13&P
Sartorius Analytical Balance	TM 10-6670-277-13&P
Scotsman Cuber	TM 10-6640-227-13&P
Soltec VOM-Multimeter	TM 10-6625-3127-13&P
Teel Self-Priming Centrifugal Pump	TM 10-6640-217-13&P
Teel Submersible Pump	TM 10-4320-320-13&P
Texas Instrument TI-503011 Calculator	TM 10-7420-210-13&P
A-5. Pamphlets.	
The Army Maintenance Management System (TAMMS)	DA Pam 738-750
A-6. Miscellaneous Publications.	
The Army Integrated Publishing and Printing Program	AR 25-30
Laboratory, Airmobile, Aviation Fuel	MIL-L-52733A(ME)
Apparatus, Instruments, Chemicals, Furniture, and Supplies for Industrial, Clinical, College and Government Laboratories	Fisher Scientific Laboratories Catalog
Petroleum-Petrochemical Testing Equipment	Precision Scientific Catalog

APPENDIX B

MAINTENANCE ALLOCATION CHART

Section I. INTRODUCTION

B-1. **General.**

a. This section provides a general explanation of all maintenance and repair functions authorized at various maintenance categories.

b. The Maintenance Allocation Chart (MAC) in Section II designates overall authority and responsibility for the performance of maintenance functions on the identified end item or component. The application of the maintenance functions to the end item or component will be consistent with the capacities and capabilities of the designated maintenance categories.

c. Section III lists the tools and test equipment (both special tools and common tool sets) required for each maintenance function as referenced from Section II.

d. Section IV contains supplemental instructions and explanatory notes for a particular maintenance function.

B-2. **Maintenance Functions.** Maintenance functions will be limited to and defined as follows:

a. Inspect. To determine the serviceability of an item by comparing its physical, mechanical, and/or electrical characteristics with established standards through examination (e.g., by sight, sound, or feel).

b. Jest. To verify serviceability by measuring the mechanical, pneumatic, hydraulic, or electrical characteristics of an item and comparing those characteristics with prescribed standards.

c. Service. Operations required periodically to keep an item in proper operating condition, i.e., to clean (includes decontaminate, when required), to preserve, to drain, to paint, or to replenish fuel, lubricants, chemical fluids, or gases.

d. Adjust. To maintain or regulate, within prescribed limits, by bringing into proper or exact position, or by setting the operating characteristics to specified parameters.

e. Align. To adjust specified variable elements of an item to bring about optimum or desired performance.

f. Calibrate. To determine and cause corrections to be made or to be adjusted on instruments or test, measuring, and diagnostic equipments used in precision measurement. Consists of comparisons of two instruments, one of which is a certified standard of knob accuracy, to detect and adjust any discrepancy in the accuracy of the instrument being compared.

g. Remove/Install. To remove and install the same item when required to perform service or other maintenance functions. Install may be the act of emplacing, seating, or fixing into position a spare, repair part, or module (component or assembly) in a manner to allow the proper functioning of an equipment or system.

h. Replace. To remove an unserviceable item and install a serviceable counterpart in its place. "Replace" is authorized by the MAC and is shown as the third position code of the SMR code.

i. Repair. The application of maintenance services,¹ including fault location/troubleshooting,² removal/installation, and disassembly/assembly procedures³ and maintenance actions,⁴ to identify troubles and restore serviceability to an item by correcting specific damage, fault, malfunction, or failure in a part, subassembly, module (component or assembly), end item, or system.

j. Overhaul. That maintenance effort (service/action) prescribed to restore an item to a completely serviceable/operational condition as required by maintenance standards in appropriate technical publications (i.e., DMWR). Overhaul is normally the highest degree of maintenance performed by the Army. Overhaul does not normally return an item to like-new condition.

k. Rebuild. Consists of those services/actions necessary for the restoration of unserviceable equipment to a like-new condition in accordance with original manufacturing standards. Rebuild is the highest degree of materiel maintenance applied to Army equipment. The rebuild operation includes the act of returning to zero those age measurements (hours/miles, etc.) considered in classifying Army equipment/components.

B-3. Explanation Of Columns In The MAC, Section II.

a. Column 1. Group Number. Column 1 lists functional group code numbers, the purpose of which is to identify maintenance significant components, assemblies, subassemblies, and modules with the next higher assembly. End item group number shall be "00."

b. Column 2. Component/Assembly. Column 2 contains the names of components, assemblies, subassemblies, and modules for which maintenance is authorized.

c. Column 3. Maintenance Function. Column 3 lists the functions to be performed on the item listed in column 2. (For a detailed explanation of these functions, see paragraph B-2.)

d. Column 4. Maintenance Category. Column 4 specifies, by the listing of a work time figure in the appropriate subcolumn(s), the category of maintenance authorized to perform the function listed in column 3. This figure represents the active time required to perform that maintenance function at the indicated category of maintenance. If the number or complexity of the tasks within the listed maintenance function vary at different maintenance categories, appropriate work time figures will be shown for each category. The work time figure represents the average time required to restore an item (assembly, subassembly, component, module, end item, or system) to a serviceable condition under typical field operating conditions. This time includes preparation time (including any necessary disassembly/ assembly time), troubleshooting/fault location time, and quality assurance/quality control time in addition to the time required to perform the specific tasks identified for the maintenance functions authorized in the maintenance allocation chart. The symbol designations for the various maintenance categories are as follows:

¹ Services inspect, test, service, adjust, align, calibrate, and/or replace.

² Fault locate/troubleshoot the process of investigating and detecting the cause of equipment malfunctioning; the act of isolating a fault within a system or unit under test (UUT).

³ Disassemble/assemble encompasses the step-by-step taking apart (or breakdown) of a spare/functional group coded item to the level of its least component identified as maintenance significant (i.e., assigned an SMR code) for the category of maintenance under consideration.

⁴ Actions welding, grinding, riveting, straightening, facing, remachining, and/or resurfacing.

- C Operator/Crew
- O Unit Maintenance
- F Direct Support Maintenance
- H General Support Maintenance
- D Depot Maintenance

e. Column 5. Tools and Equipment. Column 5 specifies, by code, those common tool sets (not individual tools) and special tools, TMDE, and support equipment required to perform the designated function.

f. Column 6. Remarks. This column shall, when applicable, contain a letter code, in alphabetic order, which shall be keyed to the remarks contained in section IV.

B-4. Explanation Of Columns In Tool And Test Equipment Requirements, Section III.

- a. Column 1. Reference Code. The tool and test equipment reference code correlates with a code used in the MAC, section II, column 5.
- b. Column 2. Maintenance Category. The lowest category of maintenance authorized to use the tool or test equipment.
- c. Column 3. Nomenclature. Name or identification of the tool or test equipment.
- d. Column 4. National Stock Number. The National stock number of the tool or test equipment.
- e. Column 5. Tool Number. The manufacturer's part number.

B-5. Explanation Of Columns In Remarks, Section IV.

- a. Column 1. Reference Code. The code recorded in column 6, Section II.
- b. Column 2. Remarks. This column lists information pertinent to the maintenance function being performed as indicated in the MAC, section II.

Section II MAINTENANCE ALLOCATION CHART

(1) GROUP NUMBER	(2) COMPONENT/ ASSEMBLY	(3) MAINTENANCE FUNCTION	(4) MAINTENANCE LEVEL					(5) TOOLS AND EQUIPMENT	(6) REMARKS
			UNIT		DS	GS	DEPOT		
			C	O	F	H	D		
01	BATH, GUM	INSPECT REPLACE REPAIR	0.2	0.5 1.0	4.0			1, 2	A, B

**SECTION III. TOOL AND TEST EQUIPMENT REQUIREMENTS
FOR MAINTENANCE ALLOCATION CHART**

(1) Reference Number	(2) Maintenance Level	(3) Nomenclature	(4) National/NATO Stock Number	(5) Tool Number
1	O, F	TOOL KIT, GENERAL AUTOMOTIVE	5180-00-177-7033	(50980) SC 5180-90- CL-N26
2	O, F	MULTIMETER, 0-500V	6625-00-691-2453	

Section IV. REMARKS

REFERENCE CODE	REMARKS
A	Repair limited to the replacement of parts listed in manual.
B	Repairs at organization limited to replacement of switches, plugs and cords, flow pressure gauge assembly, thermometer tube/assembly and nozzle assembly.

APPENDIX C

COMPONENTS OF END ITEM AND BASIC ISSUE ITEMS LISTS

NOT APPLICABLE

C-1/(C-2 Blank)

APPENDIX D

ADDITIONAL AUTHORIZATION LIST

Section I. INTRODUCTION

D-1. Scope.

This appendix lists additional items you are authorized for the support of the Precision High Temperature Bronze Block Gum Bath.

D-2. General.

This list identifies items that do not have to accompany the Precision High Temperature Bronze Block Gum Bath and that do not have to be turned in with it. These items are authorized to you by CTA, MTOE, TDA, or JTA.

D-3. Explanation of Listing.

National stock numbers, descriptions and quantities are provided to help you identify and request the additional items you require to support this equipment. The items are listed in alphabetical sequence by item name under the type of document (i.e., CTA, MTOE, TDA, or JTA) which authorizes the item(s) to you.

(1) National Stock Number	(2) Description CAGEC And Part Number	(3) Qty U/M	(4) Auth
	INDICATING AND CONTROLLING PYROMETER (48619) 74802	EA	1
	AIR OR STEAM PRESSURE REGULATOR (48619) 74803	EA	1

APPENDIX E
EXPENDABLE/DURABLE SUPPLIES AND MATERIALS LIST

NOT APPLICABLE

E-1/(E-2 Blank)

By Order of the Secretary of the Army:

CARL E. VUONO
General, United States Army
Chief of Staff

Official:

THOMAS F. SIKORA
Brigadier General, United States Army
The Adjutant General

DISTRIBUTION:

To be distributed in accordance with DA Form 12-21A, (qty. rqr bl no. 520) Operator, Unit and Direct Support Maintenance requirements for Laboratory, Petroleum, MTD

RECOMMENDED CHANGES TO EQUIPMENT TECHNICAL PUBLICATIONS

 <p style="text-align: center;"><i>THEN...JOT DOWN THE DOPE ABOUT IT ON THIS FORM. CAREFULLY TEAR IT OUT, FOLD IT AND DROP IT IN THE MAIL.</i></p>		SOMETHING WRONG WITH PUBLICATION		
		FROM: (PRINT YOUR UNIT'S COMPLETE ADDRESS)		
PUBLICATION NUMBER		DATE SENT		
PUBLICATION DATE		PUBLICATION TITLE		
BE EXACT PIN-POINT WHERE IT IS				
PAGE NO.	PARA-GRAPH	FIGURE NO.	TABLE NO.	<p style="font-weight: bold; margin-top: 0;">IN THIS SPACE, TELL WHAT IS WRONG AND WHAT SHOULD BE DONE ABOUT IT.</p>
PRINTED NAME, GRADE OR TITLE AND TELEPHONE NUMBER			SIGN HERE	

The Metric System and Equivalents

Linear Measure

1 centimeter = 10 millimeters = .39 inch
 1 decimeter = 10 centimeters = 3.94 inches
 1 meter = 10 decimeters = 39.37 inches
 1 dekameter = 10 meters = 32.8 feet
 1 hectometer = 10 dekameters = 328.08 feet
 1 kilometer = 10 hectometers = 3,280.8 feet

Weights

1 centigram = 10 milligrams = .15 grain
 1 decigram = 10 centigrams = 1.54 grains
 1 gram = 10 decigram = .035 ounce
 1 decagram = 10 grams = .35 ounce
 acres
 1 hectogram = 10 decagrams = 3.52 ounces
 1 kilogram = 10 hectograms = 2.2 pounds
 1 quintal = 100 kilograms = 220.46 pounds
 1 metric ton = 10 quintals = 1.1 short tons

Liquid Measure

1 centiliter = 10 milliliters = .34 fl. ounce
 1 deciliter = 10 centiliters = 3.38 fl. ounces
 1 liter = 10 deciliters = 33.81 fl. ounces
 1 dekaliter = 10 liters = 2.64 gallons
 1 hectoliter = 10 dekaliters = 26.42 gallons
 1 kiloliter = 10 hectoliters = 264.18 gallons

Square Measure

1 sq. centimeter = 100 sq. millimeters = .155 sq. inch
 1 sq. decimeter = 100 sq. centimeters = 15.5 sq. inches
 1 sq. meter (centare) = 100 sq. decimeters = 10.76 sq. feet
 1 sq. dekameter (are) = 100 sq. meters = 1,076.4 sq. feet
 1 sq. hectometer (hectare) = 100 sq. dekameters = 2.47
 1 sq. kilometer = 100 sq. hectometers = .386 sq. mile

Cubic Measure

1 cu. centimeter = 1000 cu. millimeters = .06 cu. inch
 1 cu. decimeter = 1000 cu. centimeters = 61.02 cu. inches
 1 cu. meter = 1000 cu. decimeters = 35.31 cu. feet

Approximate Conversion Factors

<i>To change</i>	<i>To</i>	<i>Multiply by</i>	<i>To change</i>	<i>To</i>	<i>Multiply by</i>
inches	centimeters	2.540	ounce-inches	Newton-meters	.007062
feet	meters	.305	centimeters	inches	.394
yards	meters	.914	meters	feet	3.280
miles	kilometers	1.609	meters	yards	1.094
square inches	square centimeters	6.451	kilometers	miles	.621
square feet	square meters	.093	square centimeters	square inches	.155
square yards	square meters	.836	square meters	square feet	10.764
square miles	square kilometers	2.590	square meters	square yards	1.196
acres	square hectometers	.405	square kilometers	square miles	.386
cubic feet	cubic meters	.028	square hectometers	acres	2.471
cubic yards	cubic meters	.765	cubic meters	cubic feet	35.315
fluid ounces	milliliters	29,573	cubic meters	cubic yards	1.308
pints	liters	.473	milliliters	fluid ounces	.034
quarts	liters	.946	liters	pints	2.113
gallons	liters	3.785	liters	quarts	1.057
ounces	grams	28.349	liters	gallons	.264
pounds	kilograms	.454	grams	ounces	.035
short tons	metric tons	.907	kilograms	pounds	2.205
pound-feet	Newton-meters	1.356	metric tons	short tons	1.102
pound-inches	Newton-meters	.11296			

Temperature (Exact)

°F	Fahrenheit	5/9 (after	Celsius	°C
	temperature	subtracting 32)	temperature	

This fine document...

Was brought to you by me:



[Liberated Manuals -- free army and government manuals](#)

Why do I do it? I am tired of sleazy CD-ROM sellers, who take publicly available information, slap “watermarks” and other junk on it, and sell it. Those masters of search engine manipulation make sure that their sites that sell free information, come up first in search engines. They did not create it... They did not even scan it... Why should they get your money? Why are not letting you give those free manuals to your friends?

I am setting this document FREE. This document was made by the US Government and is NOT protected by Copyright. Feel free to share, republish, sell and so on.

I am not asking you for donations, fees or handouts. If you can, please provide a link to liberatedmanuals.com, so that free manuals come up first in search engines:

<A HREF=<http://www.liberatedmanuals.com/>>Free Military and Government Manuals

- Sincerely
Igor Chudov
<http://igor.chudov.com/>
- [Chicago Machinery Movers](#)