

DEPARTMENT OF THE ARMY TECHNICAL MANUAL

---

DIRECT AND GENERAL SUPPORT AND  
DEPOT MAINTENANCE MANUAL

TRUCK, LIFT, FORK, ELECTRIC  
SOLID RUBBER TIRES  
6000 POUND CAPACITY  
ARMY MODEL MHE-198  
BAKER MODEL FTD-060-EE  
FSN 3930-724-4057, 130 IN. LIFT  
FSN 3930-724-4059, 172 IN. LIFT

---

HEADQUARTERS, DEPARTMENT OF THE ARMY

TAGO 8176A

APRIL 1965

## SAFETY PRECAUTIONS

### OPERATION

Refer to TM 10-3930-256-10 for safety precautions to be observed during operation of the fork lift truck.

### HYDRAULIC SYSTEM

Before working on any part of the hydraulic system, be sure:

1. Lift carriage is fully lowered.
2. Mast is tilted fully DOWN.
3. All hydraulic pressure is relieved from unit or hose to be serviced.
4. All personnel and materiel are clear, should some system be operated accidentally.
5. Disconnect battery at charging receptacle, except when battery power is required to support the maintenance being done.

### ELECTRICAL SYSTEM

1. Avoid contact with spilled electrolyte. It is corrosive to most metals and fabrics and can burn skin if not washed off immediately with running water.
2. Be very careful of flame, smoking, or creating sparks by short circuiting near charging or recently charged batteries. Hydrogen gas given off during charging is explosive and easily ignited.
3. Disconnect battery at charging receptacle, except when battery is needed to support maintenance being done.
4. Remove rings, metal watch bands, or any object which might short across the electrical circuit. Serious burns can result, and equipment can be damaged, if this is not done.

**DIRECT AND GENERAL SUPPORT  
AND DEPOT MAINTENANCE MANUAL**

**TRUCK, LIFT, FORK, ELECTRIC,  
SOLID RUBBER-TIRED WHEELS  
6,000 POUND CAPACITY  
BAKER MODEL TD -EE, ARMY MODEL MHE 198  
CONTRACT NUMBER DSA 020628-MP302  
FSN 3930-724-4057 (130 INCH LIFT)  
FSN 3930-724-4059 (172 INCH LIFT)**

---

			Paragraph	Page
CHAPTER Section	1.	INTRODUCTION		
	I.	GENERAL		
		Scope .....	1	3
		Appendixes.....	2	3
		Maintenance forms and records.....	3	3
		Reporting of equipment manual improvements .....	4	3
		Orientation.....	5	3
	II.	DESCRIPTION AND DATA		
		Description .....	6	3
		Tabulated data .....	7	3
CHAPTER Section	2.	MAINTENANCE INSTRUCTIONS		
	I.	TROUBLESHOOTING		
		Troubleshooting.....	8	6
	II.	ELECTRICAL SYSTEM		
		Horn button wiring .....	9	10
		Wiring, head-, tail- and stop lights.....	10	10
	III.	FRONT AXLE		
		General.....	11	15
		Power axle ends .....	12	15
		Power axle assembly, complete.....	13	15
		Drive gear.....	14	21
		Drive axle adapter (including coupling) .....	15	21
	IV.	REAR AXLE		
		Steering axle .....	16	23
		Steering knuckles, pins and bearings .....	17	26
	V.	BRAKES		
		General.....	18	26
		Parking brake system.....	19	26
		Brake assembly.....	20	26
		Brake master cylinder.....	21	26
		Brake pedal and linkage.....	22	27
	VI.	WHEELS		
	Wheels .....	23	29	
	Tires .....	24	29	

Section		Paragraph	Page
	VII. STEERING		
	Steering gear.....	25	30
	Tie rods .....	26	44
	Bell crank.....	27	44
	Steering pump.....	28	44
	VIII. HYDRAULIC LIFT COMPONENTS		
	Hydraulic pump .....	29	48
	Hydraulic control valve .....	30	49
	Hydraulic tilt cylinders.....	31	51
	Lift cylinder (130 inch lift).....	32	51
	Crosshead assembly (130 inch lift) .....	33	52
	Inner upright assembly (130 inch lift) .....	34	52
	Lift cylinder (172 inch lift).....	35	54
	Crosshead, inner upright, and carriage assembly.....	36	57
	Hydraulic oil tank.....	37	57
	IX. ELECTRIC MOTORS		
	General.....	38	60
	Travel motor 9 .....	39	62
	Hydraulic pump motor .....	40	64
	Steering motor.....	41	64
	Electrical equipment box cover .....	42	67
	Relays.....	43	68
	Fuseholder assembly .....	44	68
	Directional switch .....	45	68
APPENDIX	I. REFERENCES.....		70
	II. MAINTENANCE ALLOCATION .....		72
	III. REPAIR PARTS AND SPECIAL TOOL LISTS .....		73
	IV. DIRECT AND GENERAL SUPPORT MAINTENANCE SUPPORT OF ORGANIZATIONAL LEVEL SERVICE ON RECEIPT OF NEW EQUIPMENT .....		74

## CHAPTER 1

### INTRODUCTION

---

#### Section I. GENERAL

##### 1. Scope

These instructions are published for the use of personnel responsible for direct and general support and depot maintenance of Truck, Lift, Fork, Electric, Solid Rubber Tired Wheels, 6,000 Pound Capacity, Baker Model FTD-060- EE, Army Model MHE 198, Federal Stock Number 3930-724-4057 (130 inch lift), Federal Stock Number 3930-724-4059 (172 inch lift). Instructions in this manual are applicable to trucks procured under contract number DSA- 4-020628-MP302.

##### 2. Appendixes

Appendixes with references applicable to direct and general support and depot maintenance are as follows:

- a. Appendix I is a list of current references.
- b. Appendix II, Maintenance Allocation Chart, is published only in TM 10-3930-256 20.
- c. Appendix III, Repairs Parts and Special Tool Lists, is published under separate cover TM 103930-256-35P.
- d. Appendix IV contains the Direct and General Support maintenance support of Organizational level service on receipt of new equipment.

##### 3. Maintenance Forms and Records

The maintenance forms, records, and reports

to be used in direct and general support and depot maintenance of this truck are listed and described in TM 38-750.

##### 4. Reporting of Equipment Manual Improvements

- a. The direct reporting by the individual user of errors, omissions, and recommendations for improving this manual is authorized and encouraged. DA Form 2028 (Recommended Changes to DA Publications) will be used for reporting these improvements. This form will be completed in triplicate using pencil, pen, or typewriter. The original and one copy will be forwarded direct to Commanding General, U.S. Army Mobility Equipment Center: ATTN: SMOME-MMP, Post Office Drawer 58, St. Louis, Mo. 63166. One information copy will be provided to the individual's immediate supervisor (e.g., officer, noncommissioned officer, supervisor, etc.).
- b. Report all equipment improvement recommendations as prescribed by TM 38-750.

##### 5. Orientation

Throughout this manual, the use of the terms right, left, front, and rear, indicates directions from the viewpoint of the operator sitting in the seat of the truck, unless it is obvious from the text this is not intended.

#### Section II. DESCRIPTION AND DATA

##### 6. Description

Refer to TM 10-3930-25620 for a general description of the truck.

##### 7. Tabulated Data

Refer also to TM 10-3930-25610 and TM 10-3930-25620 for tabulated data related to the organizational maintenance level.

a. *Electrical System (fig. 1).*

- |   |   |
|---|---|
| (1) Battery type                                  | GFE (Government Furnished Equipment), either lead-acid or nickel-iron, alkaline electrolyte. 36 volt, dc, two-wire, battery, spark enclosed.            |
| (2) Motors Steer motor, pump motor, travel motor. |   |
| (a) Type  | Series wound, relay energized.  |
| (b) Overload protection                           | Thermal relays (on motor housings)<br>Fuses (in control circuit)<br>Fusetrons (in motor lines)  |
| (c) Steer motor                                   | Controlled by seat actuated switch. Constant run when operator is seated. Loaded only when steer effort is required.<br>Constant speed.                 |
| (d) Pump motor                                    | Controlled by lift and tilt valve actuated switch. Runs only as needed. Constant speed.   |
| (e) Travel motor                                  | Reversible. Four speeds available. Reversing by reversing field current polarity. Speed and power control by selection of resistances in motor circuit. |
| (f) Travel motor controls                         |   |
| 1. Direction                                      | Directional control switch on steering column. Forward-Off-Reverse.   |
| 2. Speed  | Accelerator master assembly. Three micro switches energize control relays in sequence. Time delay acceleration and plugging control incorporated.       |

b. *Hydraulic Systems.*

- |   |   |
|---|---|
| (1) System pressure (lift)                | 1800 psi relief valve setting                         |
| (2) Hoist speed empty (both lift heights) | 36 fpm  |
| (3) Hoist speed loaded                    | 22 fpm  |
| (4) Main pump                             |   |
| (a) Type                                  | Gear  |
| (b) Capacity (rated)                      | 6.4 gpm at 1000 psi and 1200 rpm                      |
| (c) Actuation                             | Switch at lift and tilt control                       |
| (5) Steer pump                            |   |
| (a) Type                                  | Vane  |
| (b) Capacity                              | 1.5 gpm at 1000 psi and 1200 gpm                      |
| (c) Actuation                             | By truck seat occupancy (micro switch). Constant run. |
| (6) Power steering                        | Saginaw   |
| (a) Type                                  | Rotary valve  |
| (b) Hydraulic system type                 | Open center. Pressure only on demand.                 |

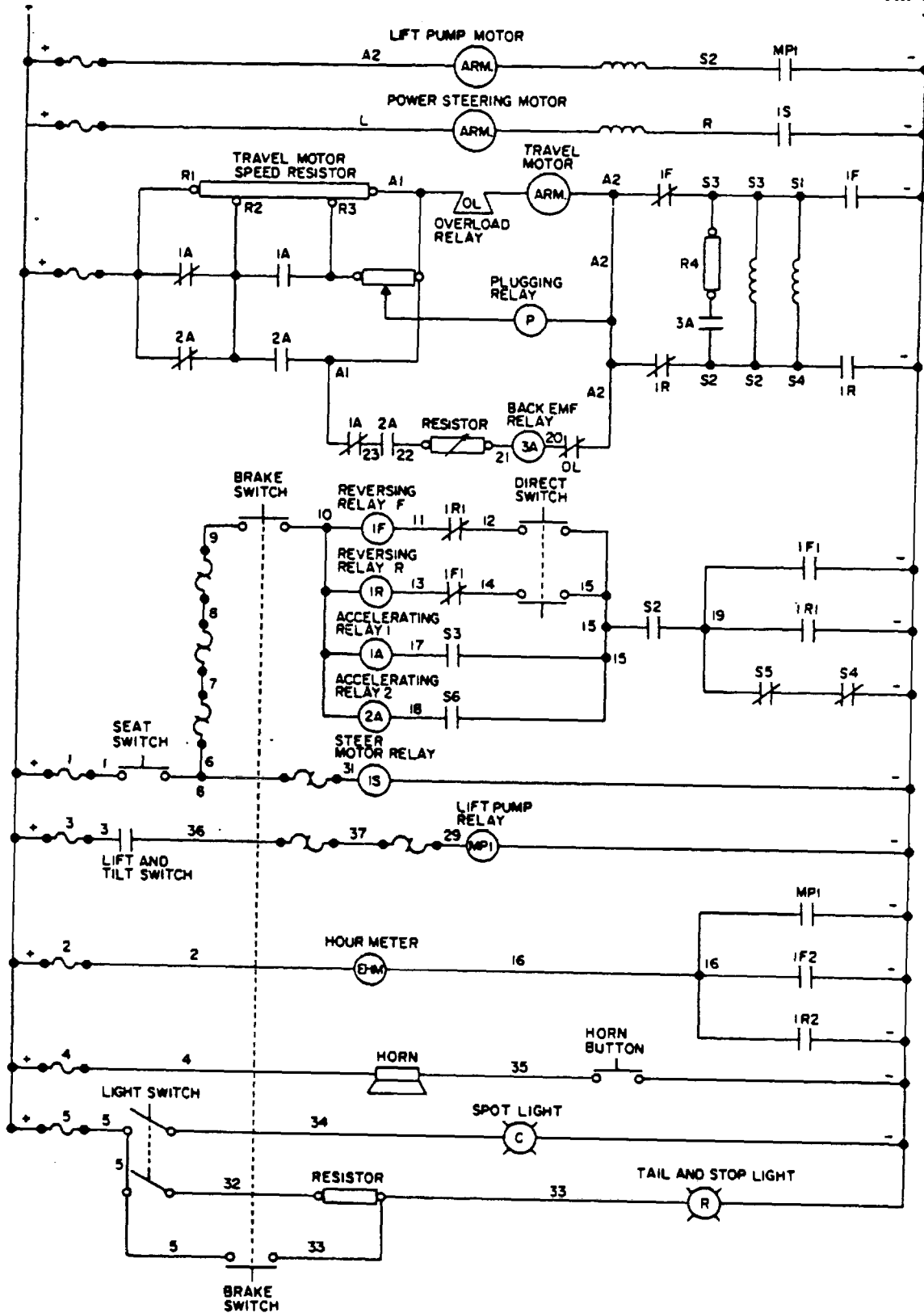

MEC 3930-256-35/1

Figure 1. Schematic wiring diagram.

CHAPTER 2

MAINTENANCE INSTRUCTIONS

Section I. TROUBLESHOOTING

8. Troubleshooting

This paragraph contains, in tabular form, guidance in locating causes of trouble. Some mal- functions of equipment will give more than one symptom. For this reason, determine from the operator when possible all complaints on truck performance. Compare these complaints with all "Trouble" entries in the chart, to find a common cause for the complaints. This procedure will usually save time and effort. A troubleshooting chart, with remedies limited to organizational maintenance capabilities, is included in TM 10-3930-256-20. A separate troubleshooting chart for power steering situations is at the end of the paragraph covering service of the steering gear (par. 25).

a. Electrical.

(1) Truck will not start or develop full power.

<i>Probable cause</i>	<i>Remedy</i>
Dead battery .....	Replace or charge (TM 10-3930-256-10).
Fusetron blown.....	Replace (TM 10-3930-256-20).
Defective battery plug or receptacle.....	Replace plug or receptacle (TM 10-3930-256-20).
Braided shunt in relay broken .....	Replace shunt.
Contacts dirty, worn or broken in relay or directional .....	Clean contact tips: replace if necessary (TM 10-3930-256-20).
switch.	
Dirt in relay causing mechanical binding .....	Clean contactor thoroughly (TM 10-3930-256-20).
Mechanical binding in contractor or accelerating .....	Adjust or replace defective parts (TM 10-3930-256-20).
switch.	
Pole faces of plugging relay magnet not sealing prop- .....	Clean, adjust or replace (TM 10-3930-256-20).
erly.	
Snap switches malfunctioning in accelerator switch .....	Replace and adjust as necessary (TM 10-3930-256-20).
Seat switch not working .....	Adjust or replace switch (TM 10-3930-256-20).
Open circuit due to loose connections in master switches.	Clean and secure connections firmly (TM 10-3930-256-20).

(2) All speeds not obtainable.

<i>Probable cause</i>	<i>Remedy</i>
Open in relay main circuit .....	Locate and eliminate.
Pole faces of plugging relay magnet not making good.....	Clean, adjust, or replace defective parts (TM 10-3930-25620).
contact.	
Object lodged in relay contact .....	Remove .object.
Dirty contacts .....	Clean or replace contacts (TM 103930-256-20).
Snap switches in accelerating master malfunctioning.....	Replace snap switches on roller arm and yoke as necessary (TM 10-3930-256-20).
Sticking or binding of accelerator in any part of stroke .....	Correct binding of the accelerator.

(3) Overheating.

<i>Probable cause</i>	<i>Remedy</i>
Dirty contacts .....	Clean contacts
Broken, worn or improperly adjusted brushes or brush.....	Adjust or replace brushes or brush holders (para. 37).
holders in travel motor.	
Vehicle operating in low speed for prolonged periods .....	Check operation.



(4) *Improper plugging control and timing through all speeds.*

<i>Probable cause</i>	<i>Remedy</i>
Sticking of the accelerator stroke in master switch .....	Correct binding.
Improper timing through all speeds .....	Adjust timing (TM 10-3930-2520).
Shorted wires.....	Locate and eliminate short.
Open relay contact in main circuit .....	Locate and correct.
Dirt in relay or directional switch.....	Clean unit thoroughly (TM 10-3930-256-20).
Dirty contacts in contractor or directional switch .....	Clean contacts, or replace (TM 10-3930-25620).

*b. Brakes.*

(1) *Brakes dragging.*

<i>Probable cause</i>	<i>Remedy</i>
Master cylinder compensating port plugged.....	Overhaul master cylinder (para. 21).
Seat brake improperly adjusted.....	adjust so that brake does not drag when seat is down, and is firmly applied when seat is up (TM 10-3930-256-20).
Mineral oil in brake system.....	Drain and flush system, replace all cups, and service as required (paras. 20 and 21).
Improper service brake adjustment .....	Adjust brakes (TM 10-3930-25620).

(2) *Brake pedal goes to floor.*

<i>Probable cause</i>	<i>Remedy</i>
Worn lining .....	Adjust lining clearance (TM 10-3930-256-20), or install new lining (para. 20).
Air in system .....	Bleed system (TM 10-3930-256-20).
Improper brake adjustment .....	Adjust brake shoes (TM 10-3930-25-20).
Fluid low in master cylinder .....	Replenish fluid and check for leaks (LO 10-3930-256-20).
Pedal improperly adjusted .....	Adjust linkage (para. 22).

(3) *Brake pedal under pressure gradually goes to floor plate.*

<i>Probable cause</i>	<i>Remedy</i>
Leaks in hydraulic brake system .....	Locate and eliminate leaks.
Scored master cylinder bore ..	.Install new master cylinder (TM 10-3930-256-20).

(4) *Brake pedal has springy or rubbery action.*

<i>Probable cause</i>	<i>Remedy</i>
Air in system .....	Bleed system (TM 10-3930-256-20).
Improper brake adjustment ..	Adjust brakes shoes (TM 10-3930-256-20).

(5) *Weak braking action.*

<i>Probable cause</i>	<i>Remedy</i>
Improperly adjusted brakes .....	Adjust brakes shoes (TM 10-3930-256-20).
Oil on linings.....	Replace lining (para. 20).
Incorrect lining .....	Replace lining (para. 20).

(6) *Heavy braking action.*

<i>Probable cause</i>	<i>Remedy</i>
Brake lining grease soaked .....	Replace lining (para. 20).
Brake shoes improperly adjusted .....	Adjust brake shoes (TM 10-3930-256-20).
Brake backing plate loose .....	Tighten or replace (TM 10-3930-256-20).

(7) *Brake releases slowly.*

<i>Probable cause</i>	<i>Remedy</i>
Hydraulic fluid congealed .....	Drain, flush and replace with proper brake fluid (LO 10-3930-256-20).
Retraction of brake shoes restricted by weak return .....	Clean, adjust or replace as necessary (para. 20).
springs, or dirt.	

(8) *Truck pulls to one side.*

<i>Probable cause</i>	<i>Remedy</i>
Improperly set brake shoes .....	Adjust brake shoes (TM 10-3930-256-20).
Brake linings grease soaked ..	Replace brake linings (para. 20).

c. Steering. Refer to paragraph 25 for steering gear troubleshooting.

d. Hydraulic.

(1) Lift carriage will not lift load.

*Probable cause*

Oil leaks In hoses .....

Defective pump .....

Fusetron blown .....

Defective valve .....

(2) Load creeps down from raised position.

*Probable cause*

Oil leak in lines .....

Leaky control valve .....

(3) Hoisting speed erratic.

*Probable cause*

Air in system .....

Low level in reservoir.....

(4) Control valve plungers will not return to neutral.

*Probable cause*

Sticking plungers .....

Broken springs or dirt lodged in seats .....

(5) Forks uneven when load is lifted.

*Probable cause*

Lift chains out of adjustment.....

(6) No motion of hydraulic unit when first started up.

*Probable cause*

Oil supply in tank too low.....

Oil viscosity too heavy.....

Air leak in pump inlet line.....

Restricted pump inlet line .....

Broken pump drive shaft, motor shaft or coupling.....

Pump completely worn out .....

Weak or broken relief valve spring .....

Relief valve plunger stuck by dirt or foreign matter .....

Pump rotating in wrong direction .....

Insufficient pressure to start load .....

Machine overloaded .....

Failure at control valve switch .....

(7) Loss of motion during operation.

*Probable cause*

Loss of oil supply due to broken pump inlet, outlet .....

or cylinder connecting lines or tank return line.

(8) Slow motion.

*Probable cause*

Pump wearing out.....

Pump rpm too slow.....

Failure in hydraulic lines.....

Relief valve plunger held partially off its seat by dirt.....

or foreign matter.

Badly scored relief valve plunger or seat.....

Weak relief valve spring .....

Aerated oil supply (foam in tank).....

Oil too thin .....

*Remedy*

Inspect fittings and couplings, tighten or replace as required (TM 10-3930-256-20).

Replace pump (TM 10-3930-256-20).

Replace (TM 10-3930-256-20),

Inspect plunger operation. Check pressure.

*Remedy*

Tighten fittings and couplings (TM 10-3930-256-20).

Tighten connections, replace valve if necessary (TM 10-3930-25620).

*Remedy*

Bleed air from system (para. 32).

Fill reservoir to prescribed level (LO 10-3930-256-20).

*Remedy*

Apply oil OE sparingly to plungers.

Replace or clean as necessary (para. 32).

*Remedy*

Adjust as necessary (TM 10-3930-256-20).

*Remedy*

Fill (LO 10-3930-256-20).

See lubrication chart (LO 10-3930-256-20).

Tighten hose (TM 10-3930-25620).

Repair or replace (TM 10-3930-256-20).

Repair or replace.

Replace pump (TM 10-3930-256-20).

Replace spring (para. 30).

Clean or replace (para. 30).

Check motor internal connections (para. 38).

Check pressure.

Reduce load.

Replace (TM 10-3930-256-20).

*Remedy*

Replace line (TM 10-3930-256-20).

*Remedy*

Replace (TM 10-3930-256-20).

Check pump motor, battery (para. 38, or TM 10-3930-256-10).

Replace lines (TM 10-3930-256-20).

Clean or replace (para. 30).

Replace valve (para. 30).

Replace (para. 30).

Change oil.

Check lube chart for proper grade (LO 10-3930-256-20).

<i>Probable cause</i>	<i>Remedy</i>
Oil supply too low.....	Fill reservoir.
Worn or scored piston packing.....	Look for dirt or chips in oil. Replace packing (para. 32).
ID of cylinder tube badly scored or nicked.....	Replace cylinder (para. 32).
Cylinder misalignment.....	Correct (TM 10-3930-256-20).
Linkage to valve plunger bent or out of adjustment,.....	Adjust.
thereby restricting length of travel of valve plunger to full open position.	
Mechanical obstruction of moving parts.....	Remove obstruction.
(9) <i>Jerky motion.</i>	
<i>Probable cause</i>	<i>Remedy</i>
Air in system .....	Bleed hydraulic system (para. 32e).
Cylinder misaligned due to structural warpage.....	Adjust.
(10) <i>Speed of operation slows down after usage.</i>	
<i>Probable cause</i>	<i>Remedy</i>
Pump worn Replace (TM 10-3930-256-20).	
Improper oil used in system .....	Check lube chart for proper grade (LO 10-3930-256-20).
Dirt or foreign matter in system .....	Drain, flush out system, replace with new oil.
(11) <i>Noisy operation.</i>	
<i>Probable cause</i>	<i>Remedy</i>
Air in hydraulic system.....	Bleed system (para. 32e).
Insufficient oil supply .....	Fill reservoir.
Pump worn out .....	Replace (TM 10-3930-256-20).
Air leak in pump intake line .....	Tighten hose (TM 10-3930-256-20).
Pump coupling worn.....	Replace.
Misalignment between motor shaft and pump drive.....	Align.
shaft.	
Vibration of pump lines.....	Secure lines.
Chattering relief valve. Weak relief valve spring .....	Replace.
Incorrectly set relief valve pressure.....	Reset.
Broken or cracked gears in pump .....	Replace pump (TM 10-3930-256-20).
(12) <i>Oil heats up rapidly.</i>	
<i>Probable cause</i>	<i>Remedy</i>
Pump slippage. Oil too thin.....	Check lube chart for proper grade.
Continued operation at relief valve pressure setting .....	Check operating procedures and load weights.
Operating pressure is close to relief valve pressure .....	Check operating procedures and load weights.
setting.	
Operating at excessively high pressure.....	Check pressure setting.
Dirty oil .....	Change oil.
Misalignment between pump drive shaft and motor.....	Align.
shaft.	
(13) <i>Hoist cylinder packing leaks.</i>	
<i>Probable cause</i>	<i>Remedy</i>
Packing worn.....	Tighten gland nut, replace packing (par. 32).
Piston scored.....	Replace cylinder (para. 32).
(14) <i>Hoist or tilt cylinder lowers or tilts while truck stands idle.</i>	
<i>Probable cause</i>	<i>Remedy</i>
Worn packing .....	Replace (para. 31 or 32).
Failure in hydraulic line.....	Check, tighten or replace (TM 10-3930-256-20).
Scored cylinder walls.....	Replace entire cylinder (TM 10-3930-25620 or para.
32).	
(15) <i>Reservoir flows over.</i>	
<i>Probable cause</i>	<i>Remedy</i>
Excess oil in reservoir .....	Check oil level plug with forks in lowered position and tilted back.

## Section II. ELECTRICAL SYSTEM

## 9. Horn Button Wiring

*a. Removal.*

- (1) Remove horn button assembly and steering wheel from steering gear (TM 10-3930-256-20). Dismount directional control switch from steering gear jacket (TM 10-3930-256-20) and tie it out of way.
- (2) Remove screws and covers (fig. 2) and disconnect external horn wires.
- (3) Loosen pinch bolt which clamps joint to shaft, enough to free shaft. Remove screws, and clamp which holds mast jacket to column, and lift jacket and shaft from truck.
- (4) With jacket and shaft assembly (fig. 3) on work bench, remove screws, and horn connector assemblies from mast jacket. Turn shaft to bring wires into view.
- (5) Unsolder horn button wires from contact assembly slip rings.

**Caution: Do not heat slip ring more than necessary to free wire.**

- (6) Solder length of replacement wire to end of each wire to be replaced, then pull wires out top end of shaft by pulling on attached contact.

**Caution: Don't pull free end of wires into shaft.**

- (7) Unsolder contact from old wires.

*b. Installation.*

- (1) Install contact on new wires. Solder lower end of new wires to slip rings, at recesses from which old wires were removed.

**Caution: Location of new wire on slip ring must not interfere with slid-**

**ing contact of horn connector. Remove all excess solder from slip rings.**

- (2) Reverse a(4) through b(1) above to install.

## 10. Wiring, Head-, Tail- and Stop Lights

*a. Headlight Wiring Removal.*

- (1) Remove floor plate and cowl (TM 10-3930-256-20).
- (2) Dismount headlight and detach flexible conduit from outer upright and truck frame (TM 10-3930-256-20). Remove clamps as necessary to free conduit and wiring.
- (3) Remove screws, and remove front cover of electrical equipment box (fig.4). Disconnect both wires numbered 5 at fuse holder (fig. 5).
- (4) Remove instrument housing from steering column (TM 10-3930-256-20). Remove lead number 34 at light switch on instrument housing. Remove headlight and wiring from truck.

*b. Headlight Wiring Installation.* Reverse *a* above.

*c. Tail- and Stop Light Wiring Removal.*

- (1) Remove tail- and stop light assembly (TM 10-3930-256-20).
- (2) Remove truck floor plate and cowl (TM 10-3930-256-20). Remove cover of electrical equipment box a(3) above.
- (3) Disconnect wires numbered 5 and 33 at taillight terminal board (fig. 4). Disconnect wires number 5 at fuse holder (fig. 5) and wire number 33 at taillight resistor. Remove conduit box connectors (fig. 4) from conduit at each end of conduit, and remove harness from truck.

*d. Tail- and Stoplight Wiring Installation.*

Reverse *c* above.

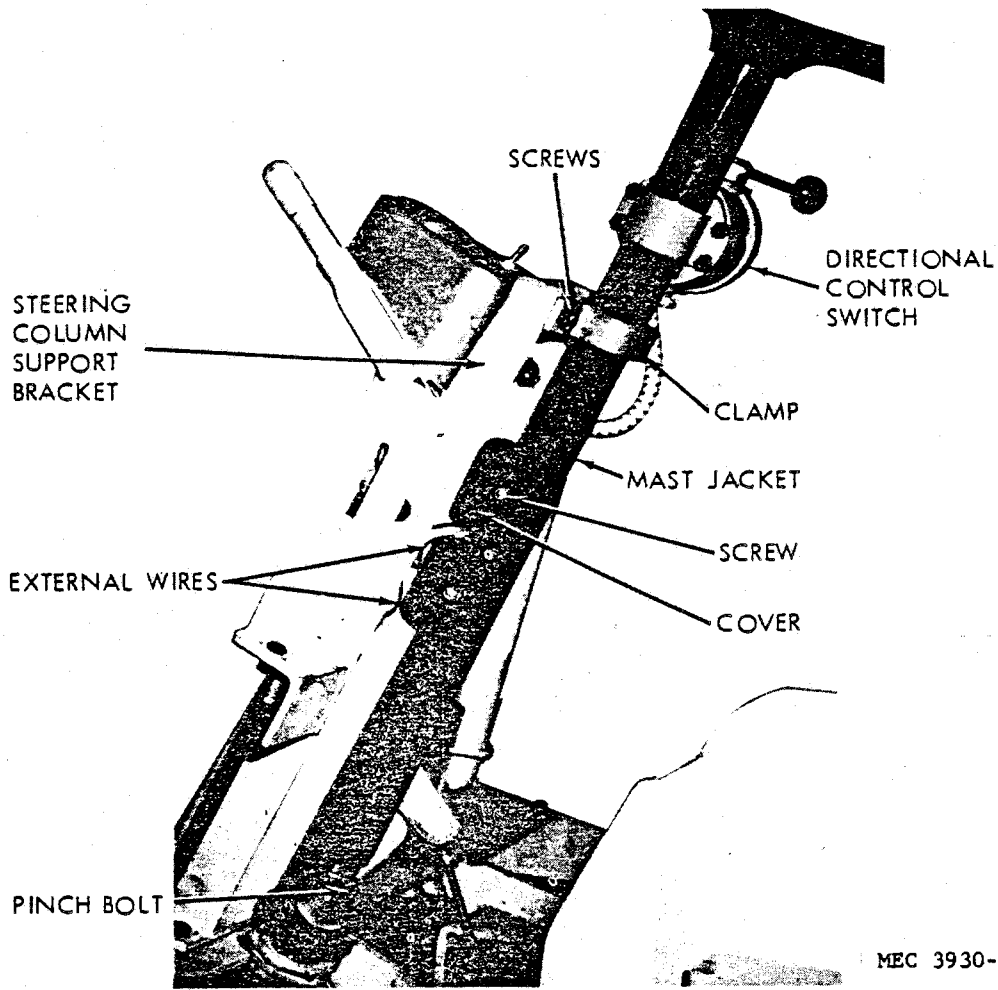

MEC 3930-256-35/2

*Figure 2. Steering column removal.*

*Figure 2. Steering column removal.*

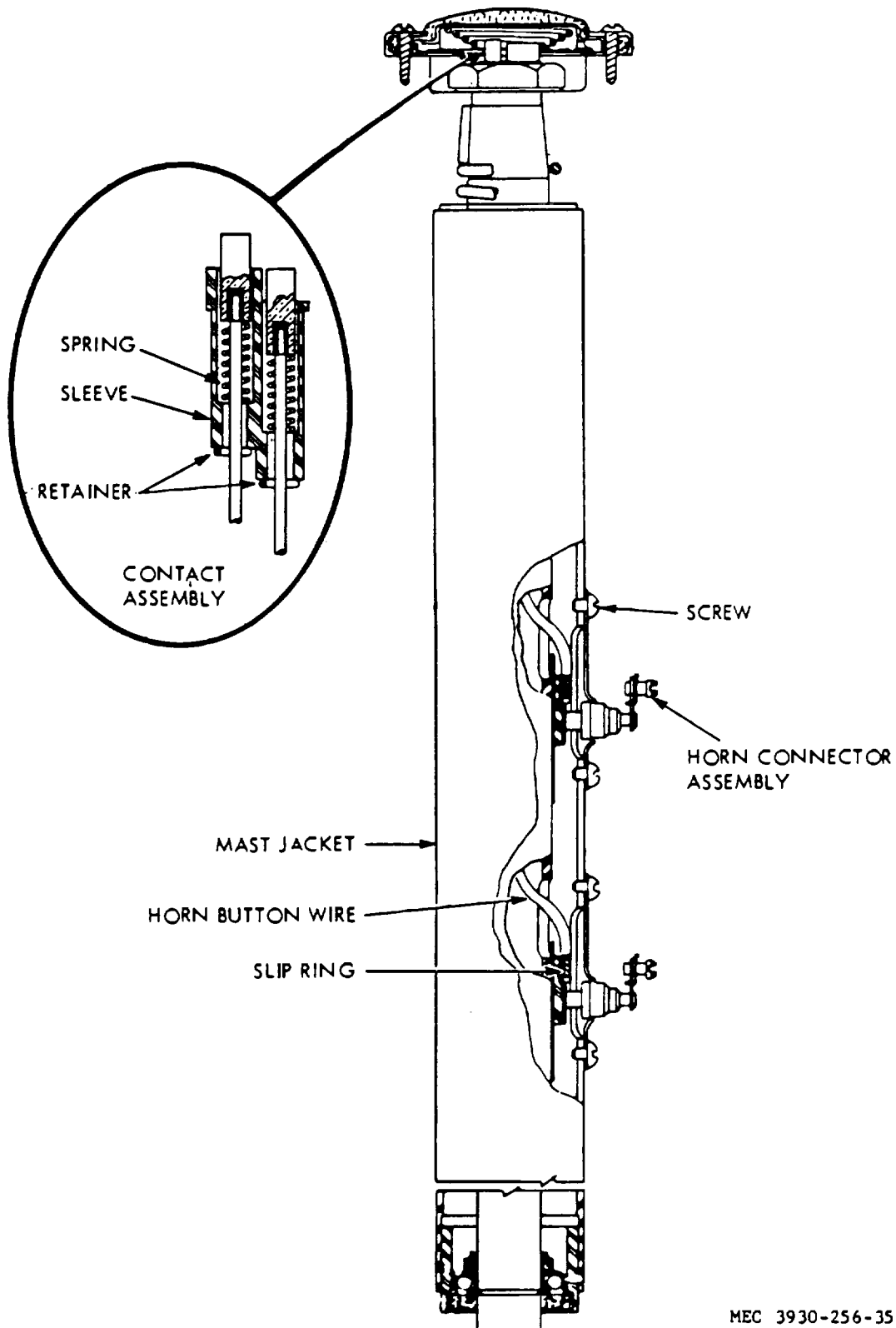

MEC 3930-256-35/3

Figure 3. Horn button wire replacement.

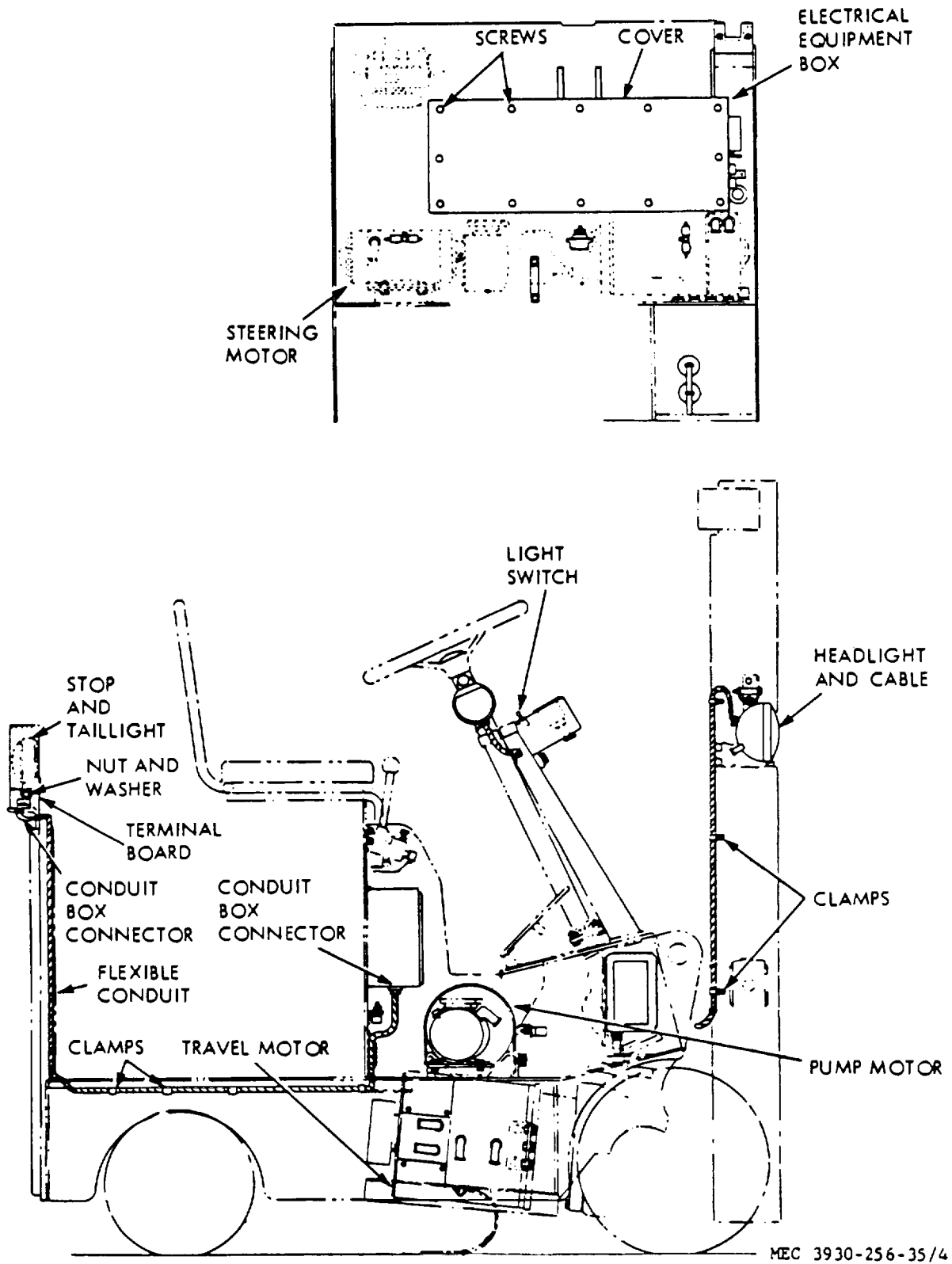
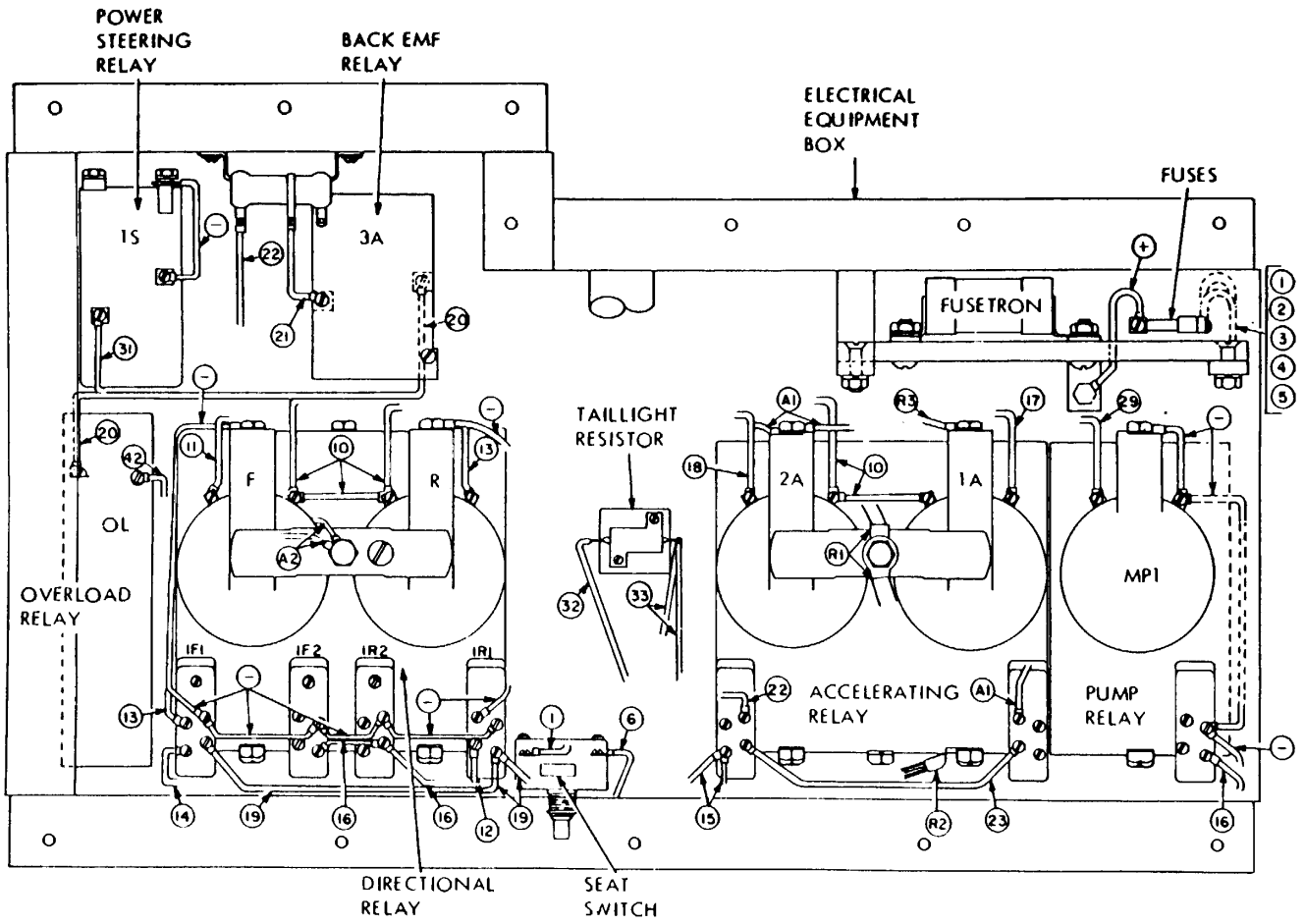

Figure 4. Electrical system arrangement.



MEC 39 30-256-35/5

Figure 5. Electrical equipment box.

AGO 8176A



## 11. General

This section contains direct and general support maintenance instructions for the power axle, and the mechanical adapter and coupling through which the travel motor drives the axle. Because of the close mechanical and functional relationship of the axle, adapter, and coupling, service of these assemblies will be grouped in the order in which they are encountered, in servicing the power axle, as though all were axle components. Periodic overhaul of the entire axle assembly is not anticipated. Rather, service will generally be required either at those elements of the axle outboard of the differential assembly, or to the differential assembly itself. The following instructions treat each of these areas separately.

## 12. Power Axle Ends

### a. Removal and Disassembly.

- (1) Raise vehicle to convenient working height and remove front wheels (TM 103930-256-20).
- (2) Disconnect brake lines and remove fittings (fig. 6).
- (3) Drain axle lubricant (LO 10-3930-25620).
- (4) Remove nuts, washers and tapered bushings holding final drive gear case (fig. 7) to axle housing. Tap studs as necessary to separate, and remove gear case with attached parts. Axle will stay in housing. Note. The axle housing is seldom of maintenance significance; if necessary to service it, refer to paragraph 13.
- (5) Remove and discard gasket. Remove bolts, washers, and axle shaft bearing retainer, then pull out axle shaft and ball bearing. Take retaining collar from within axle housing. If to be serviced, press bearing from axle shaft.
- (6) Take cotter pin, nut and washer from end of final drive gearshaft, and remove final drive gear, final drive gearshaft, bearing cups and cones, and rollers from gear case.

AGO 8176A

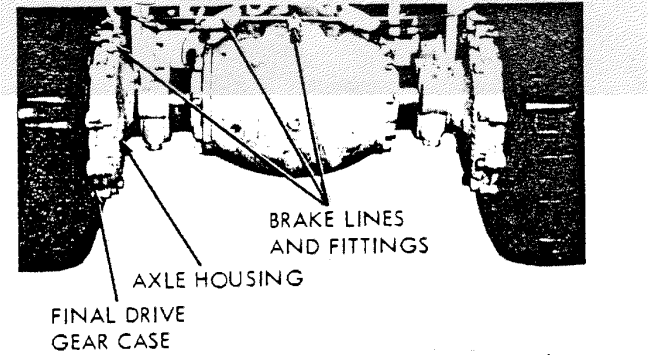

MEC 3930-256-35/6

Figure 6. Power axle, front view

- (7) Remove screws and nuts to wheel adapter, and separate gearshaft, adapter, oil seals and washer. Remove wheel bolts, and remove brake drum.

### b. Inspection.

- (1) Check oil seals for any imperfection.
- (2) Examine bearing rollers, cups and cones for wear. Replace as a set, if any element is worn, ridged or pitted.
- (3) Inspect final drive gear and axle shaft pinion for chipping, cracks, or scoring.

### c. Assembly and Installation. Assemble by reversing b above, noting the following:

- (1) Coat wheel bearings and oil seals with GAA before assembly.
- (2) After gear, washer, and nut have been installed on final drive shaft, tighten nut until slight drag is felt when turning case. This is wheel bearing adjustment, with correct final result of no endplay but slight bearing drag. If cotter pin will not enter hole with this adjustment, stake nut into spline slot on shaft. After installation bleed brake hydraulic system (TM 10-3930-256-20).

## 13. Power Axle Assembly, Complete

- a. Removal (Axle, Adapter, and Motor).
  - (1) Remove entire mast assembly, includ-

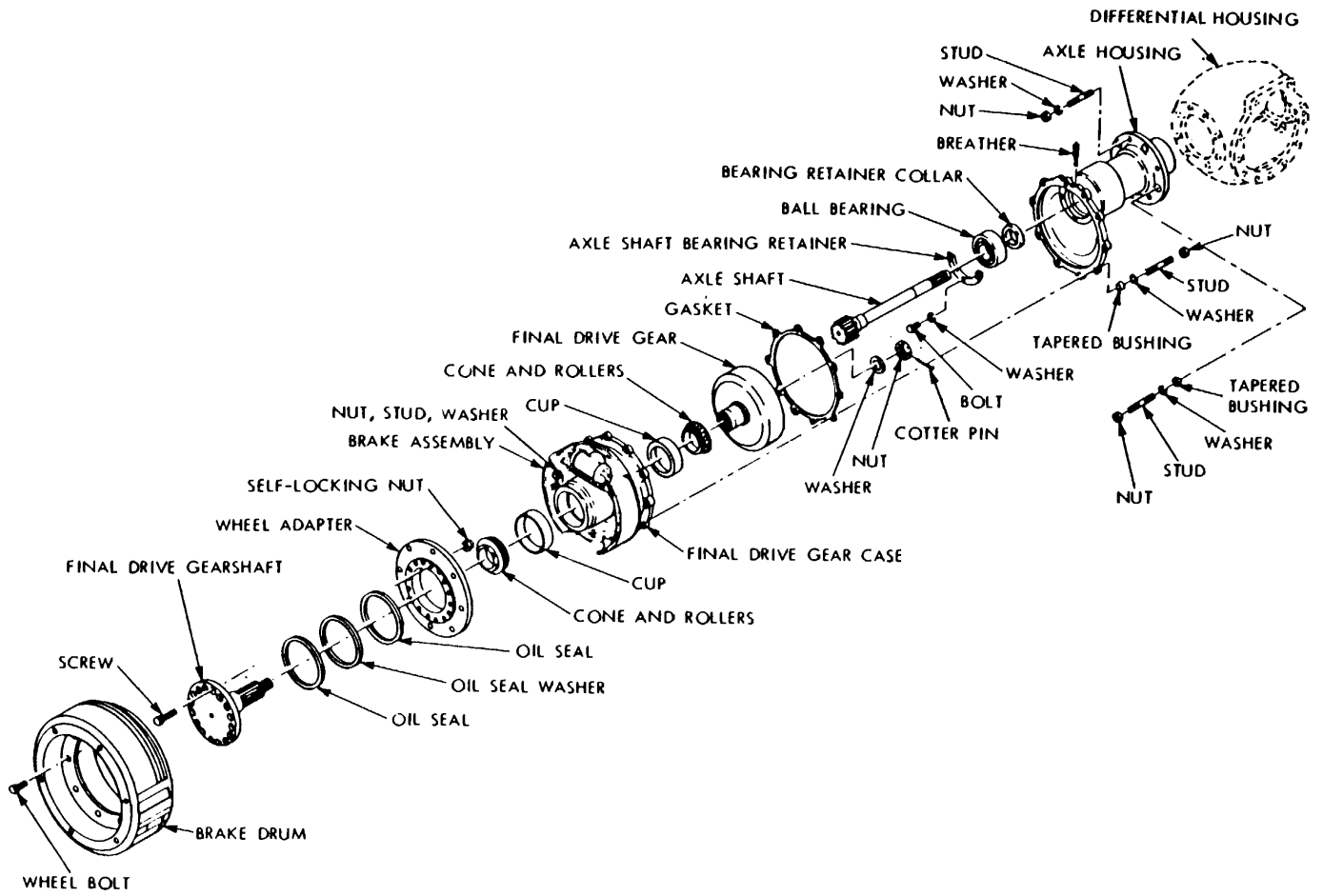

MEI: 3930-256-35/7

Figure 7. Power end axle, exploded view.

ing carriage, forks, and lift cylinder as a unit, as follows:

- (a) Attach a chain hoist to mast assembly (or use the forks of another fork lift truck), and relieve the weight of the assembly on its supporting parts. Arrange to brace the assembly against tipping as disconnections are made.

Caution: The forks are to be fully lowered before disconnecting any hydraulic lines, to avoid sudden lowering of lift carriage when trapped hydraulic oil is released.

- (b) Remove forks, load backrest, and headlight assembly from mast column (TM 10-3930-256-20).

- (c) Disconnect both tilt cylinder assemblies at uprights (TM 10-3930-256-20).

- (d) Disconnect hydraulic hose at lift cylinder fitting (TM 10-3930-256-20), and cap hose to prevent entry of dirt.

- (e) Remove capscrews, washers and angle brackets which secure outer uprights to bearing bracket on frame (fig. 8, view A). Lift mast assembly from truck.

- (2) Disconnect and remove brake lines and fittings (fig. 6). Protect lines against kinking or entry of dirt while disconnected.

- (3) Remove floor plate and remove thermal relay from travel motor. Disconnect seat and hand brake linkage from brake on rear of motor (TM 10-3930-256-20). Drain lubricant from axle (LO 103930-256-20).

- (4) Remove screws and washers attaching guard (fig. 9, view A) to underside of truck. Remove guard and static drag straps. Remove nuts and washers attaching motor fan shield to truck and remove shield.

- (5) Support motor from below with wheeled dolly or floor jack. Disconnect and tag leads to travel motor (fig. 9, view B).

Note. Two crossed field jumper leads need not be removed. Remove nuts, screws, and

- washers attaching adapter to mounting brackets on truck frame.
- (6) Remove screws, nuts, washers, and bearing brackets (fig. 9, view B) securing axle to truck. Lift front end of truck from axle, and draw axle,

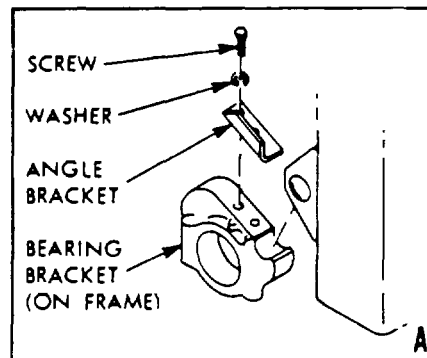
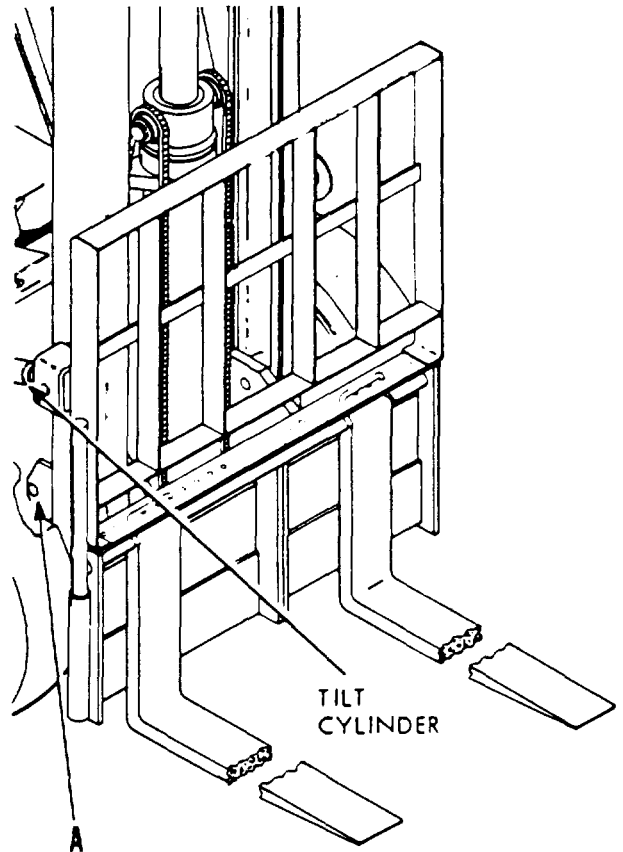

MEC 3930-256-35/8

Figure 8. Mast assembly removal.

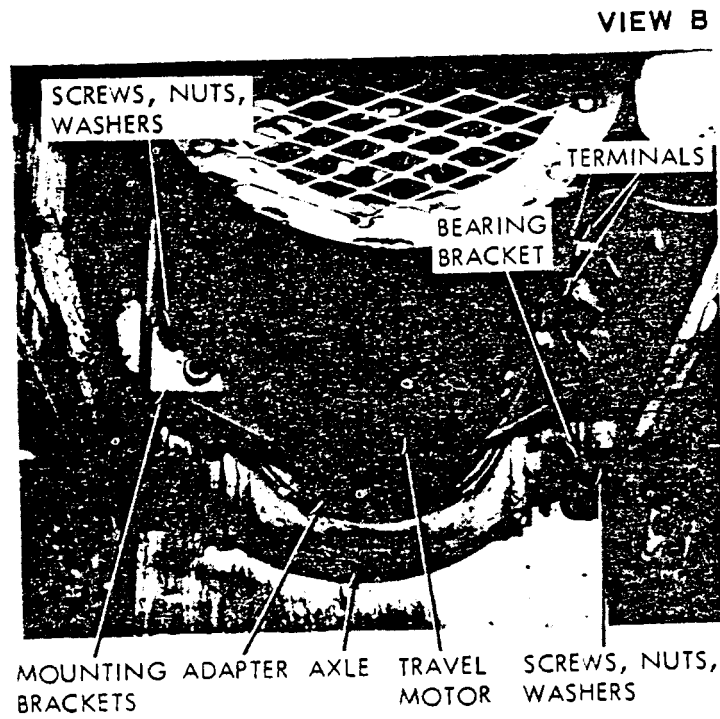
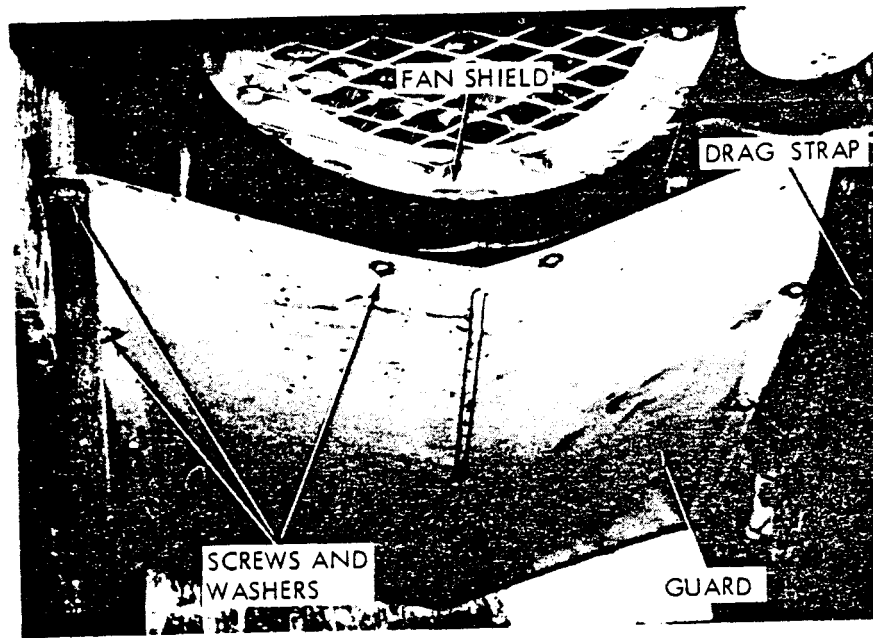

Figure 9. Power axle removal, bottom view

adapter, and travel motor as a unit from under truck.

(7) Remove screws and washers, and nuts attaching adapter to axle and take motor and adapter, as a unit, from axle. Remove gaskets which were used between adapter and axle. Make a written note of total thickness of these gaskets, to determine approximate thickness of gaskets to use at reassembly.

(8) Remove screws and washers attaching adapter to motor and draw motor

from adapter. Coupling will now separate, part staying with motor, part with adapter.

*b. Disassembly of Power Axle.*

(1) Remove nuts, washers, and tapered bushings from studs (fig. 7) attaching axle and differential housings. Tap parts with a soft mallet if necessary to free bushings from grip on studs, for disassembly. Studs may be left in place, if not to be serviced.

(2) Remove gaskets from studs and measure the thickness removed from each

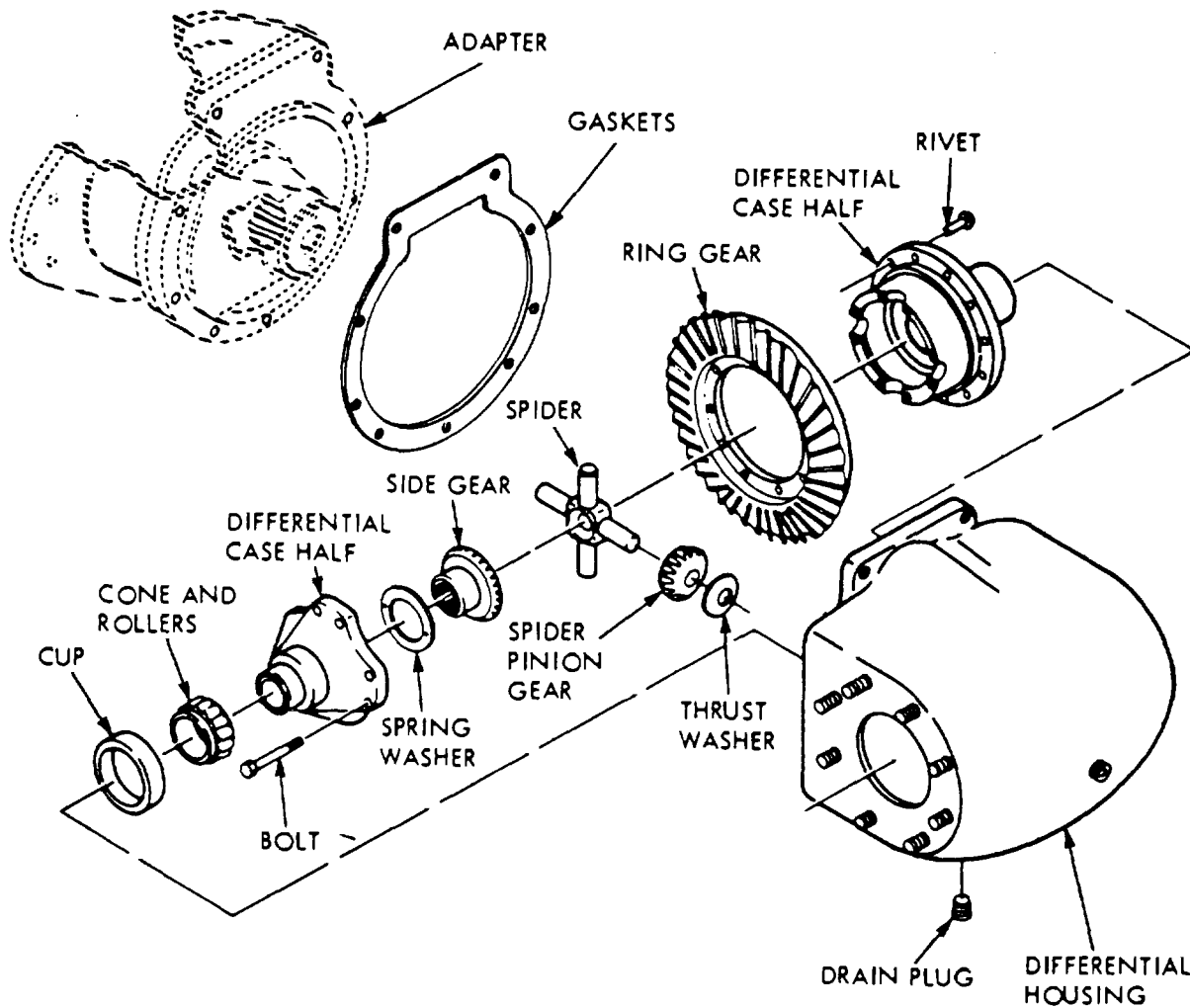

MEC 3930-256-35/10

Figure 10. Differential, exploded view,

side. If no new parts are needed in the differential, the same thickness of new gaskets can be installed at assembly. This will eliminate the need for certain ring and pinion adjustments. Take differential bearing cup (fig. 10) from bore of axle housing, and keep it with cone and rollers with which it was used.

- (3) Take remainder of differential assembly from housing. Pull differential side bearing cone and rollers from differential case halves, if they are to be replaced.
- (4) Remove screws holding differential case halves together and separate case halves. Remove spider, gears, spring washers and thrust washers.
- (5) If necessary to replace ring gear, center punch each rivet, drill a pilot hole through, and drill off head of rivet from bevel end. Punch out rivet.

Note. Ring gear and pinion must both be replaced as a set, if one is defective.

*c. Inspection.*

- (1) Inspect gears for wear or damage.
- (2) Inspect for pitted, scored, or worn thrust faces of case halves, thrust washers, spider trunnions.
- (3) Inspect spider trunnions also for looseness in differential case bores. Check for free rotation of bevel gears on spider trunnions.

*d. Assembly.* Assembly of the differential and power axle is essentially the reverse of the disassembly procedure in *b* above, for sequence in which parts are installed. However, in the course of assembly, various checks and adjustments are to be made. Assemble by reversing the procedure in *b* above as appropriate, and incorporate the checks and adjustments in *e* below in the assembly procedure.

Note. At assembly, use arbor press where necessary. Install all new seals and gaskets. Replace ring gear and pinion as a set, if either is to be replaced. Replace thrust washers only in complete sets.

*e. Adjustment.* Three basic adjustments are to be made when differential has been reassembled after replacement of parts. These are the differential bearing preload adjustment (to be

made first), drive gear and pinion backlash adjustment, and tooth contact adjustment.

Note. The latter two adjustments are so related that a change in either one causes a change of the other adjustment.

- (1) Adjust differential bearing preload to be between 0.005 inch and 0.008 inch as follows:

(a) With bearing cones in place, install both axle housings (fig. 7) to differential housing, with differential assembly installed, with same thickness of gaskets at each side as was removed at disassembly. If new parts have been installed, use about 0.030 inch total gaskets at each side initially.

(b) Turn drive gear by hand, testing for noticeable drag due to preload condition of bearings. If no drag exists, reverse step (a) above, remove gaskets, and repeat test until drag is noticed. Gaskets 0.005 inch thick and 0.0075 inch thick are used. Decrease total gasket thickness in 0.0025 inch steps by removing two 0.005 inch gaskets and adding one 0.0075 inch gasket.

(c) If drag is noticeable on first trial, reverse procedure for decreasing gasket thickness in (b) above until no drag is present, then decrease total gasket thickness until drag is felt. Preload will now be between 0.000 inch and 0.003 inch. Decrease total gasket thickness used by 0.005 inch to obtain 0.005 to 0.008 inch preload. (2) Check pinion and ring gear backlash adjustment as follows:

- (2) Check pinion and ring gear backlash adjustment as follows:

(a) Install adapter-to-axle gaskets and install adapter assembly to assembled axle (fig. 10).

(b) Remove drain plug from differential housing. Install plug (3/4-14 PT threads) with slightly longer each than original plug, to contact and lock ring gear from rotation.

(c) Install a dial indicator on adapter flange, to take a reading at a point 1.10 inches from the center of the

coupling half. Rotate coupling half through freedom permitted by pinion and ring gear backlash. Reading is to be 0.005 inch to 0.015 inch. Adjustment to correct is given in (3) below.

- (3) Determine, and adjust ring gear and pinion relationship, *after* performing (1) and (2) above, as follows:

Note. Several adjustments of both pinion and ring gear setting may be necessary in the following procedure before correct adjustment is achieved. It is not possible to specify the exact thickness of gaskets to be added, removed, or exchanged at any stage. This must be determined by trial and error.

(a) Remove adapter assembly (fig. 10) from axle. Apply a thin coating of red lead to drive face of ring gear teeth, and reinstall adapter to axle, adding gaskets (fig. 10) to increase backlash, or using fewer gaskets to decrease backlash.

(b) Engage adapter coupling half with a pry bar, and turn it until drive wheels have made one revolution in the forward direction.

(c) Remove adapter assembly from axle. Examine teeth of ring gear, and compare marks in red lead from pinion gear contact with example shown in fig. 11.

Note. Ring gear is on left side of pinion when installed. References to follow will be on this basis.

(d) If marks in red lead compare with those shown in view A or C, figure 11, indicating high, narrow tooth contact (pinion too far out), adjust by removing one or more adapter-to-differential housing gaskets (fig.10) to move pinion in direction indicated in view A, and transfer one or more axle housing-to-differential housing gaskets (fig. 9) from left side of differential housing to right side. Repeat (a) through (c) above to check results of adjustment.

Note. Do not change them from one side to the other as needed, so differential bearing preload will not be changed.

(e) If marks in red lead compare with those in view B or D, figure 11,

reverse adjustment procedure given in (d) above, and repeat (a) through (c) above to check results of adjustment.

f. *Installation.* At this time the axle adapter will be installed on axle. Reverse a above, modifying instructions as needed to secure adapter to truck.

#### 14. Drive Gear

a. *Removal.*

(1) Remove differential and drive gear (para. 13b).

(2) Disassemble differential (para. 13b).

(3) Carefully center punch rivets in center of head (fig. 12).

(4) Use drill /32 inch smaller than body of rivet to drill through head.

(5) Press out rivets and remove gear from case.

B *Installation.* Rivet drive gear to case, and reverse a(1) and (2) above.

#### 15. Drive Axle Adapter (Including Coupling)

a. *Removal.* Refer to para. 13a for removal of adapter as part of axle maintenance. If only adapter is to be serviced, remove as follows:

(1) Remove truck floor plate, and travel motor thermal relay. Disconnect brake rod and cable at brake on rear of motor (TM 10-3930-256-20).

(2) Perform para. 13a(4), (6), (7).

b. *Disassembly.*

(1) Remove screws, nuts, and washers (fig. 13) holding bearing cage to adapter housing. Remove housing and gasket.

(2) Free retaining ring holding collar, slide collar down, and remove cushions and sleeve on axle side coupling. Remove sleeve from motor side coupling and any cushions that may have remained with motor when separated.

(3) Remove cotter pin and nut from pinion. Take coupling half from pinion, and remove collar and retaining ring.

(4) Remove screws and washers. Remove

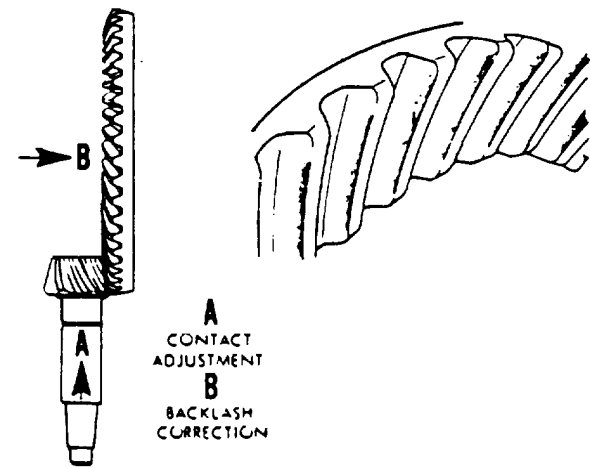

**VIEW A**  
**HIGH NARROW TOOTH CONTACT**  
 (PINION TOO FAR OUT)

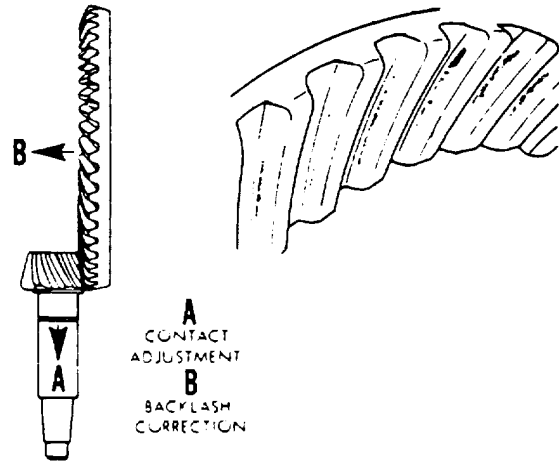

**VIEW B**  
**LOW NARROW TOOTH CONTACT**  
 (PINION TOO DEEP)

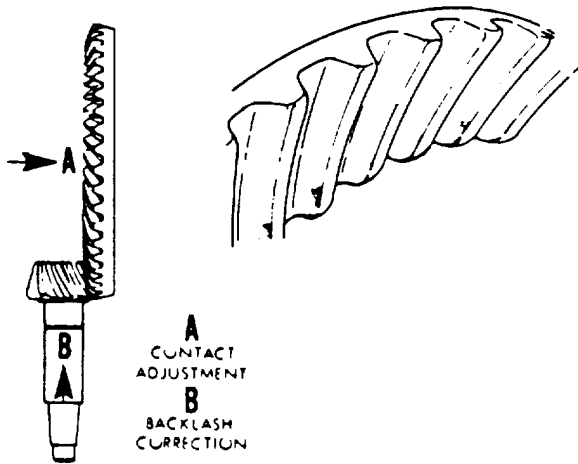

**VIEW C**  
**SHORT TOE CONTACT**  
 (DRIVE GEAR TOO CLOSE TO PINION)

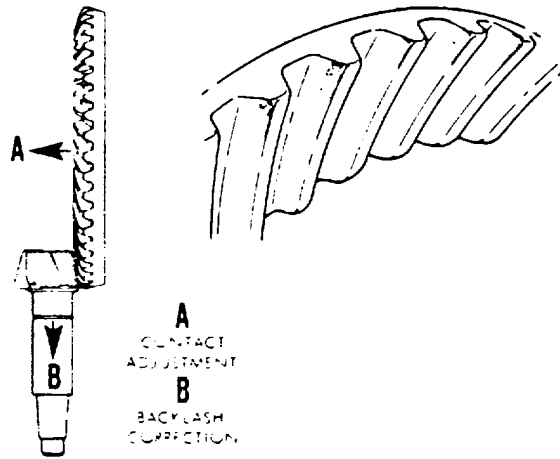

**VIEW D**  
**SHORT HEEL CONTACT**  
 (DRIVE GEAR TOO FAR FROM PINION)

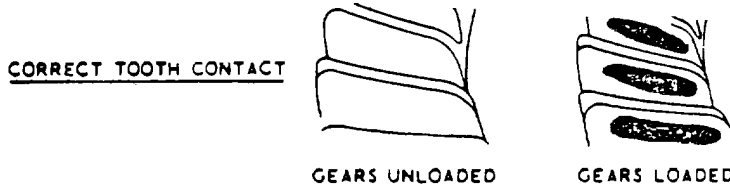

CORRECT TOOTH CONTACT

GEARS UNLOADED

GEARS LOADED

MEC 3930-256-35/11

Figure 11. Ring and pinion gear tooth contact indications.



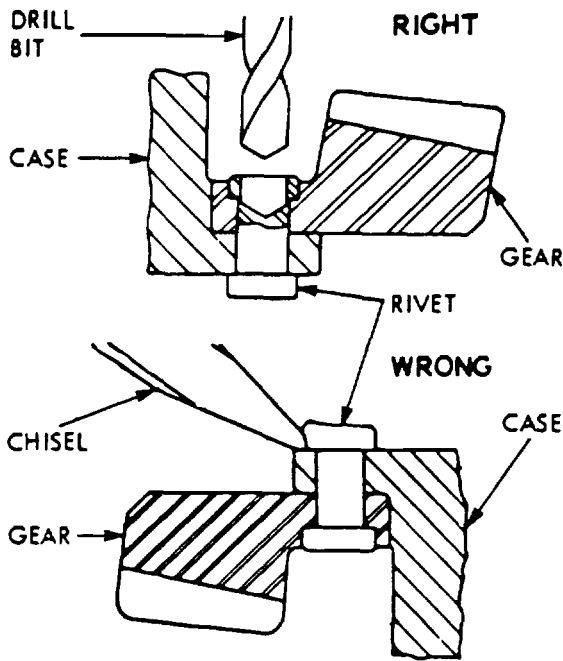

MEC 3930-256-35/12

Figure 12. Removing drive gear rivets.

oil seal, retainer, thrust washer, spacers and gaskets from cage.

- (5) Remove double row roller bearing from cage. Remove retaining ring, and take pinion with race and retain-

ing ring from cage. Take single row bearing from cage.

*c. Cleaning, Inspection and Repair.*

- (1) Clean all metal parts in SD. Coat parts liberally with GO gear oil.
- (2) Inspect pinion for wear or damage. Check bearing condition, and fit on shaft and in bearing cage.
- (3) Replace all nonmetal parts, and unserviceable metal parts at assembly.

*d. Assembly.*

- (1) Reverse b(5) through c(3) above.

Note. Install collar and ring before installing axle side coupling half. Install square bored coupling half on motor.

- (2) Install one sleeve in each coupling half. Place all cushions in the axle side coupling half where they will be retained by the collar and sleeve, so each cushion is snugly against the adjacent finger of axle side coupling half. Space between cushions is to be entered by fingers of motor coupling half on assembly.
- (3) Lubricate cushions, and fingers of motor side coupling half, with OE engine oil. Carefully enter fingers of motor side coupling half between cushions while assembling motor to adapter assembly. Install screws, nuts, and washers to secure motor to adapter assembly.

*e. Installation.* Reverse a above.

**Section IV. REAR AXLE**

**16. Steering Axle**

*a. Removal.*

- (1) Jack or hoist truck high enough to provide enough space in which to work. Block truck so it cannot fall after being raised. Remove wheel and tire assemblies (TM 10-3930-256-20).
- (2) Disconnect drag link (fig. 14) from steering axle bell crank.
- (3) If rear axle is raised from ground, support it against falling when attaching parts are removed. Remove

four screws and washers, and retainer bar at front of axle.

- (4) Lower axle, or raise truck, to get clearance and roll axle from beneath truck. Take axle blocks from axle.

*b. Disassembly.*

- (1) Remove nuts and cotter pins (fig. 14) which hold tie rods to bell crank and to steering knuckles. Remove tie rods.

Note. If necessary to free tie rod ends from knuckles or bell crank, tap with a soft mallet or use a puller that will not change threads.

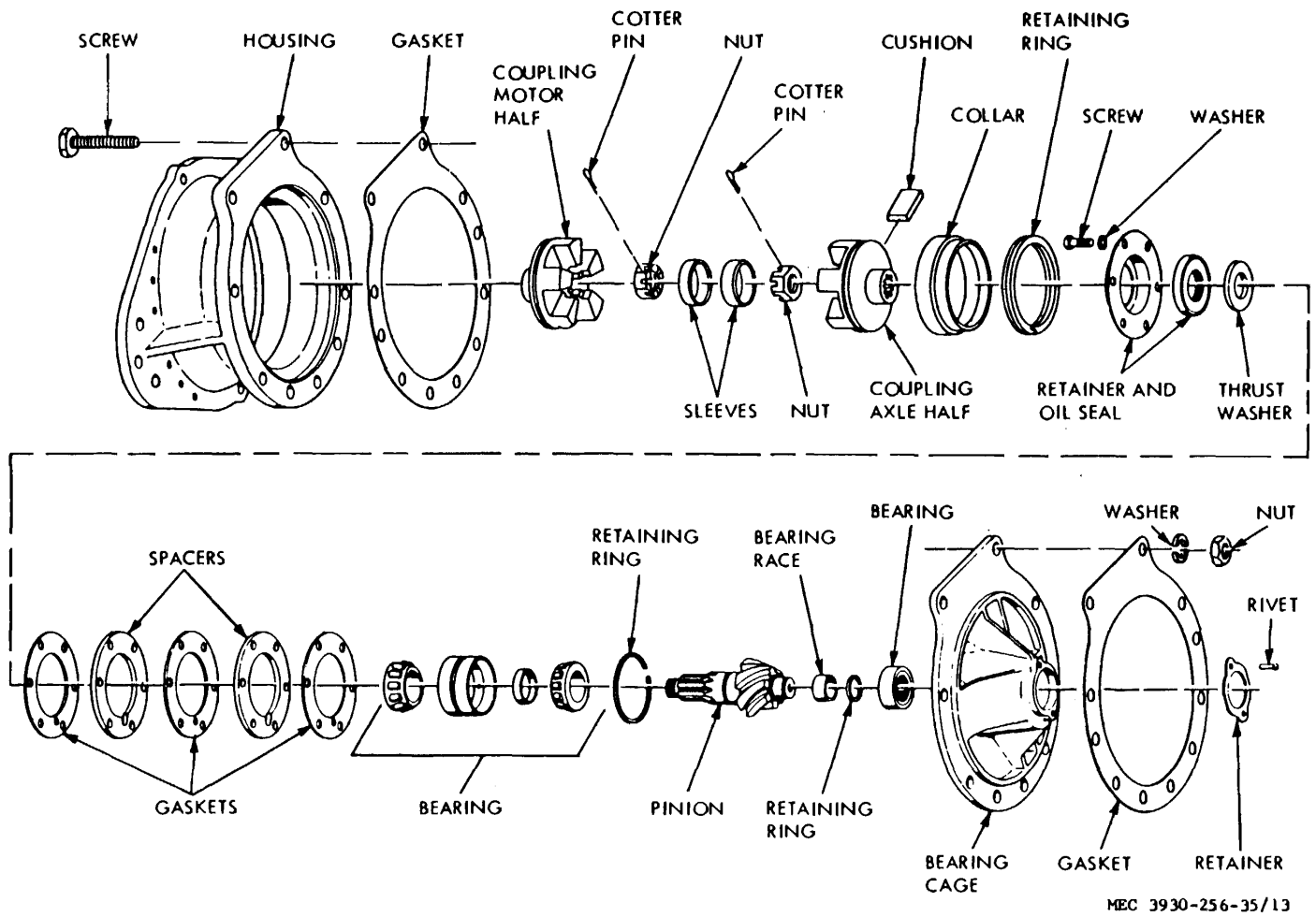
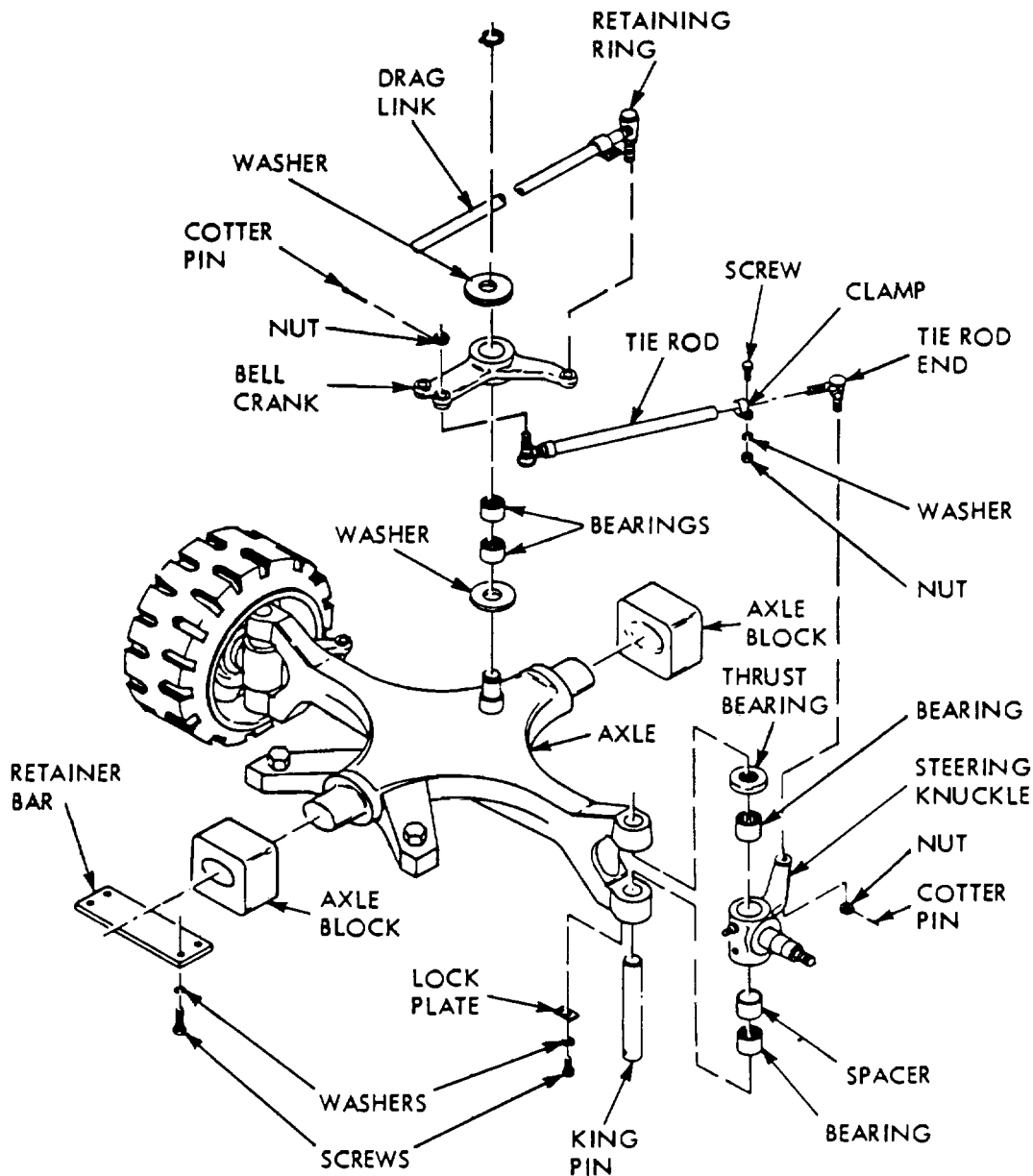

Figure 13. Adapter and coupling, exploded view

AGO 8176A



MEC 3930-256-35 / 14

Figure 14. Steering axle, exploded view.

- (2) Remove tie rod ends by loosening nut and screw through clamp, and unscrewing end from tie rod.

Note. One end of each tie rod bears left hand threads.

- (3) Take off bell crank retaining ring, and remove bell crank and both washers and bell crank bearings.

- (4) Remove king pin lock plate screws, washers, and lock plate. Press out king pin, remove steering knuckle, bearings, and spacer.

*c. Cleaning, Inspection and Repair.*

- (1) Clean all parts in SD.
- (2) Inspect threaded parts for damage.

Inspect all bearings for wear. If practicable, repair damaged threads with a tap or thread chaser. Replace all unserviceable parts at assembly.

d. *Lubrication and Assembly.*

- (1) Pack all bearings with grease, GAA.
- (2) Reverse procedure in b above.

- e. Installation. Reverse procedure in a above.
- f. Adjustment. Adjust tie rods (TM 10-3930-256-20).

**17. Steering Knuckles, Pins and Bearings**

Refer to paragraph 16 for removal and installation of steering knuckles, pins and bearings.

**Section V. BRAKES**

**18. General**

This section covers direct and general support maintenance of the service (wheel) brake system.

**19. Parking Brake System**

Maintenance of the parking brake system is covered in TM 10-3930-256-20.

**20. Brake Assembly**

a. *Removal.*

- (1) Perform paragraph 12a, less step (5), to get access to brake assembly.
- (2) Hold antirattle pin (fig. 15) with fingertip from behind backing plate, press outer spring retainer in, to compress spring, turn retainer a quarter turn either way and remove spring, both retainers, and pin. Repeat at other brake shoe.
- (3) With brake spring pliers, remove shoe return spring, retaining spring and both brake shoes.
- (4) Remove screws and washers and remove wheel cylinder.

b. *Wheel Cylinder Repair.*

- (1) Remove cylinder by performing a above.
- (2) Remove boots and push rods (fig. 15) from cylinder.
- (3) Remove spring, pistons and cups.
- (4) Inspect bore of cylinder, and pistons for pits or scoring. Hone cylinder bore clean if minor pits are present. If bore cannot be cleaned up readily,

install complete new cylinder assembly.

- (5) Clean all metal parts in alcohol, dry thoroughly, and install cylinder repair kit. Assemble by reversing a(3), to b(1) above.

c. *Cleaning* (Except wheel cylinder).

- (1) Remove dust from assembly with compressed air and stiff bristle brush.
- (2) If brake fluid has leaked onto assembly, replace brake linings (d below), and wash off fluid with alcohol.
- (3) If axle lubricant has leaked onto assembly, replace oil seal (fig. 7), per paragraph 13, replace brake linings, and clean parts with SD.

**Caution: Do not get SD on any rubber brake parts. It will cause them to swell and rot.**

d. *Brake Shoe Repair.* Install new bonded lining on brake shoes, when less than 1/4 inch of lining remains, at thinnest point. Apply lining in accordance with good practice, and instructions for use of equipment available.

e. *Installation.* Reverse a above. Adjust brake lining clearance and bleed air from brakes (TM 10-3930-256-20).

**21. Brake Master Cylinder**

a. *Removal.* Refer to TM 10-3930-256-20.

b. *Disassembly.*

- (1) Remove push rod and bellows (fig. 16).
- (2) Remove retaining ring from cylinder. Take out piston stop, piston, primary cup, spring and check valve.

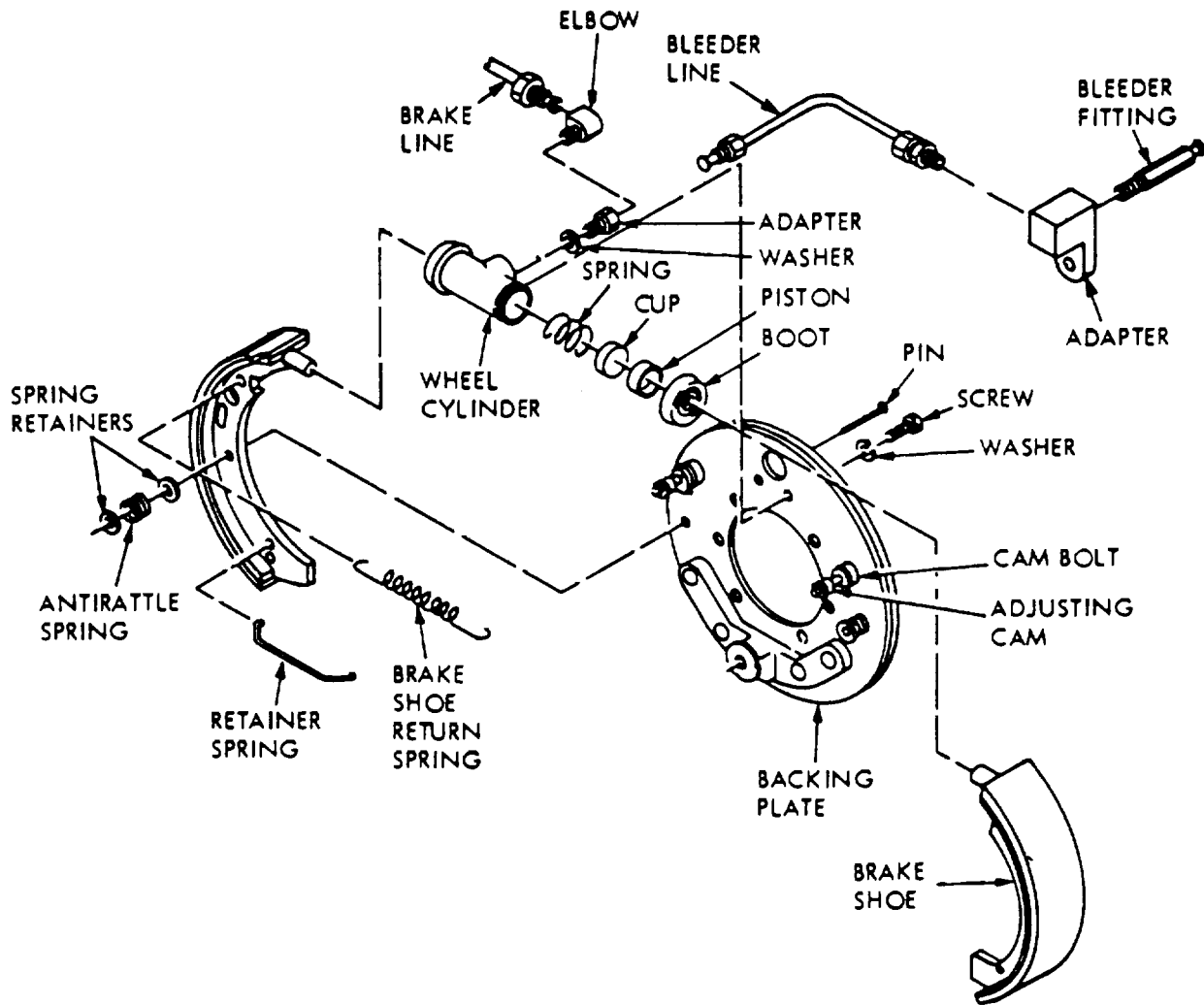

MEC 3930-256-35/15

Figure 15. Service brake, exploded view

- c. *Cleaning.* Clean all reusable parts with denatured alcohol. Flush reservoir section thoroughly, and be sure fluid passages are open.
- d. *Inspection.* Inspect bore of cylinder for any surface roughness, particularly in the area of piston and cup travel.
- e. *Repair.* Hone minor surface irregularities from cylinder bore.
- f. *Assembly and Installation.* Reverse a and b above, installing all parts from repair kit

AGO ST17A

listed in TM 10-3930256-35P. After installation, adjust pedal travel as given in paragraph 22 below.

## 22. Brake Pedal and Linkage

### a. Removal.

- (1) Remove floor plate from truck (TM 10-3930-25620).
- (2) Remove cotterpin and clevis pin (fig.17) from brake rod. Loosen jam nut

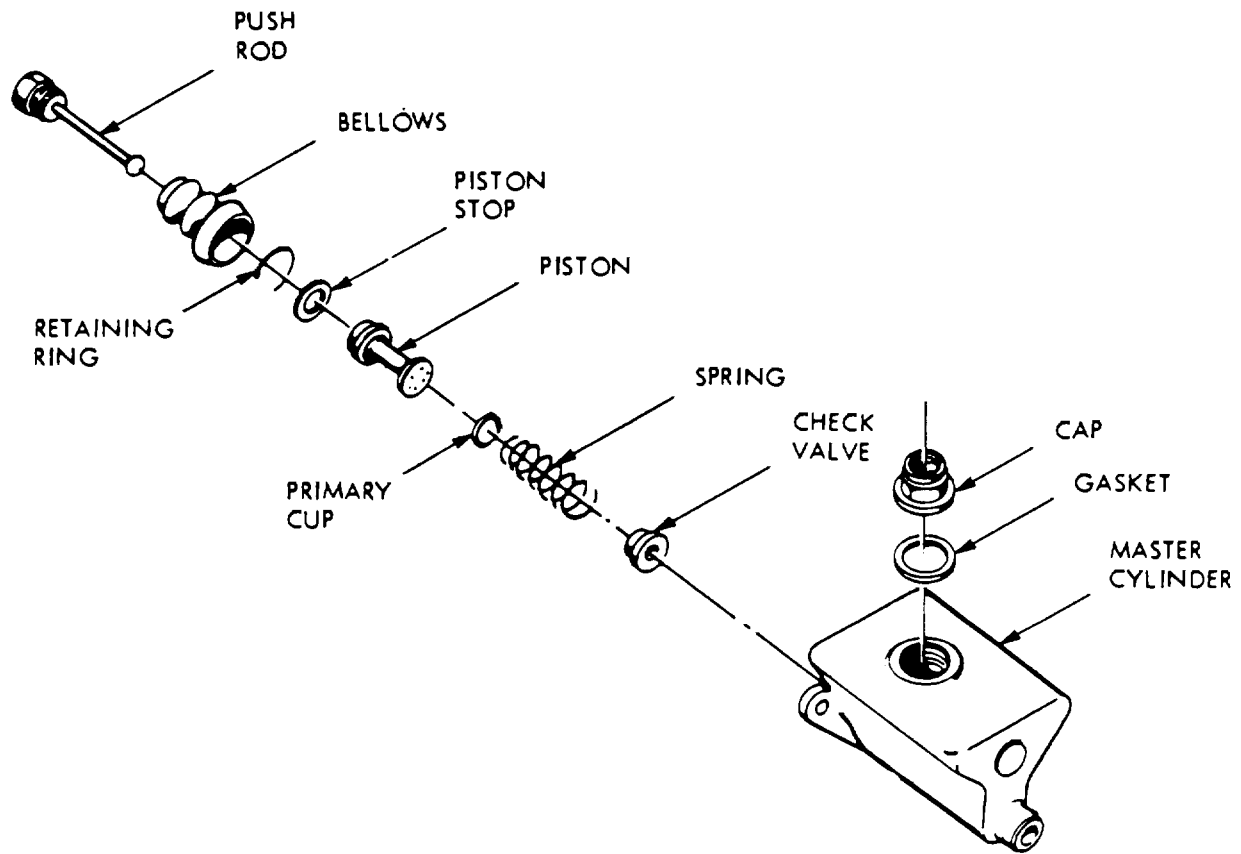

MEC 3930-256-35/16

Figure 16. Brake master cylinder, exploded view

and unscrew brake rod from master cylinder push rod.

(3) Remove screws, nuts, and washers attaching shaft, lift entire assembly free of truck.

b. Installation and Adjustment.

- (1) Reverse a above.
- (2) Bleed brakes and adjust lining clearance (TM 10-3930-256-20).
- (3) Adjust pedal free travel to 1/4 inch to 5/8 inch by turning master cylinder push rod (fig. 16) on threads of brake rod (fig. 17). Tighten jam nut to brake rod to secure adjustment.

AGO 8176A

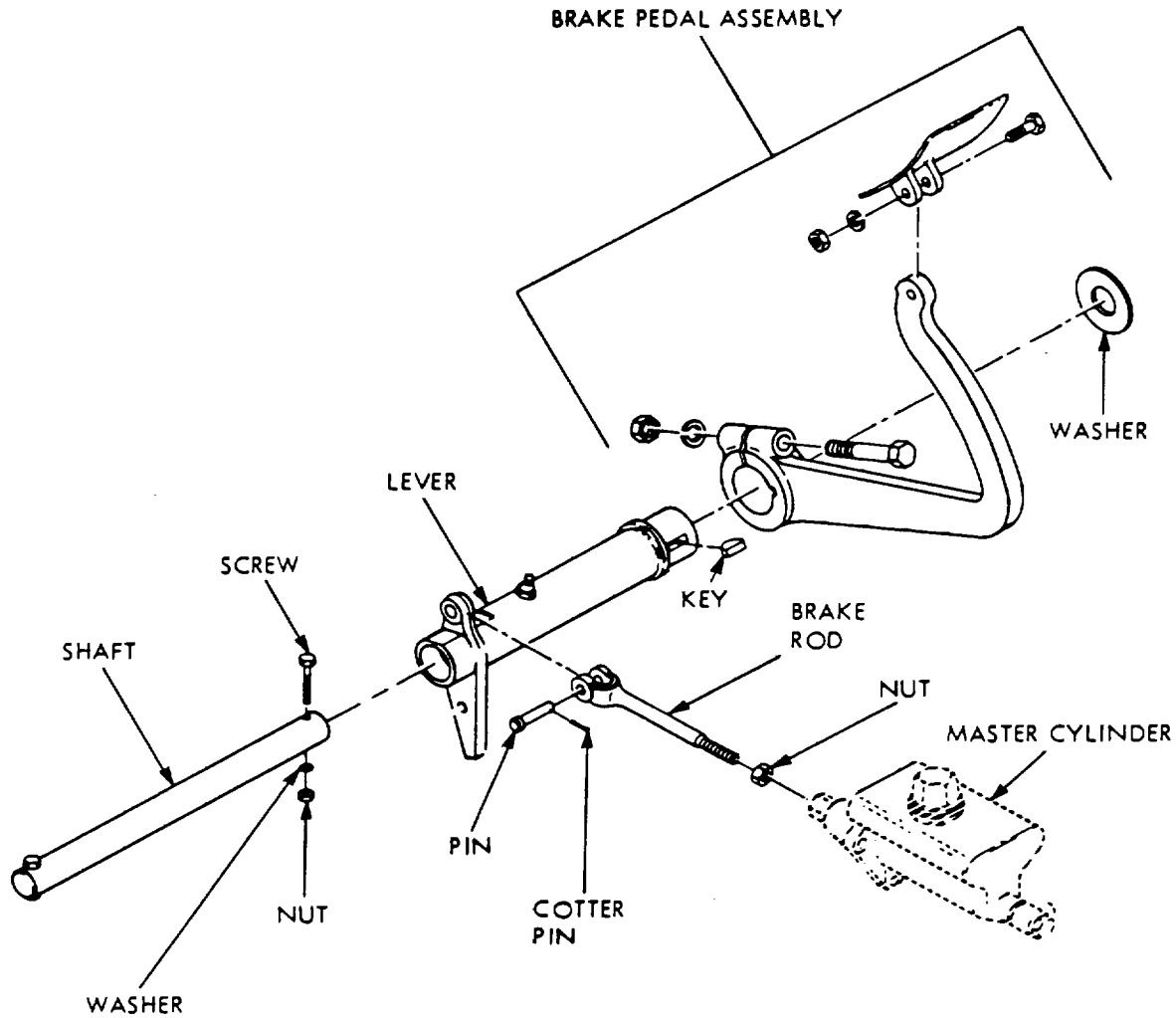

MEC 3930-256-35/17

Figure 17. Brake pedal and linkage, exploded view.

### Section VI. WHEELS

#### 23. Wheels

Refer to TM 10-3930-256-20 for removal and installation of wheels.

#### 24. Tires

Replacement is usually made by pressing off old tire simultaneously with pressing on new one. Pressure required to install tire is 5000 pounds for each inch of wheel diameter. For example, a tire used on a wheel of 18 inches diameter requires 18 x 5000 pounds, or 45 tons

press capacity for replacement. Using a press of adequate capacity, proceed as follows:

- a. Remove wheel on which tire is to be replaced (TM 10-3930-256-20).
- b. As shown in figure 18, support felloe of wheel with ring just slightly smaller in diameter than wheel felloe and at least as wide as tire to be pressed off.
- c. Place new tire over the old, and center carefully.

AGO 8176A

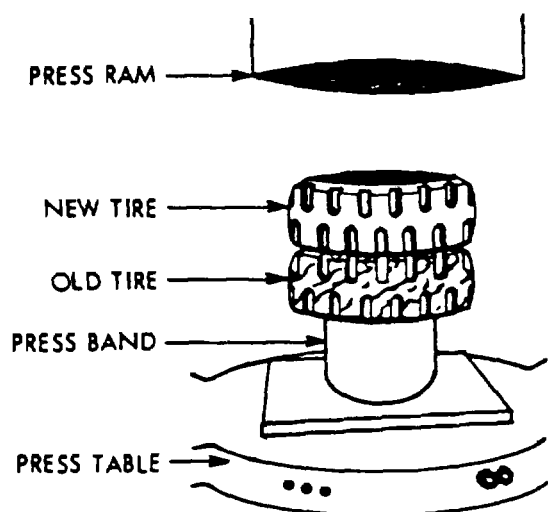

MEC 3930-256-35/18

Figure 18. Solid tire replacement.

d. Start press platen down slowly, check alignment and proceed with pressing operation.

e. Be sure that pressure is always applied through the metal base band and that there is never interference with the rubber. *Never hammer tire.* Use rings rather than blocks for applying pressure on wheels, to avoid any localized damage to tires or wheels.

*Note.* In some cases it may be difficult to remove old tire because of a peened-over condition of base band or felloe. In this event, remove old tire by burning or cutting through base band. In applying tires to wheels without old tires, take care to see that felloes are smooth and free of burrs, and that new tire is started squarely and not cocked on wheel.

## Section VII. STEERING

### 25. Steering Gear

Complete disassembly of steering gear is seldom necessary. Disassemble only to the extent necessary to perform necessary repairs. Cleanliness in the work area is of the utmost importance to a successful repair. Clean exterior of gear with SD before beginning disassembly. The following instructions present complete overhaul procedures, broken down into the most commonly required jobs short of complete overhaul.

#### a. Removal of Steering Gear.

- (1) Remove floor plate (TM 10-3930-256-20).
- (2) Disconnect horn wires, and remove steering column from truck (TM 10-3930-256-20).
- (3) Remove nut and cotter pin, and disconnect drag link from pitman arm (fig. 19).
- (4) Disconnect power steering hoses from gear (TM 10-3930-25620). Remove bolts and washers holding gear to truck, and remove steering gear.

#### b. Steering Column Disassembly.

- (1) Remove horn button, steering wheel,

and steering column (TM 10-3930-256-20).

- (2) Remove key (fig. 20) on shaft taper at steering wheel end.
- (3) Take out upper bearing spring and spring seat, then remove upper bearing. Remove retainer and dust seal, take shaft out bottom of jacket, and remove retaining ring and lower bearing.

c. *Steering Column Assembly.* Reverse b above.

#### d. Adjuster Plug Assembly.

- (1) *Removal.*
  - (a) Loosen adjuster plug locknut (3, fig. 21) with adjuster plug locknut wrench (fig. 22) or equal.
  - (b) Remove adjuster ,plug assembly with spanner wrench.
- (2) *Disassembly.*
  - (a) Remove thrust bearing retainer (10, fig. 21) with a screwdriver, being careful not to score needle bearing bore, and discard. Remove thrust bearing spacer (59), thrust bearing (60) and thrust bearing races (8 and 9).



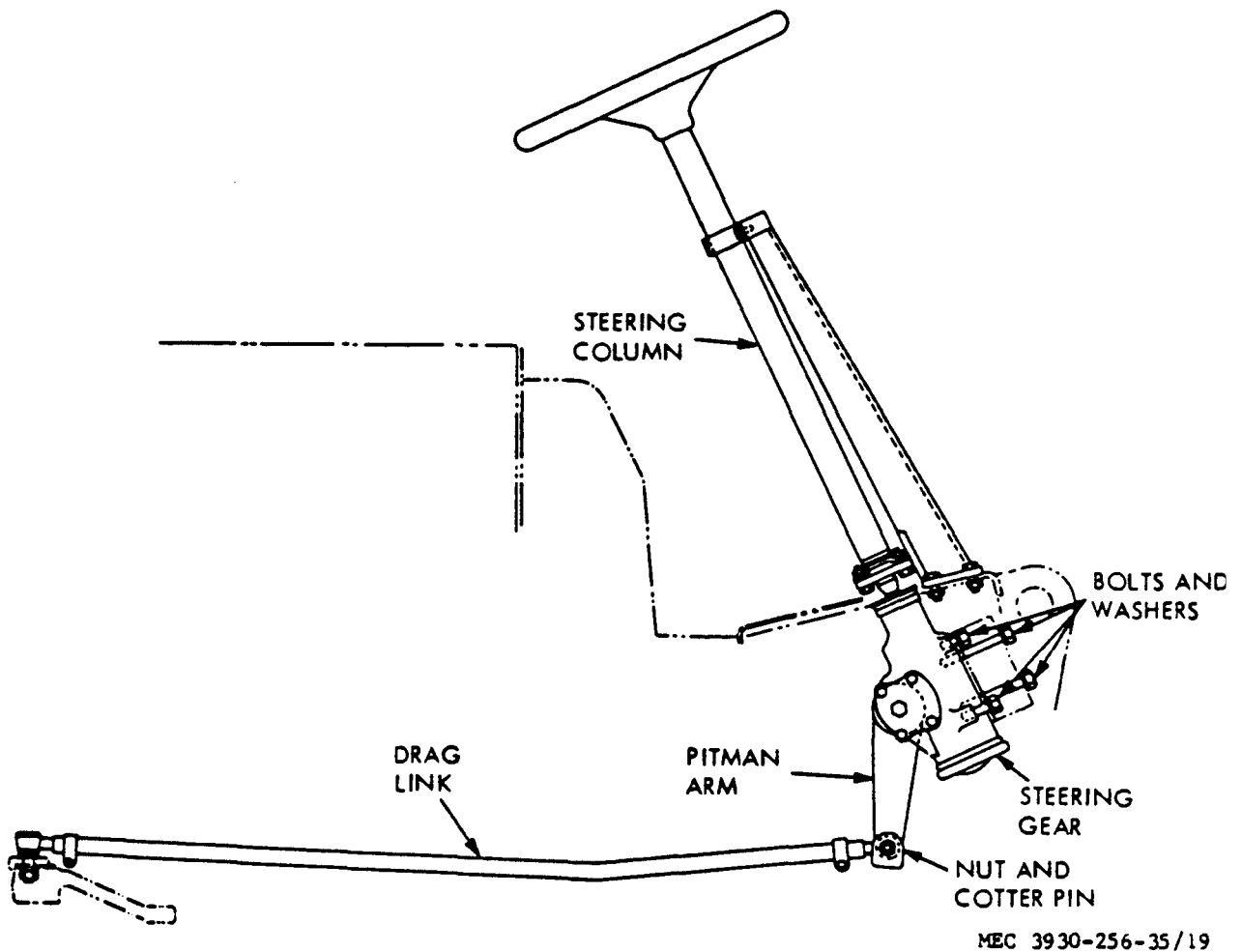

Figure 19. Steering gear arrangement.

- (b) Remove adjuster plug packing (7) and discard.
  - (c) Remove stub shaft seal retaining ring (4), with snap ring pliers, and remove stub shaft dust seal (62).
  - (d) Remove stub shaft oil seal (5) by prying out with screwdriver and discard.
  - (e) Inspect adjuster plug needle bearing (6), and if rollers are broken or pitted, remove needle bearing from adjuster plug by pressing from thrust bearing end using piloted driver. Discard bearing.
- (3) Reassembly.
- (a) Assemble needle bearing (6, fig. 21) by pressing from thrust bearing end of adjuster plug (61) against identification end of bearing. End of bearing is to be flush with bottom surface of stub shaft seal (5) bore.
  - (b) Lubricate new stub shaft seal with engine oil, OE, and install far enough to provide clearance for dust seal (62) and retaining ring (4). Lubricate new dust seal with engine oil, OE, and install with rubber surface outward. Install retaining ring (4), making certain that ring is properly seated.
  - (c) Lubricate packing (7) with GAA and install on adjuster plug. Assemble large thrust bearing race (8), thrust bearing (60), small

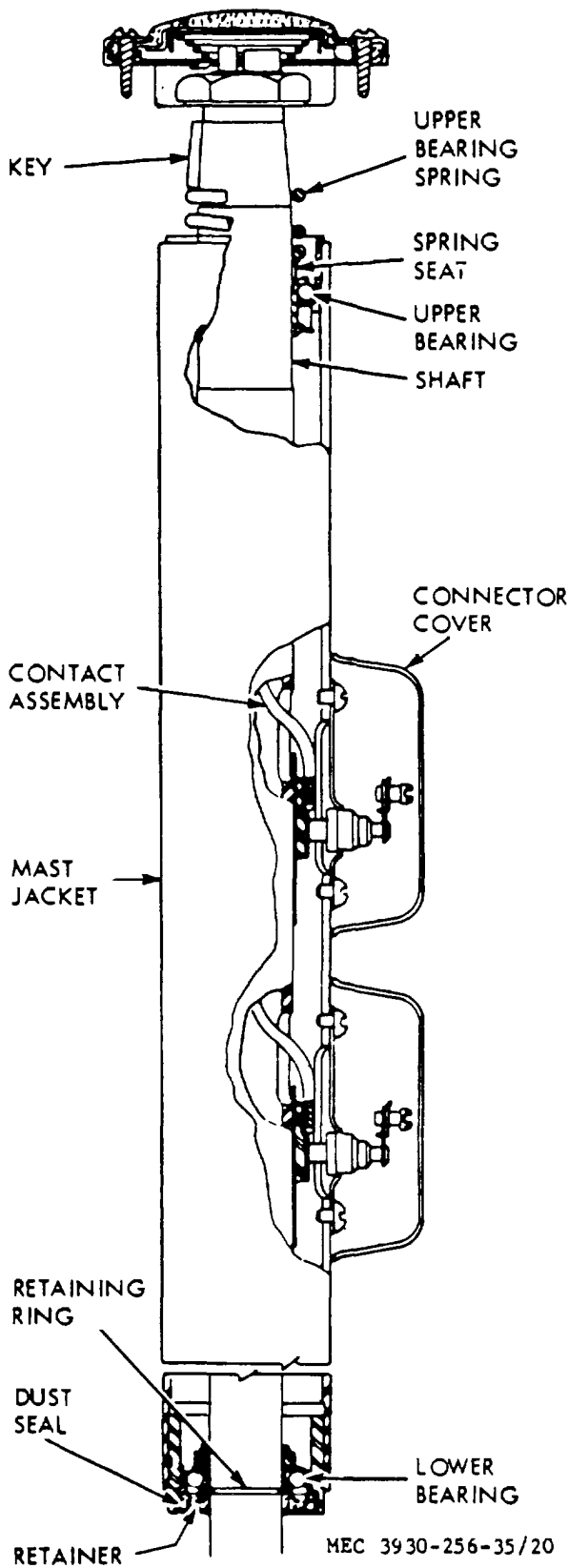

Figure 20. Steering column, cutaway view.

AGO 8176A

- |                              |                     |
|------------------------------|---------------------|
| 1 Bolt                       | 32 Washer           |
| 2 Flange                     | 33 Oil seal         |
| 3 Nut                        | 34 Oil seal         |
| 4 Retaining ring             | 35 Rack-piston-nut  |
| 5 Oil seal                   | 36 Packing          |
| 6 Needle bearing             | 37 Piston ring      |
| 7 Packing                    | 38 End plug         |
| 8 Race                       | 39 Housing end plug |
| 9 Race                       | 40 Retaining ring   |
| 10 Bearing retainer          | 41 Packing          |
| 11 Packing                   | 42 Balls            |
| 12 Spring                    | 43 Ball guide       |
| 13 Sector gearshaft          | 44 Clamp            |
| 14 Connector                 | 45 Screw            |
| 15 Connector                 | 46 Housing          |
| 16 Thrust bearing races      | 47 Washer           |
| 17 Worm                      | 48 Lash adjuster    |
| 18 Packing                   | 49 Washer           |
| 19 Torsion bar and valve cup | 50 Retainer         |
| 20 Stub shaft                | 51 Sleeve bearing   |
| 21 Valve body                | 52 Side cover       |
| 22 Valve body rings          | 53 Nut              |
| 23 Back-up packing           | 54 Screw            |
| 24 Pin                       | 55 Washer           |
| 25 Bearing                   | 56 Packing          |
| 26 Ball                      | 57 Spool            |
| 27 Bearing                   | 58 Spool spring     |
| 28 Washers                   | 59 Spacer           |
| 29 Retaining ring            | 60 Thrust bearing   |
| 30 Steering arm              | 61 Adjuster plug    |
| 31 Nut                       | 62 Dust seal        |

Figure 21. Steering gear, exploded view.

thrust bearing race (9), and thrust bearing spacer (59) on adjuster plug. Press new retainer (10) into needle bearing bore, using thrust bearing retainer installer, as shown in fig. 23.

(4) *Installation.*

(a) Place seal protector tool over end of stub shaft (20, fig. 21).

(b) Install adjuster plug assembly in gear housing. Adjust thrust bearing preload according to *k* (1) below, and tighten locknut to 50 to 110 foot pounds.

e. *Valve Assembly.* The complete valve assembly in each steering gear is a precision unit with selective fitted parts and is hydraulically balanced at assembly. Only those parts which are service items are replaceable and interchangeable. No other valve parts are individually interchangeable. If replacement of any nonserviceable valve part is necessary, the complete rotary valve assembly must be replaced.

*Note.* It is very uncommon to have to make any service repairs of the valve assembly with the exception of the valve spool dampener packing. *Do not* disassemble valve unless necessary since this may result in damage-

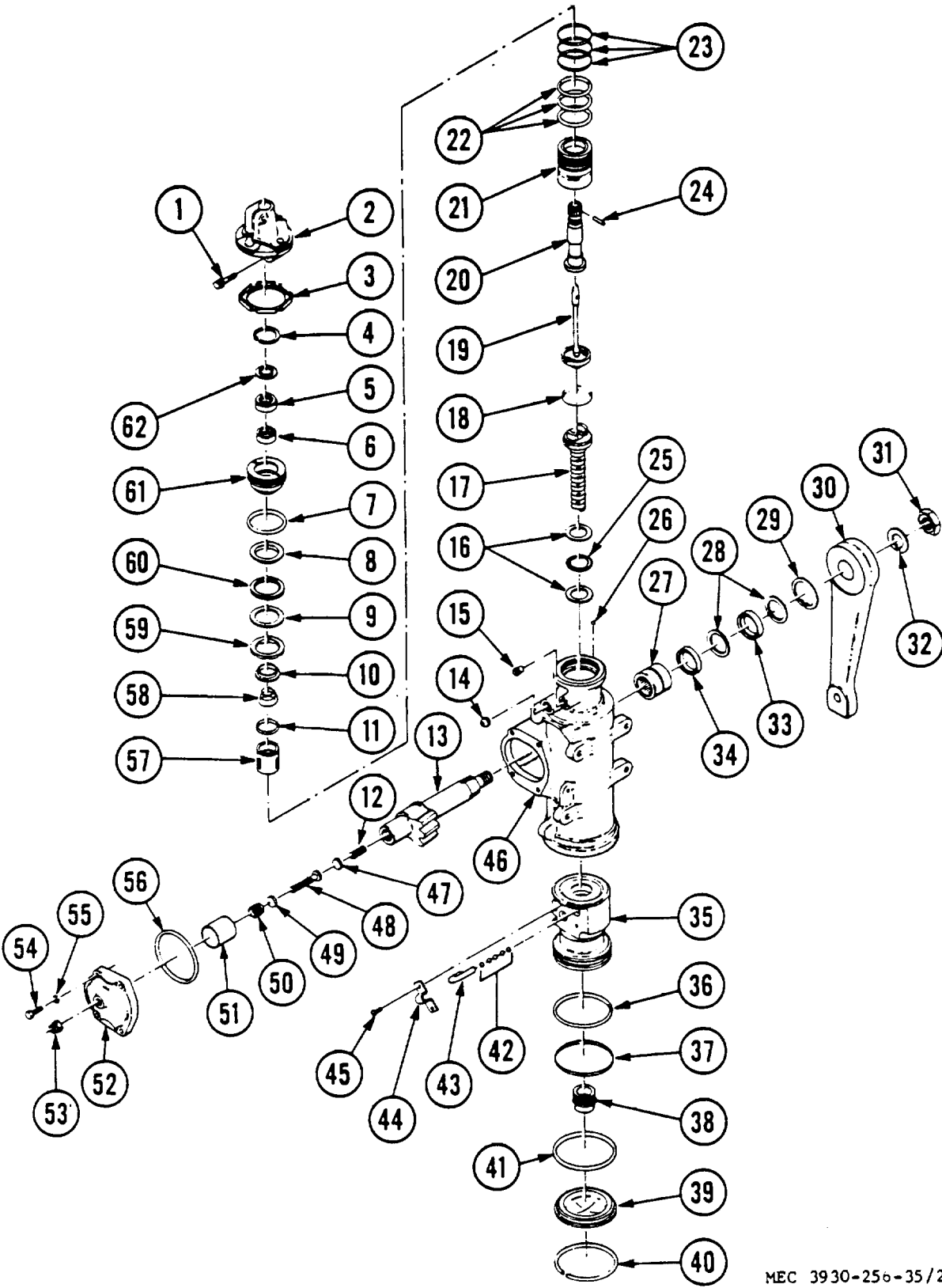

MEC 3930-256-35/21

Figure 21. Steering gear, exploded view-Continued.

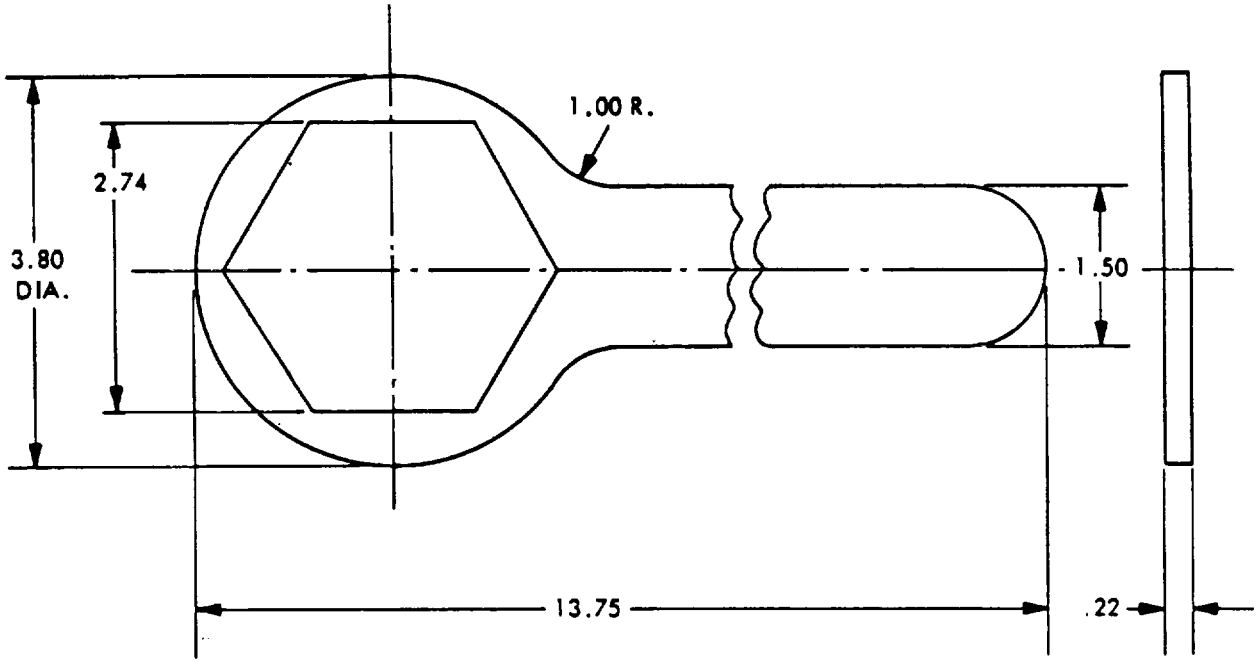

MATERIAL - S.A.E. 1008 - 1020 STEEL  
HEAT TREATMENT -  
CARBURIZE - .010/ .015 DEEP

MEC 3930-256-35/22

Figure 22. Adjuster plug locknut wrench.

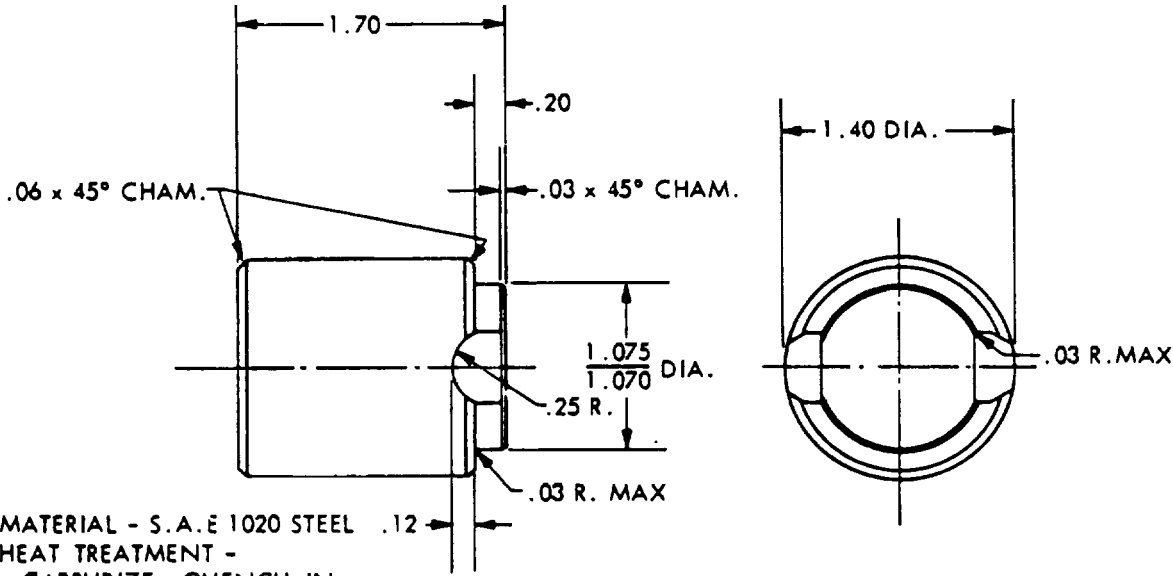

MATERIAL - S.A.E 1020 STEEL  
HEAT TREATMENT -  
CARBURIZE, QUENCH IN  
WATER - FILE HARD

MEC 3930-256-35/23

Figure 23. Thrust bearing retainer installer.

ing the assembly. If valve spool dampener packing requires replacement, remove valve spool only, replace packing, and reinstall spool immediately. *Do not* disassemble further.

(1) *Removal.*

- (a) Remove adjuster plug assembly as outlined under *d* above.
- (b) Remove valve assembly from gear by grasping stub shaft (20, fig. 21) and pulling out valve assembly and stub shaft.

(2) *Disassembly.*

- (a) Remove packing (18, fig. 21) and discard.
- (b) Remove spool spring (58) by prying small coil, using small screwdriver.

*Caution:* Do not pry against valve body (21), as this may result in a sticky valve. Work spring onto bearing diameter of stub shaft (20). Slide spring off stub shaft.

- (c) Remove valve spool (57) with extreme care.

*Caution:* The diametral clearance between valve body and spool may be as low as 0.0004 inches. The slightest cocking of spool may jam it in valve body. To remove valve spool (57), hold valve assembly in both hands with stub shaft pointing downward. Push lightly on valve spool with a small rod by inserting rod through openings in valve cap (19) until spool is far enough out of valve that it may be grasped by the hand. Withdraw spool with a steady oscillating pull to prevent jamming. If slight sticking occurs, make a gentle attempt to reverse withdrawal procedure. If this does not free spool, it has become cocked in valve body bore. Do not attempt to force spool in or out if it becomes cocked. In this case, continue to disassemble valve assembly as follows and return to the spool as described in (e) below.

- (d) Remove stub shaft (20), torsion bar and valve cap assembly (19) by holding valve assembly in both

hands as before, only with thumbs on valve body. Rap torsion bar lightly against work bench. This will dislodge the cap from the valve body to cap pin. The stub shaft, torsion bar and valve cap assembly can now be removed from valve body. If valve spool has become cocked as described in (c) above, it can now be freed. By visual inspection on a flat surface it can be determined in which direction spool is cocked. A few very light taps with a light soft plastic or rawhide mallet should align spool in the bore and free it.

*Caution:* Do not tap with anything metallic. If spool can be rotated, it can be removed.

- (e) Remove dampener seal packing (11) from spool and discard.
- (d) Providing rings show evidence of excessive wear, carefully cut valve rings (22) and ring back-up packing (23), remove and discard. The valve rings are made of filled teflon and it is very unusual that replacement is required.

(3) *Inspection.*

- (a) If valve assembly leaks externally around torsion bar, replace entire assembly.
- (b) Check pin in valve body (21, fig. 21) which engages cap. If it is badly damaged, entire valve assembly must be replaced.
- (c) Check worm pin groove (the smaller of the two) in valve body. If it is damaged, entire valve assembly must be replaced.
- (d) Check spool drive pin in stub shaft. If it is worn badly, cracked or broken, entire valve assembly must be replaced.
- (e) Examine spool (57) surface for nicks and burrs. If any are found, they must be removed with a very fine hone. A slight polishing is normal on valving surfaces.
- (f) Examine valve body bore for nicks

or burrs. If any are found, they can be removed with light crocus cloth until spool turns freely in body. Be careful not to remove any stock from surface of body. As on the spool, a slight polishing is normal on valving surfaces.

(4) *Reassembly.*

(a) Lubricate valve ring back-up packings (23) in OE. Assemble in three ring grooves on valve body. Assemble valve rings (22) in ring grooves over back-up packings by carefully slipping rings over valve body. The rings may appear loose or twisted in the grooves, but the heat of the oil after assembly will cause them to tighten.

(b) Install new valve spool dampener packing in valve spool groove.

(c) Assemble stub shaft in valve body. Align groove in valve cap with pin in valve body. Tap lightly on cap with plastic or rawhide mallet until cap is against shoulder in valve body with valve body pin in cap groove.

*Caution:* Make sure groove and pin are in line before tapping on cap. Hold these parts together during rest of assembly.

(d) Lubricate valve spool with OE. Slide spool over stub shaft with notch toward valve body. Align notch with spool drive pin in stub shaft and carefully engage spool in valve body bore.

*Caution:* Because clearance between spool and valve body is very small, extreme care must be taken when assembling these parts. Push spool evenly and slowly with a slight oscillating motion until spool reaches drive pin. Rotate spool slowly with pressure until notch engages pin. Before pushing spool completely in, make sure dampener packing is evenly distributed in spool groove. Slowly push spool completely in, with extreme care taken not to cut or pinch packing.

(e) Place seal protecting tool over stub shaft. Slide spool spring over seal protector and work spool spring down until it is seated in stub shaft groove. Take care not to mar sealing surface of stub shaft.

(f) Lubricate new cap-to-worm packing in OE and install in valve assembly.

(g) If during assembly of valve, stub shaft and cap assembly is allowed to slip out of engagement with valve body pin, spool may enter valve body too far. The dampener packing will expand into valve body oil grooves, preventing withdrawal of spool. Attempt to withdraw spool with slight pull and much rotary motion. If this does not free spool after several tries, make sure spool is free to rotate; place valve body on flat surface with notched end up, and tap spool with wooden or plastic rod until packing is cut and spool can be removed. Replace packing and proceed with assembly as before.

(5) *Installation.*

(a) Align valve body drive pin in worm (17, fig. 21) with narrow pin slot on valve body. Insert valve assembly into gear housing.

*Caution:* Do not push against stub shaft as this may cause stub shaft and cap to pull out of valve body, allowing spool seal to slip into valve body oil grooves as described in the preceding section. Valve assembly should be pushed in by pressing against valve body with finger tips. Be sure valve is properly seated before assembling adjuster plug assembly. Return hole in gear housing should be fully visible at this time.

(b) Install adjuster plug assembly as outlined in *d* above.

f. *Sector Gearshaft Assembly and Side Cover.*

(1) *Removal of pitman shaft seals with gear in truck.*

- (a) Remove steering arm nut (81, fig. 21), lockwasher (32), and steering arm (30). Place an oil-catch basin beneath steering gear.
  - (b) Remove sector gearshaft seal retaining ring (29), and outer seal back-up washer (28).
  - (c) With steering pump running, and hoses attached, momentarily hold steering wheel in extreme left turn position. This actuates valve, allowing pressure to build up on upper side of piston, and in gearshaft chamber, thereby forcing out seals (33 and 34) and inner seal back-up washer (28). To prevent undue oil loss and pump wear, do not hold wheel for more than a second or two at a time.
  - (d) Turn off steering pump. Remove seals and inner back-up washer from shaft and discard seals.
- (2) *Removal of sector gearshaft and side cover.*
- (a) Disconnect hoses and remove steering gear from truck.
  - (b) Drain out as much of remaining oil as possible.
  - (c) Rotate stub shaft (20, fig. 21) until sector gearshaft (13) is in center position and remove side cover retaining screws (54). Tap end of gearshaft with soft mallet and slide gearshaft out of housing.
  - (d) Remove side cover packing (56) from side cover and discard.
- (3) *Disassembly.*
- (a) Hold lash adjuster (48, fig. 21) with a hex key wrench and remove lash adjuster nut (53) and discard. Screw lash adjuster out of side cover (52).
  - (b) Remove sector gearshaft seal retaining ring (29), and outer backup washer (28). Tap a screwdriver between outer seal and inner backup washer and pry out seal. Tap the screwdriver between inner seal and shoulder in gear housing and pry out seal. Be careful not to damage seal bore. Discard seals.
  - (c) Remove needle bearing (27) from gear housing bore by pressing on the stamped identification end of bearing. Discard bearing.
- (4) *Inspection.*
- (a) Inspect sleeve bearing (51, fig. 21) in side cover (52) for excessive wear or scoring. If badly worn or scored, replace side cover and bearing as an assembly.
  - (b) Check sector gearshaft teeth and bearing and seal surfaces. If badly worn, pitted, or scored, replace gearshaft assembly.
  - (c) Check needle bearing (27) in housing.
- (5) *Assembly.*
- (a) Assemble new needle bearing (27, fig. 21) into gear housing (46) bore from seal bore end, pressing against stamped identification end. Press in until bearing clears shoulder in gear housing 0.030 inch maximum.
  - (b) Lubricate new gearshaft seals in OE. Install *single* lip seal first, then a back-up washer. Drive seal and washer in far enough to provide clearance for other seal, back-up washer, and retaining ring (29). Seal must not bottom on end of counterbore. Install *double* lip seal and second back-up washer. Drive seal and back-up washer in only far enough to provide clearance for retaining ring. Install sector gearshaft retaining ring. Be certain this ring is seated properly.
  - (c) Assemble side cover (52) and bearing (51) assembly on sector gearshaft assembly. Screw lash adjuster (48) through side cover until side cover bottoms on gearshaft, and back off 1/2 turn.
- (5) *Installation.*
- (a) Lubricate new side cover packing (56, fig. 21) and install in groove in face of side cover.
  - (b) Turn stub shaft (20) as necessary until middle rack groove is aligned with center of gearshaft needle bearing (27).

- (c) Install gearshaft so that center tooth in sector gear meshes with center groove of rack-piston (35). Make sure that side cover packing is in place before pushing side cover down on gear housing.
- (d) Install side cover screws (54) and tighten to 30 to 35 foot pounds.
- (e) Install lash adjuster nut (53) on lash adjuster without tightening. Adjust gearshaft per specification. Hold lash adjuster from rotating with a hex key wrench and tighten lash adjuster nut to 20 to 30 foot pounds.

*g. Housing End Plug.*

(1) *Removal.*

- (a) Rotate end plug retainer ring (40, fig. 21) so that one end of ring is over hole in housing. Spring one end of ring with punch to allow screwdriver to be inserted to lift ring out.
- (b) Rotate stub shaft (20) to left turn corner position and force end plug (39) out of housing.

*Caution:* Do not rotate further than necessary or the balls from the rack and worm assembly will fall off end of worm.

- (c) Remove and discard housing end plug packing (41).

(2) *Installation.*

- (a) Lubricate new housing end plug packing (41) with OE and install in gear housing (46).
- (b) Insert housing end plug (39) into gear housing and seat against packing.
- (c) Install end plug retainer ring (40) with fingers. Install one end of ring and work ring into groove until seated. Slight tapping may be required to securely bottom retainer ring in gear housing.

*h. Rack-Piston End Plug.*

(1) *Removal.*

- (a) Remove housing end plug as outlined under *g* (1) above.

- (b) Remove rack-piston end plug (38, fig. 21).

(2) *Installation.*

- (a) Turn plug into rack-position and tighten to 50 or 100 foot pounds.
- (b) Install housing end plug as outlined under *g* (2) above.

*i. Rack-Piston and Worm Assembly and Gear Housing Assembly.*

(1) *Removal.*

- (a) Remove housing end plug as outlined under *g* (1) above.
- (b) Remove rack-piston end plug as outlined under *h* (1) above.
- (c) Remove sector gearshaft assembly as outlined under *f* (2) above.
- (d) Insert rack-piston arbor (see figure 24 for tool details) in end of worm (17, fig. 21). Rotate stub shaft to left turn, which will force rack-piston nut (35) onto arbor, and remove rack-piston nut from gear housing, taking care to keep arbor in place in rack-piston nut or the balls will fall out. If rack-piston nut is being removed to replace piston ring (37, fig. 21) and back-up packing (36), reassemble without further disassembly.
- (e) Remove valve assembly as outlined under *e* above.
- (f) Remove worm, lower thrust bearing and races.

(2) *Disassembly.*

- (a) Refer to (3) below.
- (b) Cut piston ring (37, fig. 21) and packing (36) back-up seal, remove from rack-piston nut (35) and discard.
- (c) Remove screws and lock washers (45) from rack-piston nut with screwdriver.
- (d) Remove ball return guide clamp (44).
- (e) Place assembly on a clean cloth and remove ball return guides (43) and arbor. Make sure all of the balls (42) are caught on the cloth.

(3) *Inspection*

- (a) Inspect housing assembly. If bore



is badly scored or worn, replace housing. If connectors (14 and 15, fig. 21) are badly brinelled or scored, replace them. To remove connectors, tap threads using a 5/6-18 tap. Thread a bolt with a nut and flat washer attached into tapped hole. To pull connector, hold bolt from rotating while turning nut off bolt. This will pull the connector from gear housing. Discard connectors.

- (b) Inspect ball plug (26) in housing. If it is leaking or raised above housing surface, it may be driven in flush to 1/16 inch below the surface. The ball can be tightened by staking the housing. If leakage cannot be stopped, housing must be replaced.
- (c) Inspect all seal surfaces and retaining ring grooves for defects. If any defects are found, housing must be replaced.
- (d) At initial assembly, rack-piston nut, worm and balls are selected to obtain a preload of 1 to 4 inch pounds measured on center through an angle of 90°. This preload may drop during service, but this will not have any noticeable effect on steering, and ordinarily will not need any refitting to gain preload. The preload may be checked, if so desired, by using the method described under *j* below. Upon complaint of loose or hard steering, thrust bearing adjustment and overcenter adjustment will correct the problem if it lies in steering gear adjustments. If not, check rack-piston nut and worm assembly for excessive lash or excessive load overcenter and also for roughness at any point along the worm. If any of these conditions is found, disassemble the assembly and inspect worm and rack-piston nut grooves and all the balls for excessive wear or scoring. If either worm or rack-piston nut need replacing, both must be replaced as a matched assembly. The lash or

heavy load may be corrected by replacing standard balls with a larger or smaller size-black balls need not be replaced unless they are defective. In event black balls cannot be distinguished from standard balls, replace with new balls using method described under (4) (f) below.

- (e) Inspect ball return guides (43), making sure that the ends where balls enter and leave guides are not damaged.
  - (f) Inspect lower thrust bearing and races.
  - (g) Inspect rack-piston nut teeth for wear and chipping. Inspect rack-piston nut surface for scoring or burrs.
- (4) *Reassembly.*
- (a) Thoroughly clean parts and lubricate internal parts with OE.
  - (b) Drive new connectors (14 and 15, fig. 21) in place with piloted driver.
  - (c) Lubricate new back-up packing (36) with OE. Assemble in piston ring groove on rack-piston nut (35). Install new piston ring (37) in ring groove over the packing by carefully slipping ring over rack-piston nut. The ring may be slightly loose after assembly. This is normal and it will tighten when subjected to the hot oil in the system.
  - (d) Insert worm (17) into rack-piston nut, to bearing shoulder.
  - (e) Align ball return guide holes with worm groove. Load 16 balls (42) into guide hole nearest piston ring, while slowly rotating worm (17) counterclockwise to feed balls through circuit. Alternate black balls with standard balls.
  - (f) Fill one ball return guide with remaining 6 balls. Place other guide over balls and plug ends with grease, GAA, to prevent balls from falling out when installing guide into rack-piston nut.
  - (g) Insert guides into guide holes of

- the rack-piston nut. Guides should fit loosely.
- (h) Place return guide clamp over guides and install 2 screw and lock-washer assemblies and tighten to 8 to 12 foot pounds.
  - (i) Insert rack-piston arbor tool into worm and turn rack-piston onto arbor. Do not allow arbor to separate from worm until rack-piston nut is fully on arbor.
- (5) *Installation.*
- (a) Assemble thrust bearing (25, fig. 21) and races (16) on worm (17). Assemble valve assembly to worm by aligning small slot in valve body (21) with pin on worm. Be sure to install packing (18) between body and worm head.
  - (b) Install valve assembly and worm in housing (46) as integral unit and continue valve assembly as outlined in e above. Adjust thrust bearings (k (1) below).
  - (c) Install piston ring compressor (see figure 25 for tool details) in gear housing (46, fig. 21). Hold it *tight* against shoulder in housing. Insert rack-piston nut (35) into the housing until arbor engages worm. Turn stub shaft (20) clockwise, drawing

rack-piston nut into housing. When piston ring is in housing bore, withdraw arbor from rack-piston nut.

- (d) Install rack-piston plug as outlined under *h* above.
- (e) Install housing end plug as outlined under *g* above.
- (f) Install sector gearshaft and side cover as outlined under *f* above.

*j. Steering Gear Adjustments* (Gear installed in truck). All adjustments listed below or else-where in this manual are initial factory assembly adjustments. During breaking-in period, it is probable that some of these adjustments will change. These changes in adjustments do not necessarily affect satisfactory operation of the steering gear assembly and ordinarily do not require readjustment unless there is excessive lash or other malfunctioning. Under normal conditions, thrust bearing adjustment and worm to rack preload need never be changed. Consequently, if lash develops in steering gear, the sector gearshift should be adjusted in the truck as follows:

- (1) Disconnect steering arm from sector gearshift and remove horn button (TM 10-3930-25-20).
- (2) Turn gear 1/2 turn off center (either direction). Using a 24 inch pound torque wrench on steering wheel nut,

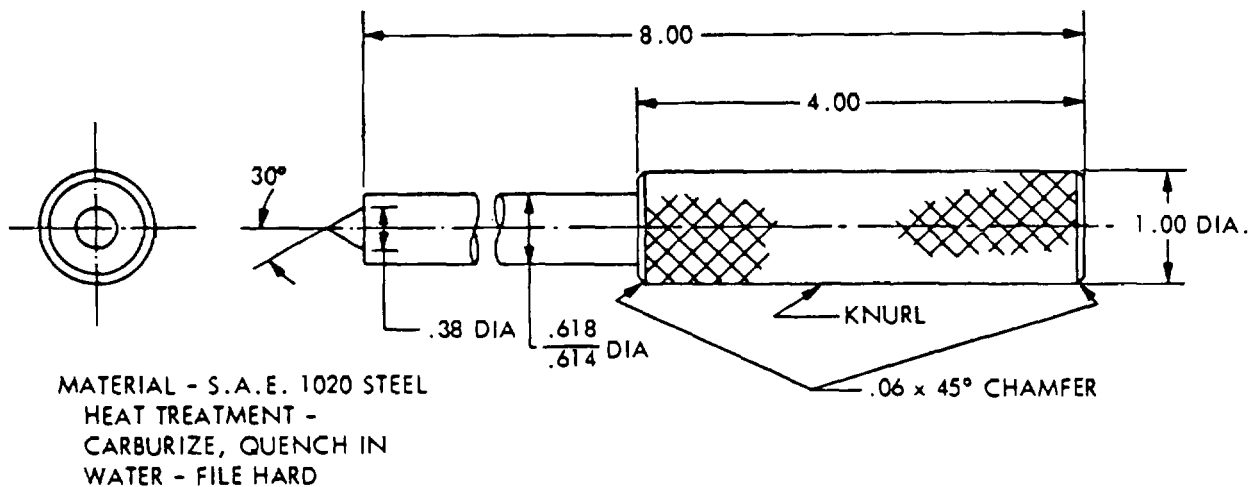

MEC 3930-256-35/24

Figure 24. Rack-piston arbor.

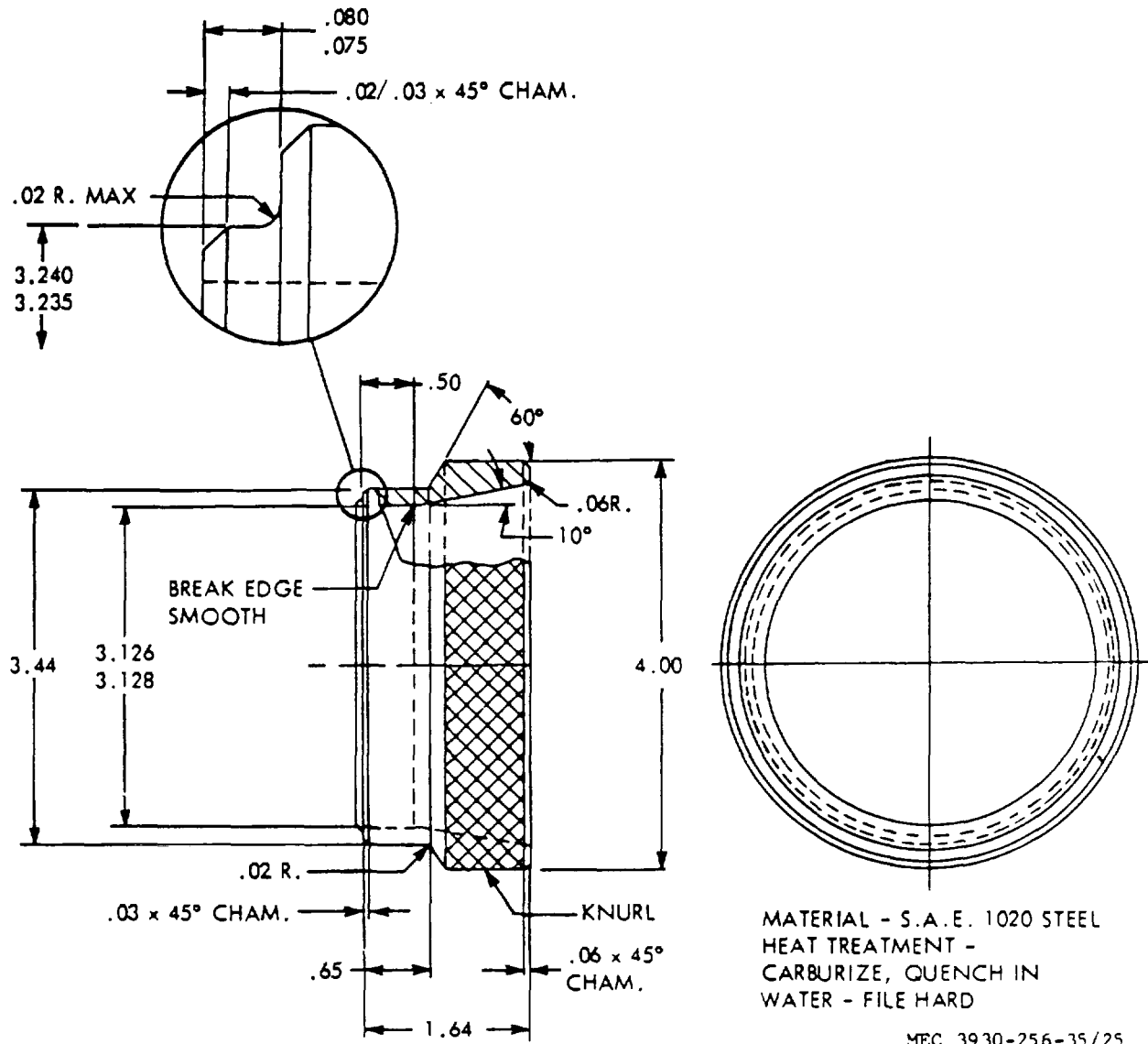

Figure 25. Piston ring compressor.

determine torque required to rotate shaft slowly through a 20° arc.

- (3) Turn gear back to center and repeating method of reading torque as in (2) above, loosen adjuster nut, turn screw in until reading is equal to 6 inch pounds in excess of (2) above, and retighten locknut while holding screw in place.
- (4) Recheck readings and replace steering arm and horn button.

k. Gear Adjustments after Disassembly.

- (1) Thrust bearing adjustment. This adjustment is to be made after worm,

thrust bearings, valve assembly, adjuster plug assembly, and locknut are assembled in housing assembly. Proceed as follows:

- (a) Before adjusting preload, tighten adjuster plug up snug, back off slightly (1/8 turn) and measure valve assembly drag.
- (b) Turn adjuster plug in so that preload is 1 to 3 inch pounds in excess of valve assembly drag. Tighten locknut. Total thrust bearing adjustment and seal drag is not to exceed 8 inch pounds.

- (2) *Worm and rack-piston nut adjustment.*  
Select fit of worm, rack-piston nut and balls to provide some preload not to exceed 41/2 inch pounds measured on center of worm.
- (3) *Overcenter or sector gearshift adjustment.*  
This adjustment is to be made after gear is completely assembled. With gear on center and lash adjuster backed off, measure total drag. With gear on center, adjust lash adjuster so that preload is 4 to 8 inch pounds in excess of total preload and drag. Readings are to be made through an arc not exceeding 20° with gear on center. Tighten lash adjuster locknut.

- (b) Before adjusting preload, tighten adjuster plug up snug, back off slightly (1/8 turn) and measure valve assembly drag.
  - (c) Turn adjuster plug in so that pre-load is 1 to 3 inch pounds in excess of valve assembly drag. Tighten locknut.
  - (d) Total thrust bearing adjustment and seal drag is not to exceed 8 inch pounds.
- (2) *Overcenter or lash adjuster adjustments.*  
With gear on center and lash adjuster backed off, measure total drag. With gear on center, adjust lash adjuster so that preload is 4 to 8 inch pounds in excess of total preload and drag. Readings are to be made through an arc not exceeding 20° with gear on center. Tighten locknut.

*l. Adjustment If Not Disassembled.*

- (1) *Thrust bearing adjustment.*
  - (a) Turn gear into either right or left corner and back off 1/4 turn.

*m. Troubleshooting.*

- (1) *Hard steering while driving.*

*Probable cause*

*Remedy*

Frozen sector gearshaft bearings-----	Replace bearings.
Lower coupling flange rubbing against adjuster -----	Loosen bolt and assemble properly.
Steering wheel rubbing against mast jacket -----	Adjust jacket endwise.
Steering adjustment tight -----	Check adjustment by dropping steering arm from gear or disconnecting linkage from drag link. Readjust if necessary.

- (2) *Poor return of steering.*

*Probable cause*

*Remedy*

Frozen sector gearshaft bearings-----	Replace bearings.
Lower coupling flange rubbing against adjuster -----	Loosen bolt and assemble properly.
Steering wheel rubbing against mast jacket-----	Adjust jacket endwise.
Incorrect wheel alignment -----	Adjust to specification.
Tight steering linkage-----	Lubricate.
Steering adjustment tight -----	Check adjustment by disconnecting drag link from steering arm. Readjust if necessary.
Sticky valve spool-----	Remove and clean valve or replace valve.

- (3) *Momentary increase in effort when turning wheel fast to the left or right.*

*Probable cause*

*Remedy*

Low oil level in pump-----	Check oil level in pump reservoir.
High internal leakage -----	Replace rack-piston ring and back-up packing, rack-piston end plug, valve body to worm seal and/or replace valve.

- (4) *External oil leaks (wipe gear thoroughly and make sure source of leakage is determined).*

*Probable cause*

*Remedy*

Loose hose connections -----	Tighten.
Damaged hose -----	Replace.
Side cover packing -----	Replace seal.
Sector gearshaft seals-----	Replace seals.
Housing end plug seal-----	Replace seal.
Adjuster plug seals -----	Replace seal.
Torsion bar seal-----	Replace valve.

(5) *Gear noise (rattle or chuckle).*

*Note:* A slight rattle may occur on turns because of the increased lash off the "high point". This is normal.

*Probable cause*

*Remedy*

Loose overcenter adjustment ----- Adjust to specification.

Gear loose on frame ----- Check gear-to-frame mounting bolts. Tighten bolts to specifications.

(6) *Gear noise ("hissing" sound).*

*Probable cause*

*Remedy*

There is some noise in all power steering systems.

One of the most common is a "hissing" sound most evident at standstill parking. There is no relationship between this noise and performance of the steering. "Hiss" may be expected when steering wheel is at end of travel, or when slowly turning at standstill.

Do not replace valve unless "hiss" is extremely objectionable.

Slight hiss is satisfactory and in no way affects steering. A replacement valve may also exhibit slight noise and is not always a cure for the objection. Be sure steering shaft and gear are aligned so the flexible coupling rotates in a flat plane and is not distorted as shaft rotates. Any metal-to-metal contact through the flexible coupling will transmit the valve hiss.

(7) *Excessive wheel kickback or loose steering.*

*Probable cause*

*Remedy*

Lash in steering linkage ----- Adjust parts affected.

Excessive lash between sector gearshaft and rack-piston. ----- Adjust to specifications.

Loose thrust bearing adjustment ----- Remove gear and adjust to specification.

Ball nut and worm preload ----- Remove rack-piston and worm, and change balls to obtain specified preload.

(8) *Hard steering when parking.*

*Probable cause*

*Remedy*

Low oil level in reservoir ----- Fill to proper level. If excessively low, check all lines and joints for evidence of external leakage.

Lack of lubrication in linkage ----- Add lubricant where needed.

Insufficient oil pressure ----- If all of the above checks do not reveal the cause of hard steering, make the following tests of oil pressure:

A. Disconnect the pressure line at oil pump. Attach gauge to pump. Connect the hose to end of gauge where the valve is located.

B. With engine at warm idle and gauge valve open, note the oil pressure on the gauge while turning steering wheel from one extreme position to the other. Especially note the maximum pressure which can be built up with the wheel held in either right or left extreme position.

*Caution:* Do not hold wheel in extreme position for an extended period of time because it will drastically increase the oil temperature and will cause undue wear on the oil pump.

C. With oil temperature between 150°F. and 170°F. as measured with a thermometer in the reservoir, the maximum oil pressure should not be less than 925 psi for satisfactory power steering operation.

D. If the maximum oil pressure is less than 925 psi, it indicates trouble in the pump, oil hoses, steering gear, or a combination of these parts. To eliminate the hoses and gear, close the gauge valve and quickly test pressure of the pump only with the engine at warm idle, then open the valve to avoid increasing oil temperature.

E. Comparing the maximum pressures obtained in these two tests will indicate source of trouble as follows:

*Probable cause*

*Remedy*

1. First test (step B) pressure low, and second test (step D) pressure normal indicates faulty external oil lines or steering gear.
  2. First test (step B) and second test (step D) pressure equally low-indicates faulty oil pump.
- If above test shows trouble to be in pump, see paragraph 28. If trouble is shown to be in steering gear or hoses, examine for external oil leaks.

Low oil pressure due to restriction in hoses-

- |  |   |
|--|---|
| (A) Check for kinks in hoses -----     | Remove kink.  |
| (B) Foreign object stuck in hose ----- | Remove hoses and remove restricting object or replace hose. |

Low oil pressure due to steering gear-

- |   |   |
|---|---|
| (A) Pressure loss in cylinder due to worn piston ring or scored housing bore. | Remove gear from truck for disassembly and inspection of piston ring, back-up seal, and housing bore. |
| (B) Leakage at valve rings, valve body to worm seal, rack-piston end plug.    | Remove gear from truck for disassembly and repair.  |
| (C) Leaky valve body-----   | Replace valve.  |
- (9) *Valve squawk when turning or when recovering from a turn.*

*Probable cause*

*Remedy*

Cut or worn dampener ring on valve spool -----	Replace dampener ring, being careful not to cut the new ring at installation.
--	---

Loose or worn valve-----	Replace valve.
--------------------------	----------------

(10) *No effort required to turn.*

*Probable cause*

*Remedy*

Broken torsion bar -----	Replace valve.
--------------------------	----------------

**26. Tie Rods**

a. *Removal.* Remove cotter pin and nut from each tie rod end (fig. 26), and remove tie rod ends from steering knuckles and bell crank.

b. *Installation.* Reverse a above.

c. *Adjustment.* Refer to TM 10-3930-256-20.

**27. Bell Crank**

a. *Removal.*

- (1) Remove steering axle (para. 16a).
- (2) Remove retaining ring and upper washer (fig. 26) and lift bell crank from axle.

b. *Disassembly.* Refer to para 16b(3).

c. *Assembly.* Reverse para. 16b(3).

d. *Installation.* Reverse a above.

**28. Steering Pump**

a. *Removal and Installation.* Refer to TM 10-3930-256-20.

b. *Disassembly. Note.* Discard all used packings and shaft seal (fig. 27).

AGO 8176A

- (1) Remove discharge fitting (fig. 27) and draw reservoir from pump.
- (2) Clamp pump mounting flange in a vise with protective jaws. Remove cover mounting screws. Take cover from pump body. Remove pressure plate and spring.
- (3) Remove adapter plate and related packings shown.
- (4) Remove pump ring, locating pins, rotor and vanes, and pump ring packing.
- (5) Mount cover in vise. Drive out retaining pin with pin punch.

*Caution:* Be careful that relief valve parts do not fall from bore.

- (6) Take plug and packing, valve and spring from bore. These parts are accessible through large hole inside cover.
- (7) Remove gearshaft and seal from pump body.

*Note.* Shaft bushing in body is not to be serviced separately. If bushing is worn, replace pump body.

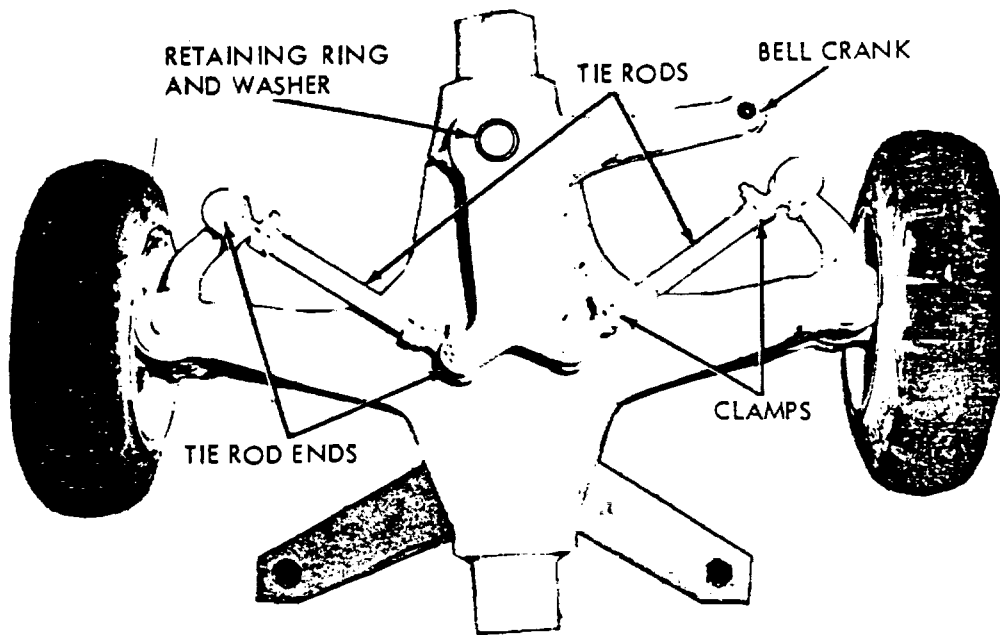

MEC 3930-256-35/26

Figure 26. Tie rods and bell crank.

c. *Cleaning.*

- (1) Thoroughly clean all parts in SD. Dry with compressed air.
- (2) Thoroughly clean all internal passages of pump cover, housing, and body.

d. *Inspection, Repair, Replacement.*

- (1) *Ring, rotor, vanes, pressure plate, body.* Inspect surfaces of all parts which are subject to wear. Light scoring may be removed from faces of body or wear plate with crocus cloth (by placing cloth on flat surface), medium India stone or by lapping. Check edges of vanes for wear. Vanes must not have excessive play in slots or burrs on edges. Replace if necessary. Check each rotor slot for sticky vanes or wear. Vanes should drop in rotor slots by their own weight when both slot and vane are dry.
- (2) *Relief valve.* Insert valve in its bore in pump cover. There should be no binding. Check valves and bore for excessive wear and scoring. Replace if necessary.

- (3) *Gearshaft and seal.* Replace gearshaft seal at each overhaul to prevent oil leakage. Check gearshaft oil seal diameter for wear and scoring. Do not install new seal on gearshaft which is worn or damaged at oil seal diameter. Replace gearshaft if worn. Stone and polish sharp edges of gear-shaft to prevent damage to seal.
- (4) *Body and cover.* Stone all mating surfaces with a medium India stone to remove all burrs and sharp edges. Rewash all parts after stoning.

e. *Assembly.* Liberally coat all parts with oil OE, and assemble as follows:

- (1) Carefully install gearshaft. Avoid damaging bushing and new seal.
- (2) Install locating pins in pump body. Install ring over pins in correct direction of rotation.
- (3) Install rotor with chamfered edge of splined hole "in" or toward pump body. The chamfer facilitates assembly.
- (4) Install vanes with their radius edges toward the inner ring contour.

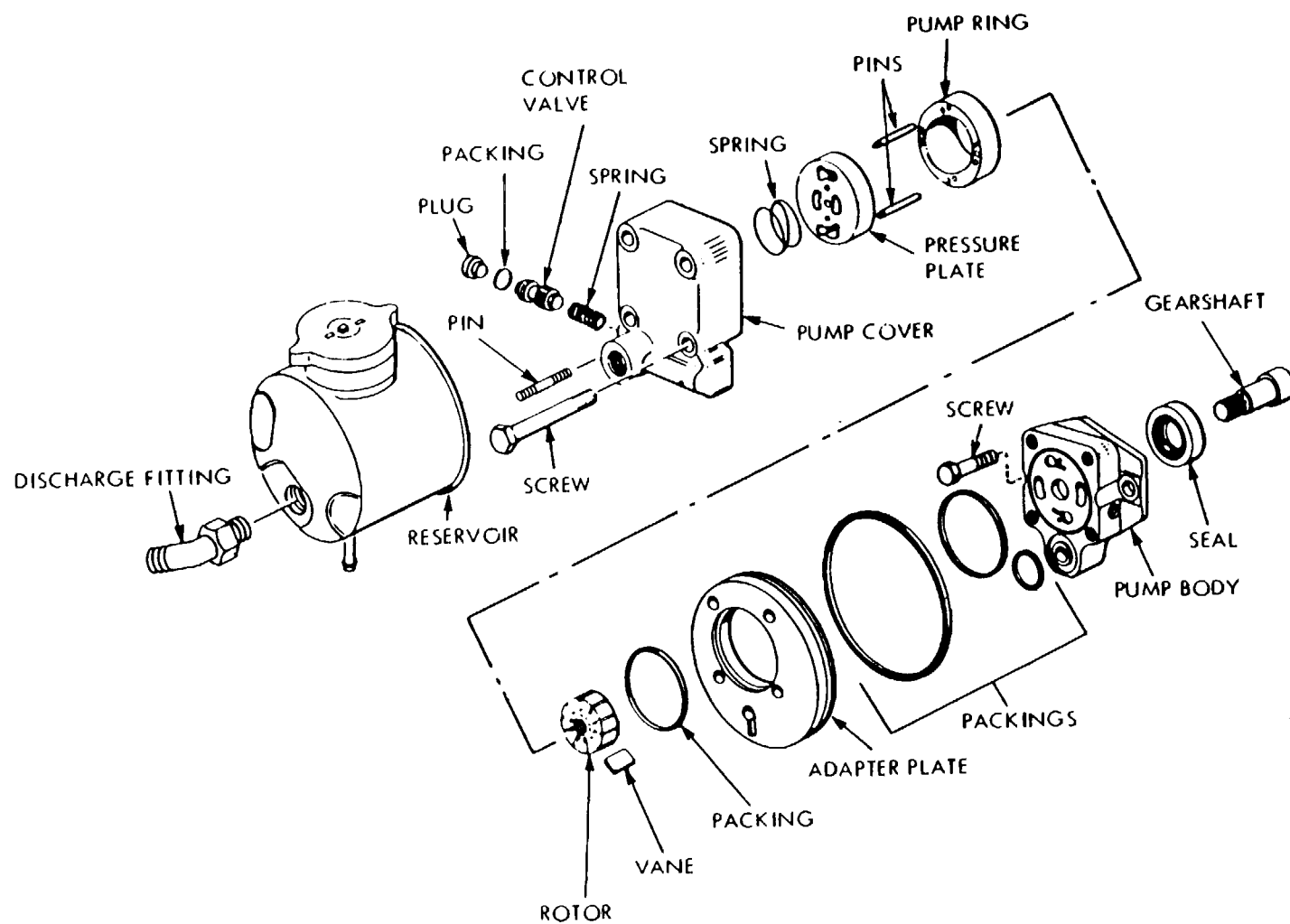

MEC 3930-256-35/27

Figure 27. Steering pump, exploded view.



- (5) Install the adapter plate and packings.
- (6) Oil the cartridge with clean oil OE and install pressure plate.
- (7) Install packing. Install pressure plate spring and cover. Tighten cover screws to 25 to 30 foot pounds torque.
- (8) Install pressure compensating spring in relief valve bore. Insert valve assembly with hex toward spring. Install plug with packing in bore and hold it in position while driving a new retaining pin.
- (9) Install pump mounting bolts in body flange. Install new packing on adapter

plate. Install reservoir so hole is aligned with cover discharge port. Install new packing on discharge fitting and install fitting to secure reservoir. Be careful that packing is not damaged as it is forced through hole in reservoir.

*f. Troubleshooting Assembled Pump.* The following Troubleshooting Chart is compiled on the basis of vane pump performance only. It lists possible difficulties that may be encountered and indicates probable cause and remedy. Crosscheck entries with Power Steering Troubleshooting Chart (para. 25m), if trouble occurs while pump is installed.

(1) *Pump not delivering oil.*

*Probable cause*

*Remedy*

Driven in wrong direction of rotation-----	Check direction of pump shaft rotation.
Pump drive shaft disengaged or sheared-----	Remove pump; determine damage to cartridge parts (see disassembly instruction) replace sheared shaft and needed parts.
Flow control valve stuck open -----	Disassemble pump and wash control valve in a clean solvent. Return valve to its bore and slide it back and forth. No stickiness in movement should occur. If a gritty feeling is noted on the valve od it may be polished with crocus cloth. Avoid removal of excess material or rounding of valve edges during this operation. Do not attempt to polish the valve bore. Wash all parts before reassembly of pump. Flush entire system thoroughly and fill with clean oil.
Vane or vanes stuck in rotor slots -----	Disassemble pump, examine rotor slots for dirt, grime or small metal chips. Clean rotor and vanes in SD, reassemble parts and check for free vane movement.
Oil viscosity too heavy to pick up prime -----	Use oil of the proper viscosity as recommended in LO 10-3930-256-20.
Pump intake partially blocked-----	Drain system completely; flush to clear pump passages. Flush and refill system with clean oil per recommendations.
Air vent for oil tank clogged or dirty strainer-----	Remove filler cap and clean air vent slot. Check filter or strainer in tank for clogged condition. Drain, flush and add clean oil to system if strainer was clogged.

(2) *Pump making noise.*

*Probable cause*

*Remedy*

Restricted or partially clogged intake line or clogged filter.	Pump must receive intake oil freely or cavitation will result. Drain system, and clean intake line and strainers. Add new oil, straining by recommended procedures.
Air leak at pump intake hose fittings or pump shaft seal.	Test by pouring oil on fittings and around drive shaft. Listen for change in operation. Tighten joints affected and replace pump drive shaft seal according to service instructions outlined in this paragraph.
Coupling misalignment -----	Re-align coupling, and replace oil seal and bearings if damaged by shaft misalignment.

Section VIII. HYDRAULIC LIFT COMPONENTS

29. Hydraulic Pump

a. Removal and Installation. Refer to TM 10-3930-256-20.

b. Disassembly.

(1) Remove screws and washers (fig. 28) holding pump assembly together. Draw cover from housing. Remove those bearings which are now accessible, and plate, packing, and gasket from cover. Discard packing and gasket.

- (2) Remove exposed retaining rings and take drive gear and driven gear from their shafts. Remove key from key-slot in drive shaft. Take second plate, gasket and packing from adapter.
- (3) Remove both gearshafts with remaining attached parts from adapter. Remove remaining driven gearshaft bearing and retaining ring.
- (4) From drive shaft, take outboard retaining ring, seat, seal, spring and washer. Discard seal. Remove remain-

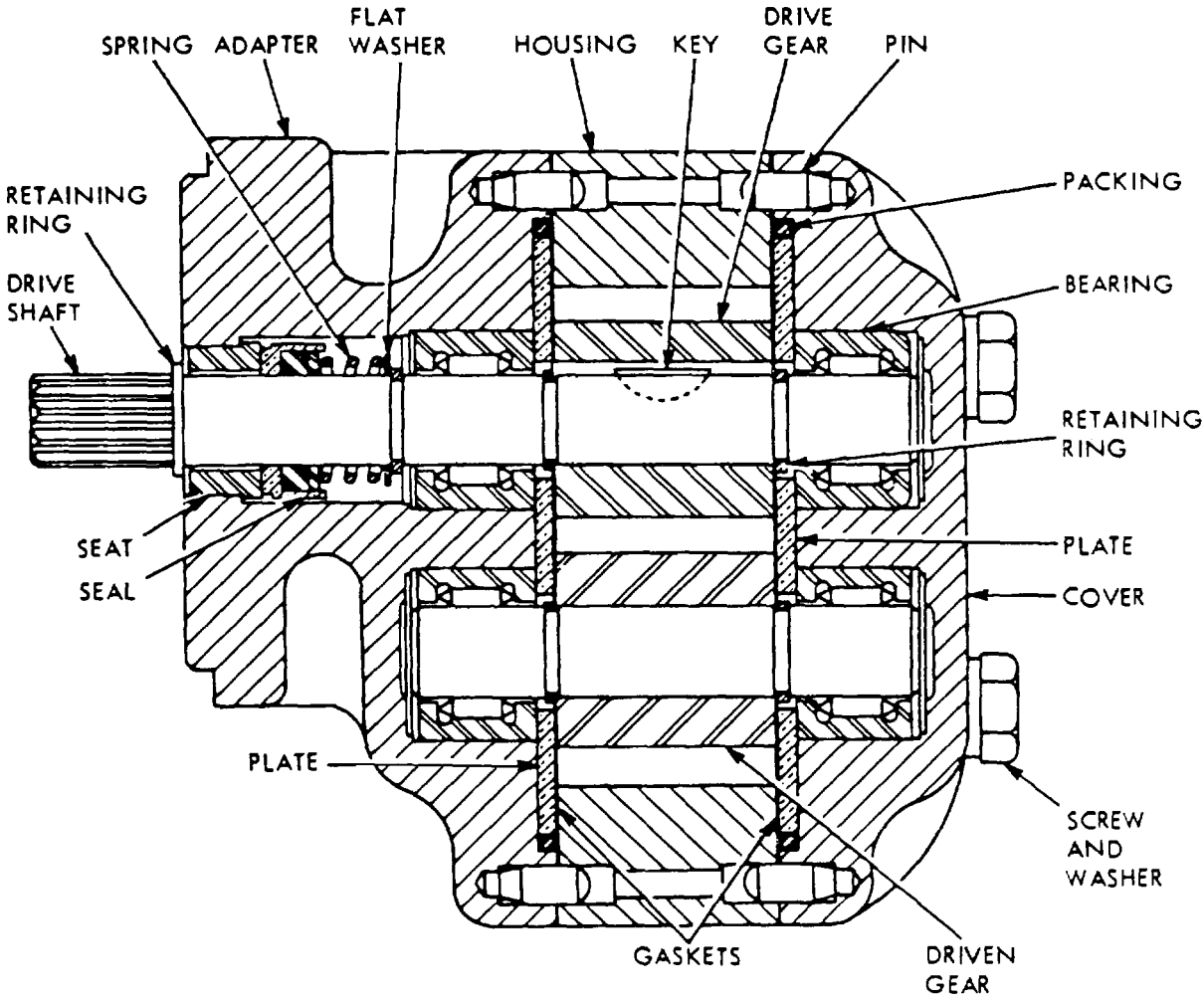

MEC 3930-256-35 / 2R

Figure 28. Hydraulic pump, cutaway view.

ing retaining rings and remaining drive shaft bearing.

- (5) Alignment pins, and retaining rings not interfering with disassembly need not be removed unless they are to be replaced.

c. *Cleaning and Inspection.*

- (1) Clean all parts with solvent SD, and dry with air before inspection.
- (2) Inspect pump shaft bearing surfaces for wear or damage. If bearing surface is imperfect replace shaft and related bearing at assembly.
- (3) Check fit of beatings on shaft, and in adapter and cover recesses for looseness. If fit at any point seems loose, substitute new parts until worn part causing looseness is identified. Replace worn parts at assembly.
- (4) Inspect mating surfaces of gear teeth for chipping or other visible damage. If one gear is damaged, replace both gears as a set.

d. *Assembly.*

- (1) Use all new nonmetallic parts at assembly.
- (2) Liberally oil all parts to be assembled, including nonmetallic parts.
- (3) Reverse *b* above to assembly.

### 30. Hydraulic Control Valve

a. *Removal and Installation.* Refer to TM 10-3930-256-20.

b. *Disassembly.*

- (1) Remove levers and linkage (TM 10-3930-256-20).
- (2) Unscrew plug (26, fig. 29) and seal (25). Remove nut (5), nut (4) and seals (7). Back out setscrew (6), and remove spring (10) and pilot plunger (11). Remove regulating valve cap (8) and packing (9).
- (3) Remove packing (13) and retainer (12), pilot seat (14), spring (15), poppet assembly (16), plunger (17) and seat (18).
- (4) Remove check valve cap (23) and

packing (24), spring (20) and poppet (19).

- (5) Remove screws (3) and brackets (2) from both TILT and HOIST valves. Remove wipers (1), packing retainers (39) and packing (38).
- (6) Take off both spool caps (31), and remove retaining rings (30 and 33), spring retainers (27 and 32), springs (29 and 34), and washers (28 and 35).
- (7) Remove packing retainers (22 and 36) and packings (21 and 37). Remove valve spools shown only for inspection and cleaning. They are not replacement items. Replace entire valve if spool is defective. Spools are not interchangeable. Replace each in its original position in valve.

c. *Cleaning, Inspection and Repair.*

- (1) Clean all parts in SD, and wipe thoroughly with a dry, lint-free cloth, or compressed air. Blow valve passages dry of SD.
- (2) Inspect all steel parts for rust spots or corrosion, scratches, and wear. Check threads for damage and repair those which show only moderate damage, with a tap or die.
- (3) Discard all nonmetal items removed during disassembly. All repairs to valve beyond thread repairs consist of installation of new parts to replace defective ones.

d. *Reassembly.*

- (1) Replace spools in valve body. Seat packings (21 and 37, fig. 29) in counterbore as shown and place packing retainers (22 and 36) over them. Assemble spring (34) and washer (35) within retainers (32), install over spool, and secure with retaining ring (33). Install spool cap (31). Repeat this procedure with corresponding parts at other spool.
- (2) Install packings (38) at top of each spool, packing retainers (39), and wipers (1). Install brackets (2) with screws (3).

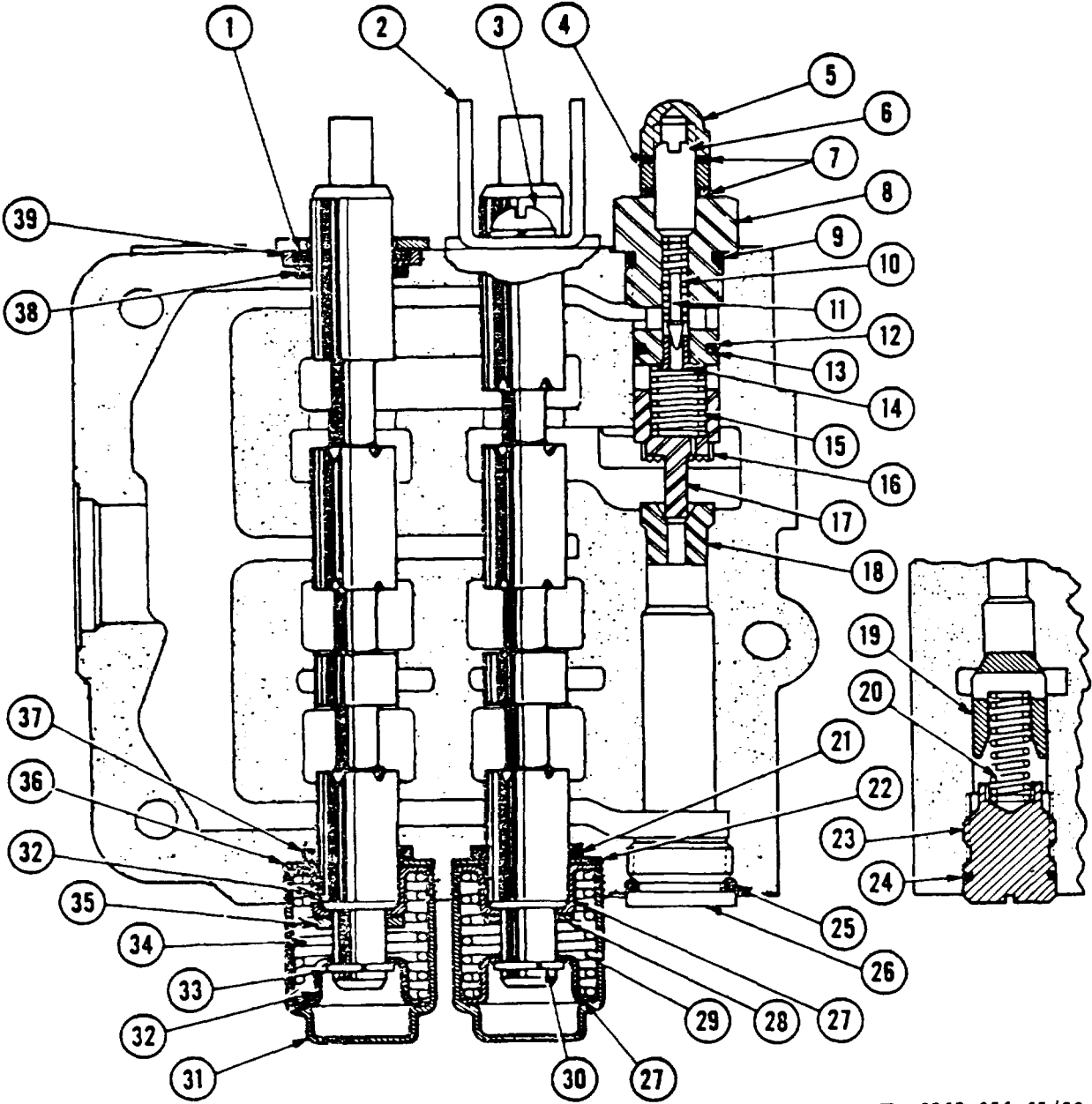

MEC 39 30-256-35 / 29

- |                        |                       |                     |                     |
|------------------------|-----------------------|---------------------|---------------------|
| 1 Wiper                | 11 Pilot plunger      | 21 Packing          | 31 Spool cap        |
| 2 Bracket              | 12 Retainer           | 22 Packing retainer | 32 Spring retainer  |
| 3 Screw                | 13 Packing            | 23 Check valve cap  | 33 Retaining ring   |
| 4 Nut                  | 14 Pilot seat         | 24 Packing          | 34 Spring           |
| 5 Nut                  | 15 Spring             | 25 Seal             | 35 Washer           |
| 6 Setscrew             | 16 Poppet assembly    | 26 Plug             | 36 Packing retainer |
| 7 Seal                 | 17 Plunger            | 27 Spring retainer  | 37 Packing          |
| 8 Regulating valve cap | 18 Plunger seat       | 28 Washer           | 38 Packing          |
| 9 Packing              | 19 Check valve poppet | 29 Spring           | 39 Packing retainer |
| 10 Spring              | 20 Spring             | 30 Retaining ring   |                     |

Figure 29. Hydraulic control valve, cutaway view.

- (3) Place packing (24) on check valve cap (23). Install poppet (19), spring (20) and cap and packing.
- (4) Press plunger seat (18) into position, install plunger (17) and poppet assembly (16), spring (15), and pilot seat (14). Put packing (13) on retainer (12) and install retainer.
- (5) Position pilot plunger (11), and spring (10). Put packing (9) on cap (8) and install cap.
- (6) Install setscrew (6), seals (7) and nut (4). Install nut (5), and install handles and linkage by reversing a above.

*e. Adjustment.*

- (1) With valve installed on truck, and all hoses connected, disconnect LIFT hose at valve.
- (2) At valve LIFT port, install a hydraulic pressure gage calibrated to test 0 to 3000 psi.
- (3) Operate LIFT control handle to operate regulator valve. Note gage reading. Valve must relieve at 1750 to 1850 psi. To adjust, remove nut (5), loosen nut (4), and turn setscrew (6) clock-wise to raise setting or counterclock-wise to lower setting. Tighten locknut and replace cap nut (5), remove gage and replace LIFT hose.

*f. Installation.* Reverse procedure in *b* above.

### 31. Hydraulic Tilt Cylinders

*a. Removal and Installation.* (TM 10-3930-25620).

*b. Repair.* Repair of tilt cylinders is accomplished by installation of new parts to replace defective items found during disassembly.

*c. Disassembly.*

- (1) Remove nut (1, fig. 30), washer (2) and screw (13). Remove rod end (14) from piston and rod (11).
- (2) Remove screw (3), washer (4) and retainer (6). Remove wiper ring (5) and packing (7). Unscrew stuffing box (8) from cylinder (12), take out piston and rod (11), and remove packings (9 and 10) from piston.

*d. Assembly.*

- (1) Install packings (9 and 10, fig. 30) on piston (11), and install in cylinder (12). Screw stuffing box (8) snugly into cylinder with a pin spanner wrench.
- (2) Position packing (7) in stuffing box and install packing retainer (6) with screws (3) and washers (4) only tightly enough to prevent seepage of fluid. This item can be further tightened later after installation of the cylinder if necessary to stop leakage.
- (3) Install wiper ring (5) on piston rod, replace rod end (14), screw (13), washer (2) and nut (1).

### 32. Lift Cylinder (130 Inch Lift)

*a. Removal.*

- (1) Drain hydraulic system oil (LO 10-3930-256-20).
- (2) Disconnect cylinder hydraulic line, and adapter (42, fig. 31) from regulator valve (41).
- (3) Remove chain assemblies (TM 10-3930-256-20) from crosshead.
- (4) Remove nut (1) from top of lift cylinder (46). Raise and brace inner upright (52) to clear lift cylinder and remove cylinder from truck.

*b. Disassembly.*

- (1) Clamp lift cylinder in vise equipped with V-shaped jaws. Remove screws (1, fig. 32) and washers (2). Unscrew packing nut (7) from primary plunger (28). Remove wiper ring (6), packing (4) and packing assembly (9).
- (2) Unscrew packing nut (11) from cylinder (27). Remove ring (10) and packing retainer (12) and packing assembly (26).
- (3) Slide plunger (28) from primary cylinder (27) and remove guide (14) and retaining ring (13).
- (4) Unscrew packing nut (18) from cylinder (25). Remove ring (17), packing retainer (19), and packing assembly (20). Slide cylinder from plunger (24). Remove bearing (21) from cylinder.

- (5) Remove packing (16) and washer (15) from cylinder. Unscrew cylinder end (3) and remove packing (4), washer (5) and plunger (24). Remove bearings (21 and 23).

c. *Cleaning, Inspection and Repair.*

- (1) Clean all metal parts with SD.
- (2) Inspect all tubular sections for dents or bends. Check all friction surfaces for roughness, pits or other irregularities. Discard all nonmetal parts.
- (3) Repair moderate damage to threaded holes, with a tap. Remove minor roughness on friction surfaces by honing, followed by thorough recleaning to remove traces of abrasive.

d. *Assembly.*

- (1) Install bearings (21 and 23, fig. 32) on secondary plunger (24).
- (2) Install secondary plunger in secondary cylinder (25), place packing (4) and washer (5) on end of cylinder and install cylinder end (3). Install bleeder screw (1) and washer (2) in cylinder, end.
- (3) Install packing (16) and washer (15) in groove on secondary cylinder. Replace packing assembly (20), retainer (19), packing nut (18) and wiper ring (17).
- (4) Install plunger guide (14) and retaining ring (13) in bore of primary plunger (28). Install items assembled in (1) to (3) above in primary plunger, then install primary cylinder over this assembly, and screw secondary cylinder into primary cylinder.
- (5) Install bleeder screw (1) and washer (2) in primary cylinder. Install wiper ring (10) in packing nut (11), and install packing assembly (26), packing retainer (12) and retain with packing nut (11).
- (6) Install packing assembly (9), retainer (8) and nut (7).

e. *Installation.* Reverse the procedure in *a* above. Bleed air from cylinder by removing both bleeder screws (1, fig. 32), from cylinder,

and pressurizing cylinder until oil appears at the bleed holes. Replace screws after bleeding cylinders.

**33. Crosshead Assembly (130 Inch Lift)**

a. *Removal.*

- (1) Remove lift chains (TM 103930-256-20).
- (2) Remove nut (1, fig. 31). Raise inner upright (52) to clear lift cylinder (46) and lift off crosshead (52) assembly.

b. *Disassembly.* Remove retaining rings (47, fig. 31), washers (48), bearings (49), and rollers (50).

c. *Assembly.* Pack bearings and rollers with GAA, and reverse *b* above.

d. *Installation.* Reverse *a* above.

**34. Inner Upright Assembly (130 Inch Lift)**

a. *Removal.*

- (1) Remove nut (1, fig. 31).
- (2) Remove screws (25), spacers (21), and lock washers (24) attaching latch assemblies within carriage; remove latch assemblies. Raise and block up inner upright.
- (3) Slide roller assemblies from lift carriage (7). Remove rollers (12) and bearings (10). Slide washers (11) and shims (9) from carriage. Disconnect lift chains from carriage and remove carriage.
- (4) Remove screws (3) and lowering plates (2).
- (5) Remove screws (35) attaching inserts (38) to outer upright (26); remove inserts.
- (6) Remove screws (30) and lockwashers (31) attaching strikers (32). Remove strikers and spacers (33).
- (7) Slide inner upright (52) up, and out of outer upright (26).

b. *Installation.* Pack bearings (10, fig. 31) with GAA, and liberally apply GAA to the sliding surfaces of inner and outer uprights, then reverse *a* above.

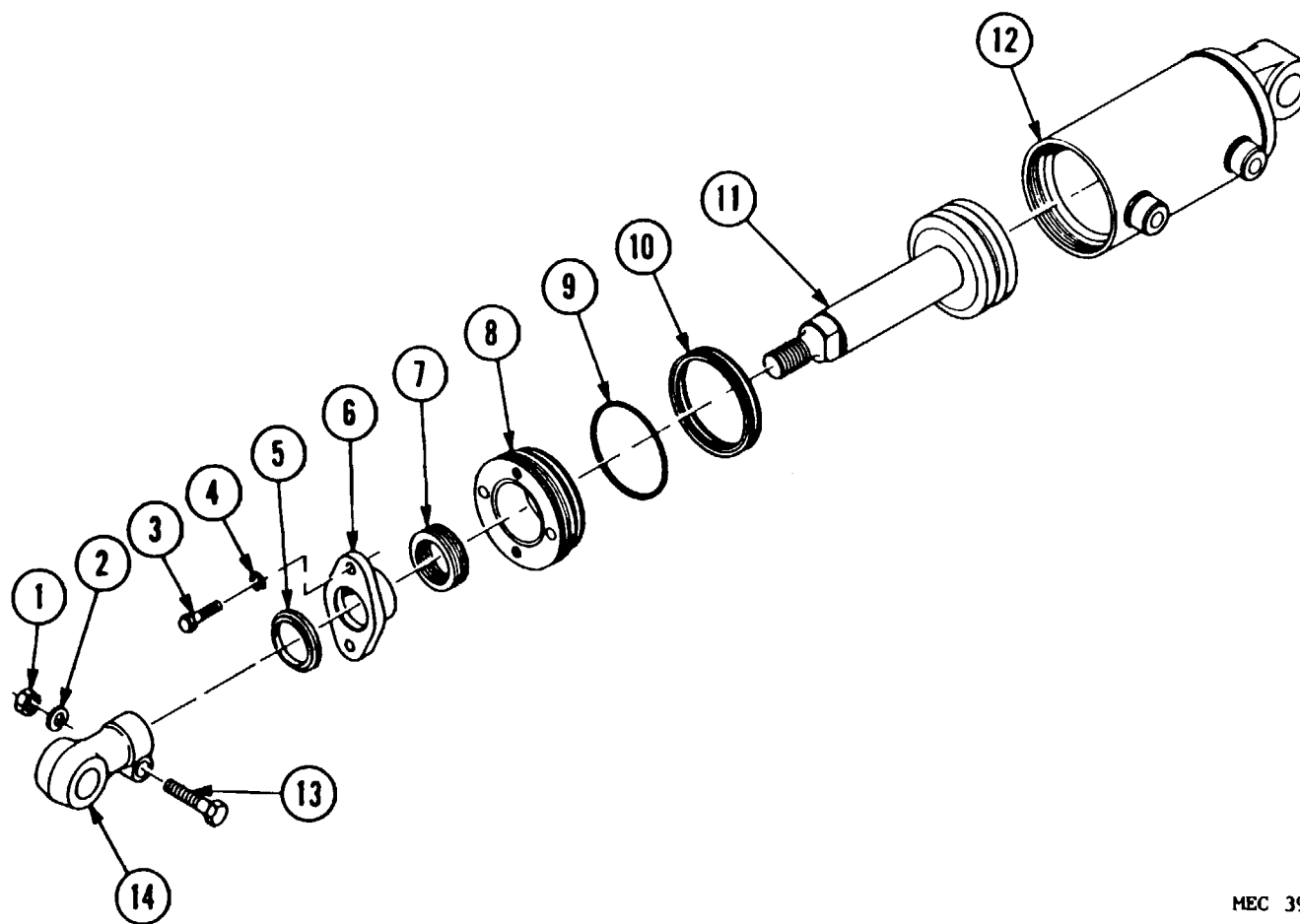

MEC 3930-256-35/30

- |          |          |                    |                |            |                   |            |
|----------|----------|--------------------|----------------|------------|-------------------|------------|
| 1 Nut    | 3 Screw  | 5 Wiper ring       | 7 Packing      | 9 Packing  | 11 Piston and rod | 13 Screw   |
| 2 Washer | 4 Washer | 6 Packing retainer | 8 Stuffing box | 10 Packing | 12 Cylinder       | 14 Rod end |

AGO 8176A

Figure 30. Tilt cylinder, exploded view.

**35. Lift Cylinder (172 Inch Lift)**

*a. Removal*

- (1) Remove lift chains (TM 10-3930-25-20).
- (2) Disconnect hydraulic hose from flow restrictor (44, fig. 33) at base of lift cylinder. Cap hose to keep out dirt.
- (3) Remove screws (20), washers (19), bracket (18), nut (17), tube (16) and pulldown rod (1).
- (4) Remove screws and washers which attach crosshead to lift cylinder (fig. 33). Raise crosshead free of cylinder.
- (5) Remove cylinder from position in bottom member of outer upright and remove flow regulator and both elbows from base of cylinder.

*b. Disassembly.*

- (1) Remove wiper ring, packing retainer, packing set and sleeve bushing (fig. 34) from lift cylinder.
- (2) If leakage is apparent, remove screw and gasket.

*c. Assembly.* Reverse *b* above, tightening packing retainer just snugly enough to prevent leakage.

*d. Installation.*

- (1) Reverse *a* above.
- (2) Loosen screw (fig. 34) enough to release trapped air slowly, and operate lift cylinder until hydraulic fluid free of air bubbles leaks from around screw.
- (3) Tighten screw and test operation of

---

1 Nut	19 Washer	37 Setscrew
2 Lowering plate	20 Screw	38 Outer upright insert
3 Screw	21 Spacers	39 Ball
4 Load backrest	22 Screw	40 Pipe nipple
5 Spacer	23 Plate	41 Elbow and flow restrictor
6 Fork support shaft	24 Washer	42 Fitting
7 Lift carnage	25 Screw	43 Nuts
8 Shim	26 Outer upright	44 Chain adjustment screw
9 Shim	27 Angle bracket	45 Chains
10 Bearings	28 Washer	46 Lift cylinder
11 Retaining ring	29 Screw	47 Retaining ring
12 Roller	30 Screw	48 Washer
13 Pin	31 Washer	49 Roller bearing
14 Bolt	32 Striker latch	50 Bearing roller
15 Shim	33 Spacer	51 Crosshead
16 Spring	34 Insert shim	52 Inner upright
17 Forks	35 Screw	
18 Shaft lock plate	36 Headless screw	

*Figure 31. Mast assembly (130 inch lift), exploded view.*



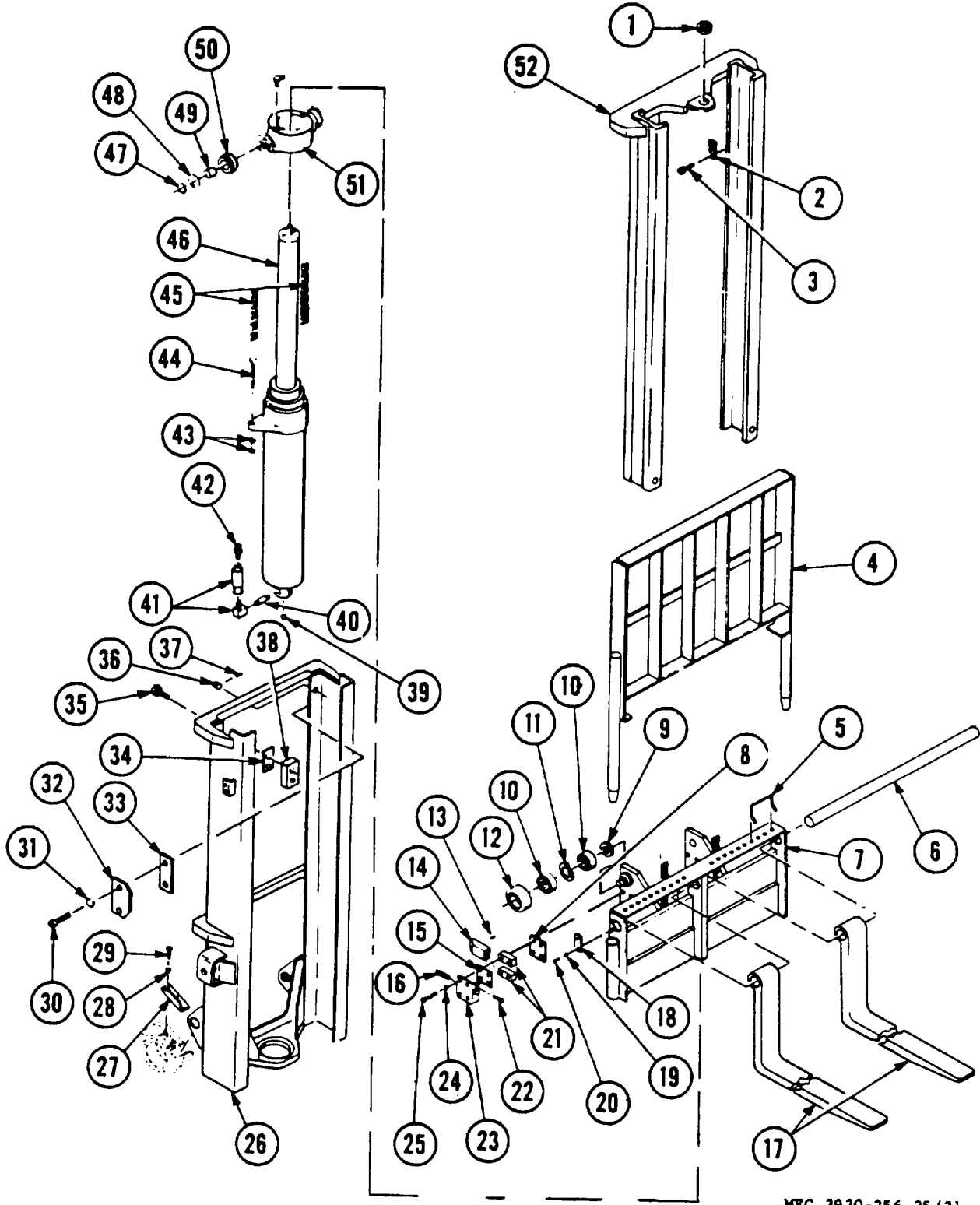

MEC 3930-256-35/31

Figure 31. Mast assembly (130 inch lift), exploded view-Continued.

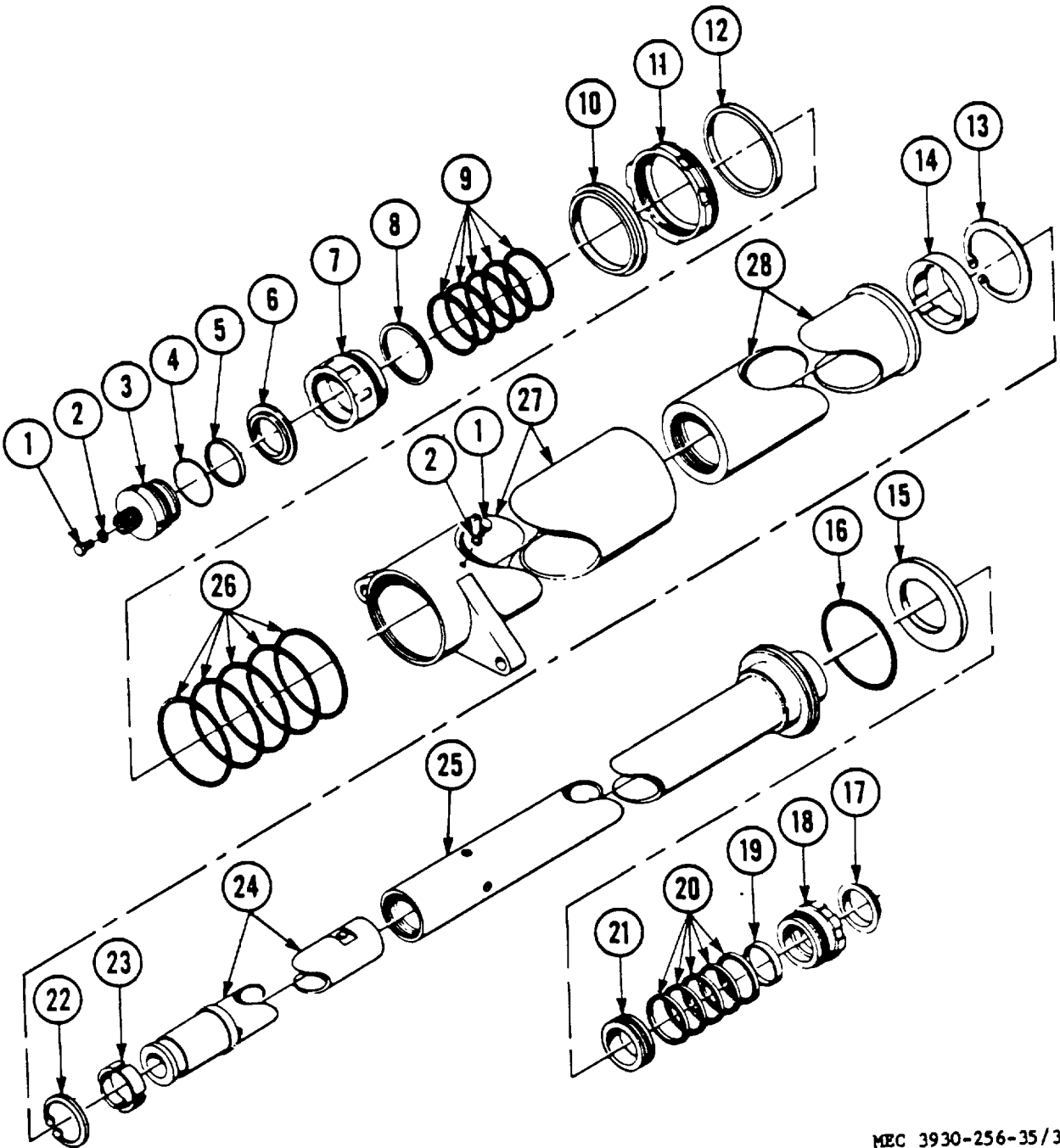

MEC 3930-256-35/32

- |                 |                     |                     |                       |
|-----------------|---------------------|---------------------|-----------------------|
| 1 Bleeder screw | 8 Packing retainer  | 15 Washer           | 22 Retaining ring     |
| 2 Washer        | 9 Packing assembly  | 16 Packing          | 23 Sleeve bearing     |
| 3 Cylinder end  | 10 Wiper ring       | 17 Wiper ring       | 24 Secondary plunger  |
| 4 Packing       | 11 Packing nut      | 18 Packing nut      | 25 Secondary cylinder |
| 5 Washer        | 12 Packing retainer | 19 Packing retainer | 26 Packing assembly   |
| 6 Wiper ring    | 13 Retaining ring   | 20 Packing assembly | 27 Primary cylinder   |
| 7 Packing nut   | 14 Plunger guide    | 21 Sleeve bearing   | 28 Primary plunger    |

Figure 32. Lift cylinder (130 inch lift), exploded view.

cylinder. If fluid leaks around packing, tighten packing retainer only enough to stop leak.

**36. Crosshead, Inner Upright, and Carriage Assembly**

- a. *Removal.* Refer to paragraph 13a(1).
- b. *Disassembly.*
  - (1) Remove chains (TM 10-3930-256-20).
  - (2) Remove lift cylinder (para. 35a).
  - (3) Lift off load back rest (21, fig. 33).
  - (4) Raise inner upright (12) slightly, loosen nut (17) at bottom of guide rod (1) and unscrew rod from bracket (18) on inner upright. Remove rod, tube (16), nut, and bushing within crosshead (48). Lift crosshead from cylinder.
  - (5) Refer to paragraph 33 for complete crosshead service instructions.
  - (6) Remove screws (20, fig. 33) and washers (19) attaching bracket (18) to inner upright (12) and remove bracket.
  - (7) Remove screws (32), washers (33), and carriage bar (31) from carriage (23). Remove forks (36). Lift carriage out of inner upright.
  - (8) Remove roller assemblies (30) and shims (29) from carriage trunnions.
  - (9) Remove plugs (10) and setscrews

(11), and remove inner upright from within outer upright (42).

- c. *Repair.*
  - (1) Repair damaged threaded items by cleaning up threads with a tap or die.
  - (2) Straighten slightly deformed structural items by cold bending.
  - (3) Replace any damaged elements not readily repaired by procedures in (1) or (2) above.
- d. *Assembly.*
  - (1) Reverse procedures in *b* above.
  - (2) Bleed air from lift cylinder (para. 35d (2)).

**37. Hydraulic Oil Tank**

- a. *Removal.*
  - (1) Raise truck high enough to clear oil tank at removal, and provide access to attaching parts.
  - (2) Drain oil from tank (LO 10-3930-256-20).
  - (3) Loosen hose clamp (fig. 35) and disconnect hose between tank and filter.
  - (4) Disconnect pump suction line at tank (refer to Suction Filter Cartridge Replacement in TM 10-3930-256-20).
  - (5) Remove screws and washers (fig. 35), and take tank from truck.
- b. *Installation.* Reverse *a* above, and fill tank with oil as instructed in LO 10-3930-256-20.

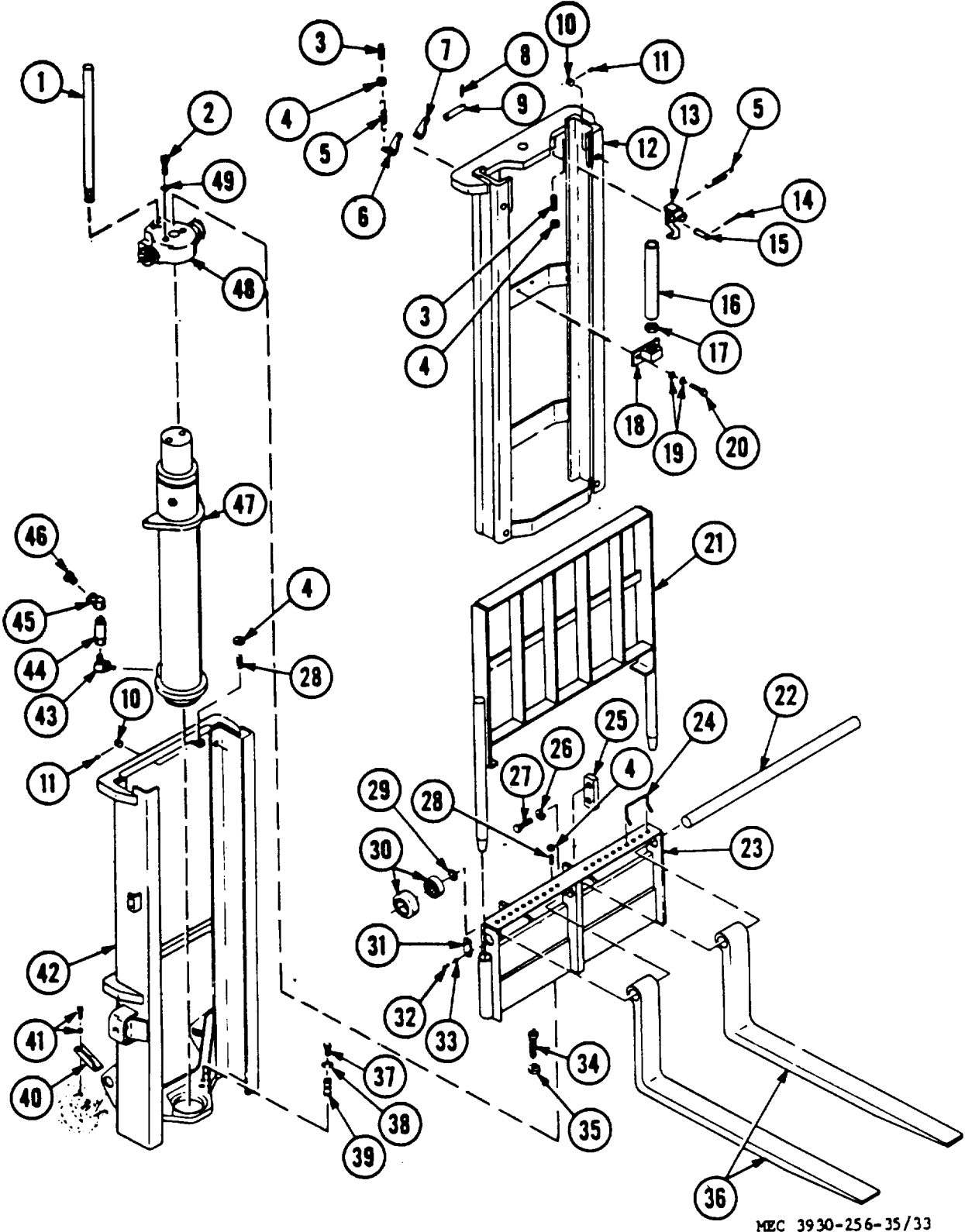

M2C 3930-256-35/33

Figure 33. Mast assembly (172 inch lift), exploded view.

- |    |                          |    |                       |
|----|--------------------------|----|-----------------------|
| 1  | Upright guide rod        | 26 | Washer                |
| 2  | Screw                    | 27 | Screw                 |
| 3  | Lever setscrew           | 28 | Setscrew              |
| 4  | Sleeve bushing           | 29 | Retaining ring        |
| 5  | Spring                   | 30 | Bearing and roller    |
| 6  | Right hand upright lever | 31 | Fork shaft lock plate |
| 7  | Left hand upright lever  | 32 | Screw                 |
| 8  | Spring pin               | 33 | Washer                |
| 9  | Straight shaft           | 34 | Chain anchor          |
| 10 | Headless screw           | 35 | Nut                   |
| 11 | Setscrew                 | 36 | Forks                 |
| 12 | Inner upright            | 37 | Screw                 |
| 13 | Upright lever hook       | 38 | Washer                |
| 14 | Cotter pin               | 39 | Plate                 |
| 15 | Shaft                    | 40 | Angle' bracket        |
| 16 | Tube                     | 41 | Screw and washer      |
| 17 | Nut                      | 42 | Outer upright         |
| 18 | Pulldown rod bracket     | 43 | Elbow                 |
| 19 | Washers                  | 44 | Flow restrictor       |
| 20 | Screw                    | 45 | 45° angle fitting     |
| 21 | Load backrest            | 46 | Adapter bushing       |
| 22 | Fork shaft               | 47 | Lift cylinder         |
| 23 | Lift carriage            | 48 | Crosshead assembly    |
| 24 | Fork spacer              | 49 | Washer                |
| 25 | Carriage spacer bar      |    |                       |

Figure 33. Mast assembly (172 inch lift), exploded view-Continued.

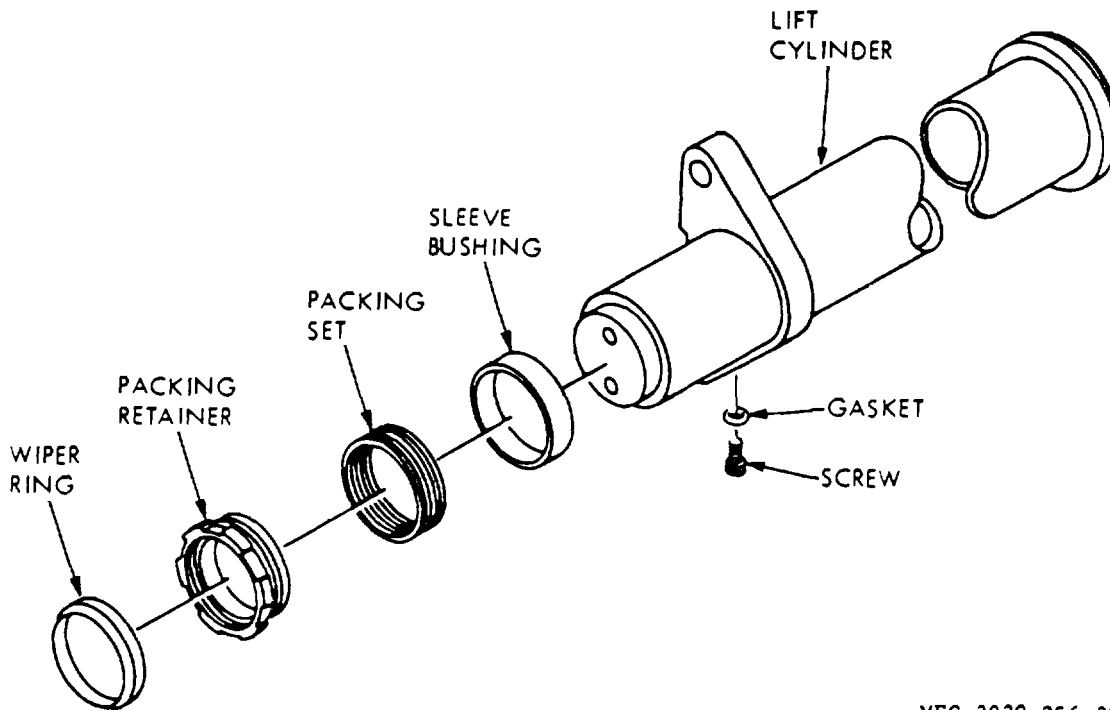

MEC 3930-256-35/34

Figure 34. Lift cylinder (172 inch lift), exploded view.

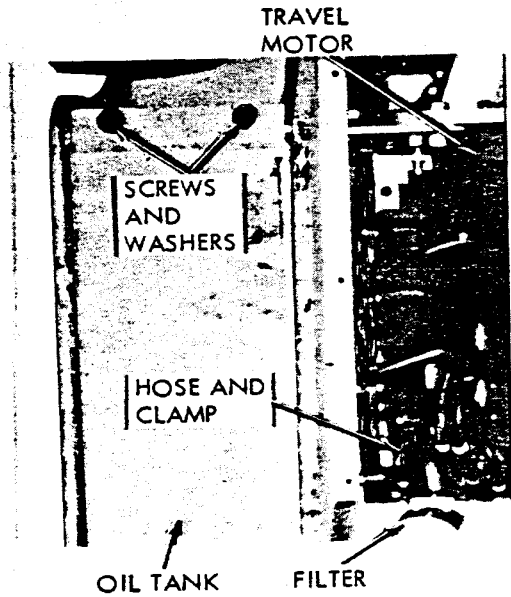

MEC 3930-256-35 / 35

Figure 35. Oil tank removal.

**Section IX. ELECTRIC MOTORS**

**38. General**

The three motors on the truck are series wound dc motors. The travel motor and hydraulic pump motor are similar, except for size, and provision for parking brake mounting and rotation reversal on the travel motor. The following general procedures apply to all three motors. They will not be repeated subsequently.

*a. Inspection.*

- (1) With motor on test operation for five minutes, observe for bearing heating,

unusual noises from bearings or brushes, and vibration.

- (2) Observe action of brushes on commutator. Excessive sparking of brushes indicates worn brushes, weak brush springs, defective armature or commutator.
- (3) Note length of brushes at inspection by comparison with new replacement brush. Replace any brush worn to less than half the length of new brush.

1	Bearing retainer	12	Insulator	23	Screw	34	Nut	45	Field coil
2	Washer	13	Washer	24	Fan	35	Washer	46	Nut
3	Bearing	14	Electrical lead	25	Shield	36	Screw	47	Washer
4	Pole piece screw	15	Brush holder	26	Washer	37	Insulator	48	Washer
5	Frame	16	Insulator	27	Nut	38	Washer	49	Drive end bell
6	Insulator	17	Terminal nut	28	Screw	39	Washer	50	Washer
7	Washer	18	Washer	29	Screw	40	Screw	51	Screw
8	Screw	19	Washer	30	Washer	41	Brush spring	52	Washer
9	Armature	20	Washer	31	Dust seal	42	Brush	53	Screw
10	Screw	21	Screw	32	Brush end bell	43	Pole piece		
11	Washer	22	Cover	33	Washer	44	Insulator		

Figure 36. Travel motor, exploded view.

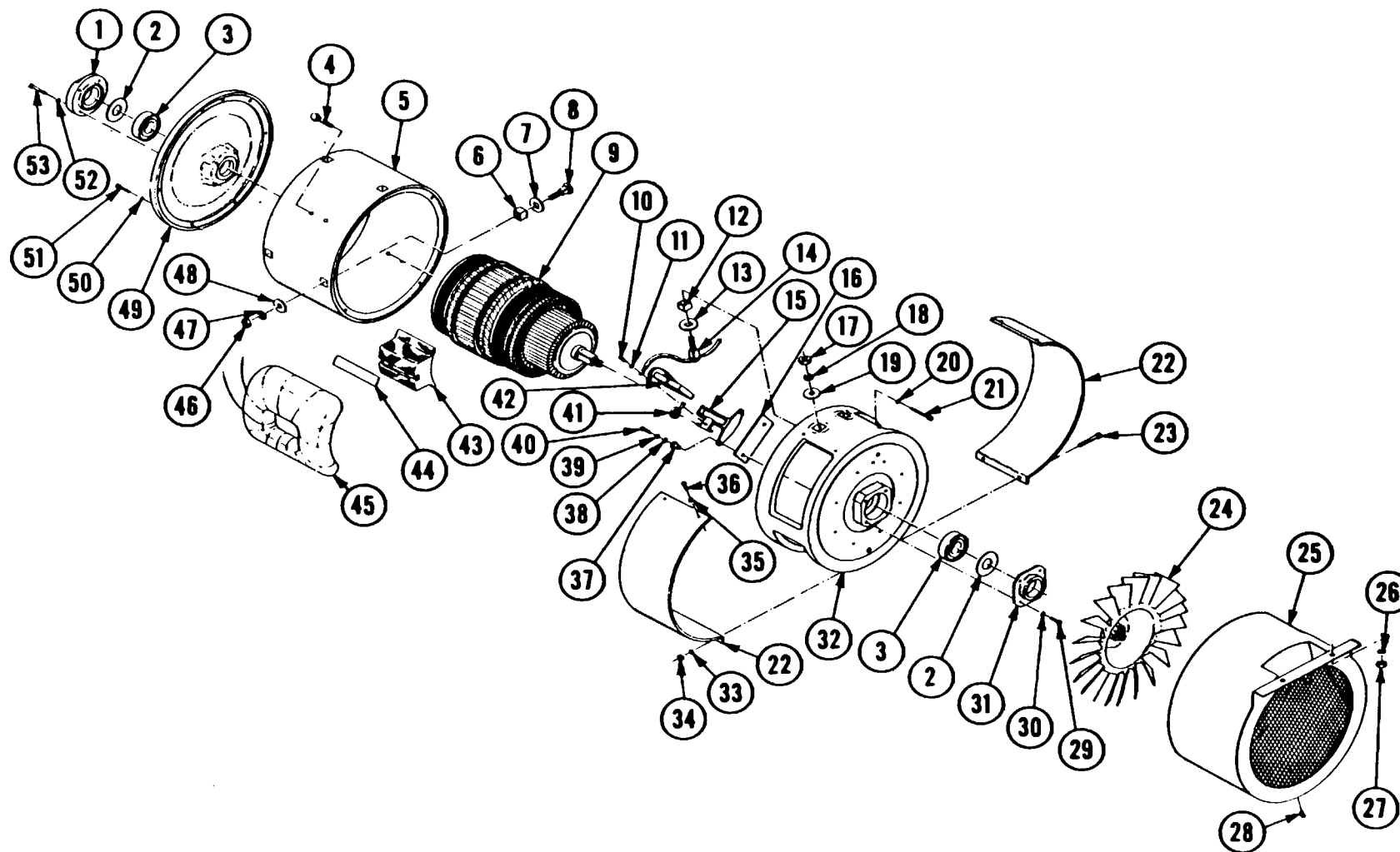

MEC 39 30-25 6-35 / 36

Figure 36. Travel motor, exploded view-Continued

- (4) Inspect interior of motors and brush inspection covers for thrown solder, indicating overheating in operation.

*b. Cleaning.*

- (1) Before disassembly, wipe exterior with a cloth moistened with SD.
- (2) Remove as much dirt as practical from parts with compressed air.
- (3) Wipe remaining dirt from parts with a cloth slightly moistened with SD. Do not wet armature or field windings.
- (4) Clean commutators to bright finish with 00 or finer sandpaper, or commutator stone. Do not use emery cloth.

*c. Lubrication.* Lubricate unsealed bearings with grease, GAA. Do *not* try to lubricate sealed bearings.

*d. Repair.* Repair of all motors is limited to soldering loose solder joint connections, truing commutators, in a lathe, and replacing defective parts.

*e. Run-in.* Run-in new brushes with motors unloaded, at 12 to 16 volts dc only. Higher voltage could cause overspeeding, and armature destruction.

**39. Travel Motor**

*a. Removal.* Refer to paragraph 13a.

*b. Installation.*

- (1) Perform paragraph 15d, (2) and (3).
- (2) Reverse *a* above.

*c. Disassembly.* Disassemble only as far as necessary to repair, as follows:

- (1) Remove screws (36 and 23, figure 36), washers (33 and 35), nuts (34), and take off covers (22).
- (2) Disconnect leads (14) at brush holders (15). Remove brushes (42) from

motor. Unscrew fan (24) from shaft of armature (9).

- (3) Remove screws (53) and washers (52). Take off end bell (49). Remove screws (53), washers (52), bearing retainer (1), washer (2) and bearing (3).
- (4) Remove socket head screws (21) and separate frame (5), armature (9) and end bell (32). Take nut (17), washers (13, 18, and 19), insulator (12) and leads (41) from end bell.
- (5) Remove screws (4) to free pole pieces (43), insulators (44) and field coils (45).

*d. Inspection, Cleaning, Lubrication and Repair.* Refer to paragraph 38, for general instructions. Additionally,

- (1) If balancing machine is available, check armature dynamic balance to be within 1 inch ounce, at 3000 revolutions per minute.
- (2) Measure commutator run out. If in excess of 0.002 inch total indicator reading, turn in lathe, truing commutator within above limits, and holding copper surface smoothness to less than 33 microinches. This finish may be obtained, after lathe turning, with fine sandpaper or commutator stone.
- (3) Check brush length of used brushes by comparing them with new brush. If brushes have less than 2/3 length of new brushes, replace them, as they will not last until next regular disassembly.

*e. Assembly.* Reverse *c* above.

*f. Test After Assembly.*

- (1) Separately excite the field with rated current (100 amps), making terminal S1 positive and terminal S2 negative.

---

1	Commutator end bell	8	Insulator	15	End bell	22	Screw
2	Brush spring	9	Insulator	16	Bolt	23	Bearing
3	Brush	10	Washers	17	Washer	24	Screw and washer
4	Screw	11	Nuts	18	Field winding	25	Spacer yoke and brush holders
5	Brush access cover	12	Armature	19	Pole piece	26	Bolt and washer
6	Terminal screw	13	Woodruff key	20	Screw		
7	Washer	14	Bearing	21	Field frame		

Figure 37. Hydraulic pump motor, exploded view.



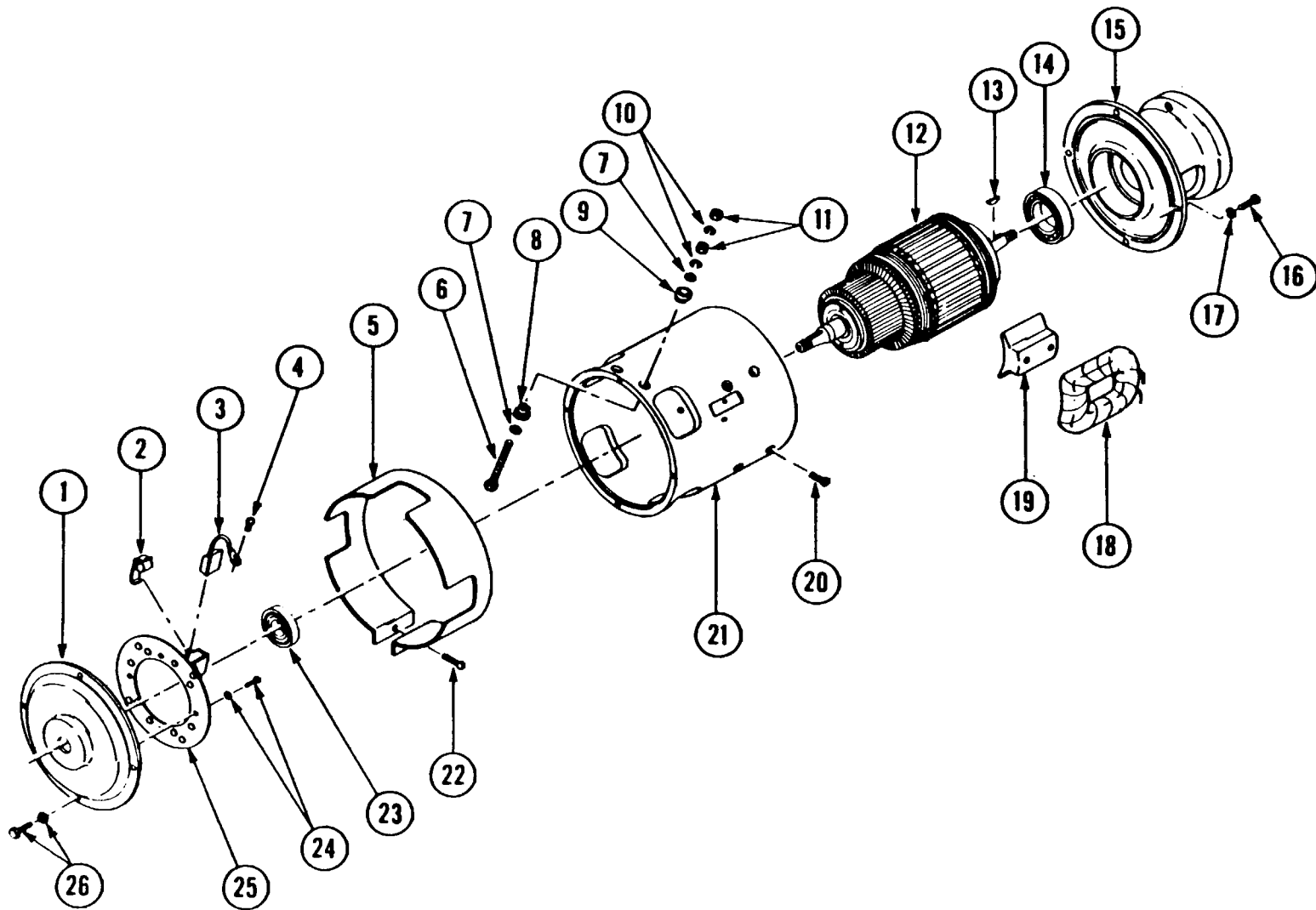

MEC 3930-256-35/37

Figure 37. Hydraulic pump motor, exploded view-Continued.

- (2) Seat brushes, and run motor with rated voltage on armature terminals, making A2 positive and A1 negative. Armature must now turn clockwise, viewed from commutator end.
- (3) After brushes have been seated and motor has run for four minutes, record speed, armature current and voltage, and field current. Observe commutator and brushes for sparking at this time.
- (4) Make a high potential test above ground on all windings, using 600 volts ac for one second, or 500 volts ac for one minute.

**40. Hydraulic Pump Motor**

*a. Removal and Installation.* Refer to TM 10-3930-256-20.

*b. Disassembly.* Disassemble only as far as necessary, as follows:

- (1) Remove screw (22, fig. 37), and brush access cover (5). Press down on each brush spring (2) to unhook it at the bottom, and remove brush springs. Remove screws (4) and brushes (3).
- (2) Remove screws and washers (26) and take off end bell (1) with spacer yoke (25). Remove screws and washers (24), and yoke.
- (3) Remove armature (12), and bearings (14 and 23).
- (4) Remove screws (16), washers (17), and take end bell (15) from field frame (21).
- (5) Remove nuts (11), washers (7 and 10), insulators (8), and terminal screws (6) from field frame.
- (6) Remove screws (20), pole piece (19), and field windings (18).

*c. Inspection.*

- (1) Refer to paragraph 38a.
- (2) With motor assembled, check that

brush spring tension is between 26 and 32 ounces.

*d. Cleaning.* Refer to paragraph 38b.

*e. Assembly.* Reverse *b* above.

*f. Test After Assembly.*

- (1) Refer to TM 10-3930-256-20.
- (2) Make a test connection to a brush holder 90 mechanical degrees from the brush holder connected to terminal A1.
- (3) From an independent source separately excite the series field at 57.5 amperes, making test connection positive, and S2 negative.
- (4) From a separate independent power source apply rated voltage to armature, making A1 positive and test connection negative. Seat brushes and run motor. Rotation should be clockwise, viewed from commutator end.
- (5) Make a high potential test above ground on all windings, using 600 volts ac for one second, or 500 volts ac for one minute.

**41. Steering Motor**

*a. Removal and Installation.* Refer to TM 10-3930-256-20.

*b. Disassembly.* Disassemble only as far as necessary, as follows:

- (1) Remove screw (1, fig. 38) and fan guard (2). Remove setscrew (3) and take fan (4) from motor. Relieve pressure of brush springs (9) on brushes (10) and remove brushes.

**Caution: Do not pull brushes out by leads, if brushes might be serviceable. Leads may be damaged.**

- (2) Remove screws from both end bells (7 and 14). Take end bells from field frame (16). Remove armature (13) from field frame.

---

1	Screw	8	Brush frame	15	Bearing
2	Fan guard	9	Brush springs	16	Frame
3	Setscrew	10	Brushes	17	Field coils
4	Fan	11	Washer	18	Lockwasher
5	Bracket	12	Washer	19	Nut
6	Bearing	13	Armature	20	Washer
7	Brush end bell	14	Drive end bell	21	Screw

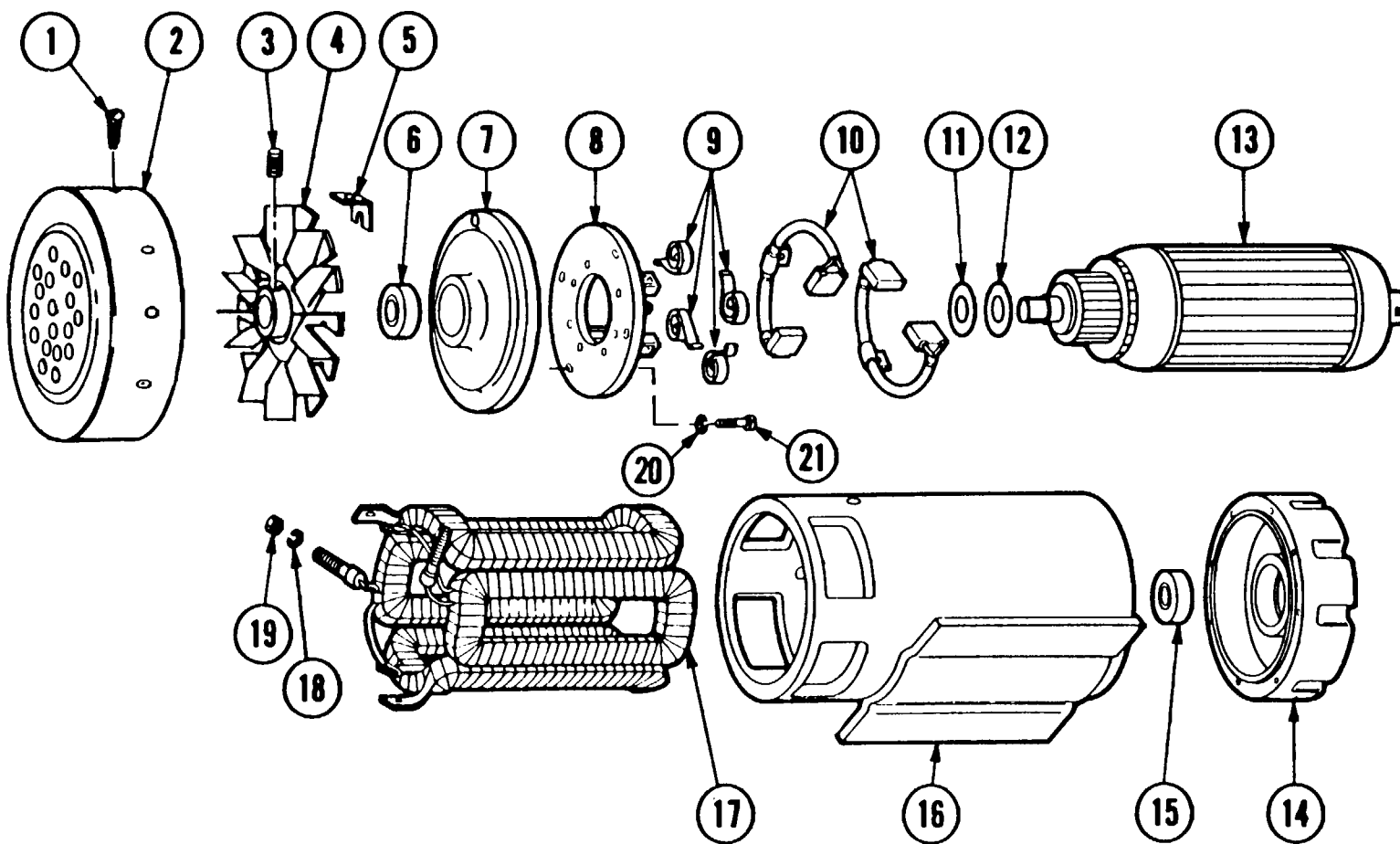
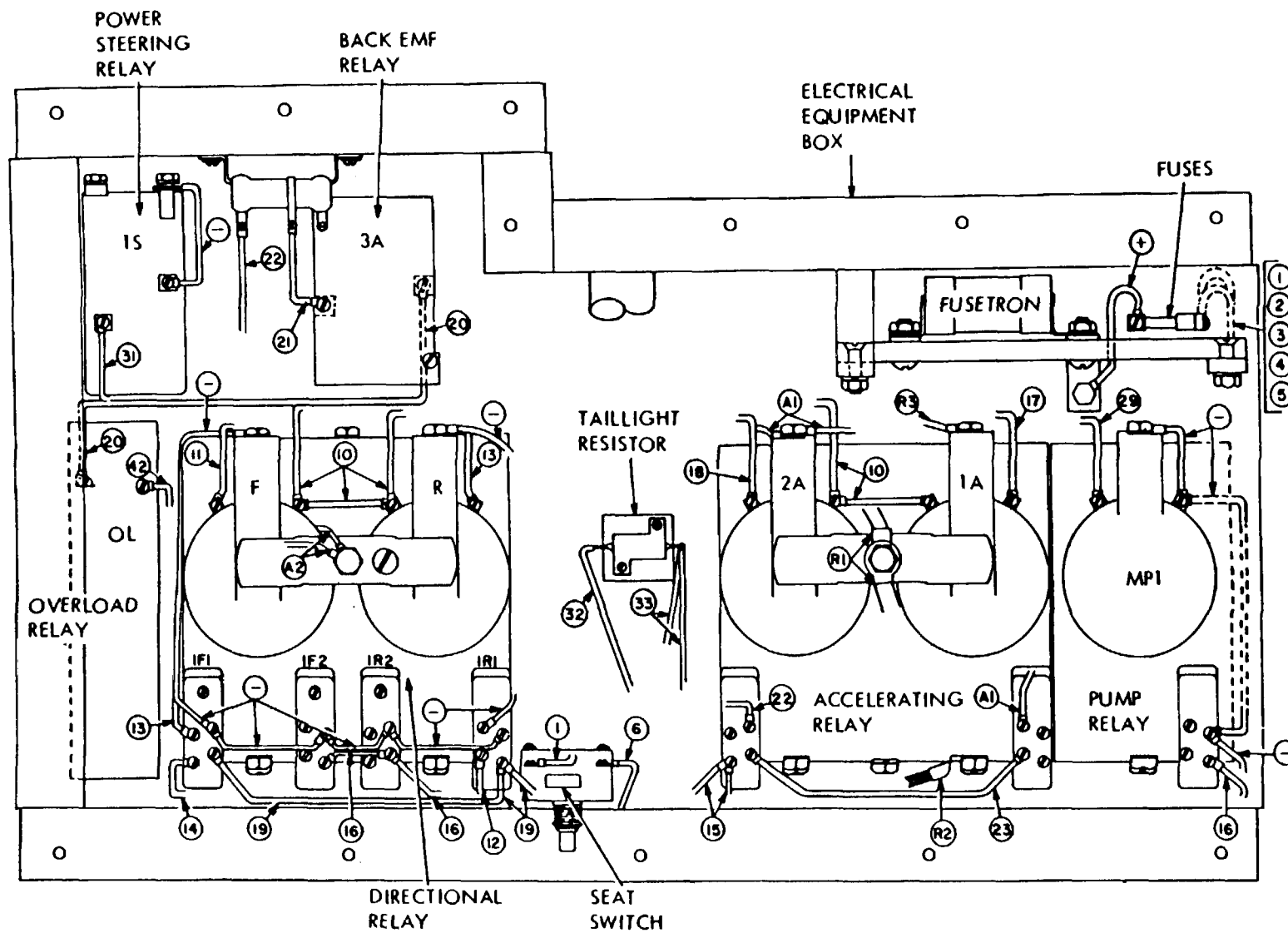

FIG. C 3930-256-35/38

Figure 38. Steer pump motor, exploded view-Continued.



MEC 3930-256-35/39

Figure 39. Electrical equipment box, and wire labels.

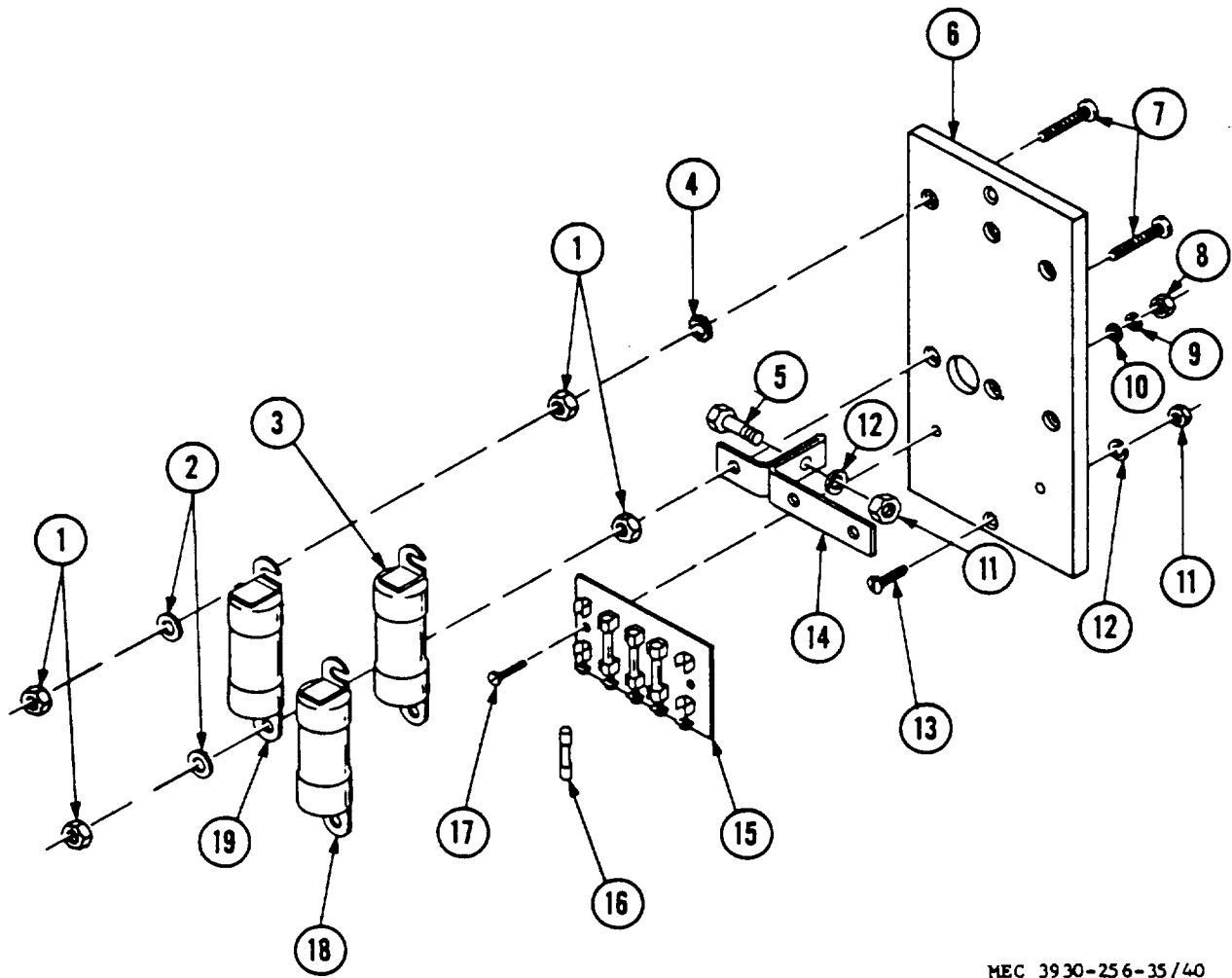

MEC 3930-256-35/40

1	Nuts	6	Fuseholder	11	Nut	16	Fuse (14 a. rating)
2	Washers	7	Screws	12	Lockwasher	17	Screw
3	Fuse	8	Nut	13	Screw	18	Fuse
4	Washer	9	Lockwasher	14	Bus bar	19	Fuse
5	Screw	10	Flat washer	15	Fuseholder		

Figure 40. Fuseholder assembly, exploded view.

(3) Remove screws (21), washers (20), and take brush holder (8) from commutator end bell. If they are to be replaced, take bearings (6 and 15) from end bells.

c. *Inspection.* Refer to paragraph 38a.

d. *Cleaning.* Refer to paragraph 38b.

e. *Repair.* Refer to paragraph 38d.

f. *Assembly.* Reverse b above.

g. *Test After Assembly.* Refer to TM 10-3930-256-20.

#### 42. Electrical Equipment Box Cover

a. *Removal.*

- (1) Remove truck cowl (TM 10-3930-256-20).
- (2) Remove cover screws (fig. 39) and cover.

b. *Installation.* Reverse a above.

**43. Relays**

All relays are housed in the electrical equipment box (fig. 39). All are attached to the box with thread cutting screws and washers. Removal and installation procedures for all relays are the same.

*a. Removal.*

- (1) Remove electrical equipment box cover (par. 42a).
- (2) Disconnect electrical leads to relay.  
*Note.* Disconnect only those leads which prevent removal of relay. Do not remove any conductor which is a component of a relay.
- (3) Remove thread cutting screws and washers, and take relay from electrical equipment box.

*b. Installation.* Referring to figure 39 for guidance in connecting leads, reverse *a* above. Circled designators on figure 39 correspond to circuit identification labels on wires at terminals.

**44. Fuseholder Assembly**

Refer to figure 39 for location of fuseholder assembly.

*a. Removal and Disassembly.*

- (1) Remove electrical equipment box cover (para. 42a).
- (2) Remove cover over fuses (TM 10-3930-25620).
- (3) Disconnect leads from bus bar (14).
- (4) Remove nuts (11, fig. 40), washers (12), and screw (13), and remove

- fuseholder assembly from equipment box.
- (5) Remove nuts (8), washers (9 and 10), screws (17) and take fuseholder (15) for small fuses from larger fuseholder (6).

*b. Assembly and Installation.* Reverse *a* above.

**45. Directional Switch**

*a. Removal and Installation.* Refer to TM 10-3930-256-20.

*b. Contact Replacement.*

- (1) Remove screws (3, fig. 41), washers (4), and cover (2).
- (2) Press contact fingers (8) together, rotate them one-fourth turn, and take them from contact carrier (10).
- (3) Remove screws holding terminal boards (5 and 6). Remove terminal boards with contacts.
- (4) Install new contacts by reversing (1) to (3) above.

*c. Switch Disassembly.* Disassemble only as far as necessary to repair, as follows:

- (1) Perform steps (1) to (3) above.
- (2) Remove springs (19, fig. 41). Remove clips and screws (15), hinge pins (16), and roller arm assemblies (18).
- (3) Remove screw (13) and washers (11 and 12), then take operating shaft (17), bushing (9), and contact carrier (10) from housing (14).

*d. Switch Assembly.* Reverse *c* above.

---

1 Knob	8 Contact fingers	15 Retaining clip and screw
2 Cover	9 Bushing	16 Hinge pin
3 Screw	10 Contact carrier	17 Operating shaft
4 Washer	11 Washer	18 Roller arm assembly
5 Terminal board	12 Washer	19 Handle return springs
6 Terminal board	13 Screw	20 Lever
7 Contact spring	14 Housing	21 Screw

Figure 41. Directional switch, exploded view.

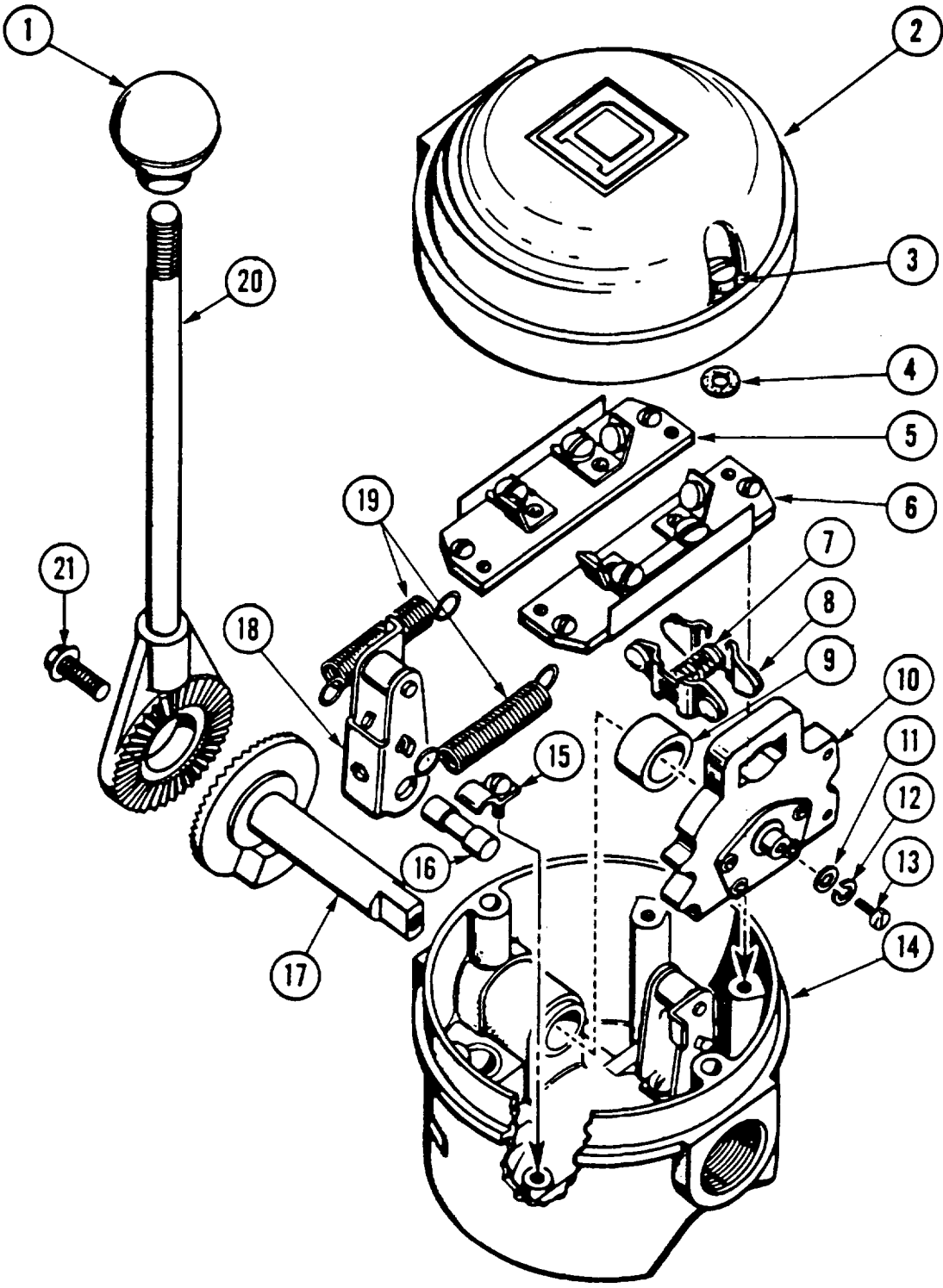

MEC 3930-256-35/41

Figure 41. Directional switch, exploded view-Continued

## APPENDIX I REFERENCES

---

AR 320-5-----	Dictionary of United States Army Terms.
AR 320-50-----	Authorized Abbreviations and Brevity Codes.
AR 700-3900-5-----	Registration of Materials Handling Equipment and Special Purpose Vehicles.
AR 700-58-----	Report of Damaged or Improper Shipment.
AR 746-5-----	Color and Marking of Materiel.
AR 750-3900-1-----	Materials Handling Equipment.
AR 750-5-----	Organization, Policies and Responsibilities for Maintenance Operation.
DA Pam 108-1-----	Index of Army Motion Pictures, Film Strips, Slides, and Phono Recordings.
DA Pam 310-1-----	Military Publications: Index of Administrative Publications.
DA Pam 310-2-----	Military Publications: Index of Blank Forms.
DA Pam 310-3-----	Military Publications: Index of Training Publications.
DA Pam 310-4-----	Military Publications: Index of Technical Manuals, Technical Bulletins. Supply Manuals (types 4, 6, 7, 8, and 9), Supply Catalogs (type CL), Supply Bulletins, Lubrication Orders, and Modification Work Orders.
FM 21-30-----	Military Symbols.
FM 21-5-----	Military Training Management.
FM 21-6-----	Techniques of Military Instruction.
LO 10-3930-256-20-----	Lubrication Order; Truck, Lift, Fork, Electric, Solid Rubber Tired Wheels, 6000 Pound Capacity, Army Model MHE-198, Baker Model FTD-060-EE, Federal Stock Number 3930-724-4057 (130 in. lift), Federal Stock Number 3930-724-4059 (172 in. lift).
MIL-STD-162A-----	Preparation for Delivery of Warehouse Materials Handling Equipment for Domestic and Oversea Shipment and Storage.
SB 5-111-----	Supply of DA Approved Fire Extinguishers to Army Troop Users.
TM 9-213-----	Painting Instructions for Field Use.
TM 10-3930-256-10-----	Operator's Manual; Truck, Lift, Fork, Electric, Solid Rubber Tired Wheels, 6000 Pound Capacity, Army Model MHE-198, Baker Model FTD-060-EE, Federal Stock Number 3930-724-4057 (130 in. lift), Federal Stock Number 3930-724-4059 (172 in. lift).
TM 10-3930-256-20-----	Organizational Maintenance Manual; Truck, Lift, Fork, Electric, Solid Rubber Tired Wheels, 6000 Pound Capacity, Army Model MHE-198, Baker Model FTD-060-EE, Federal Stock Number 3930-724-4057 (130 in. lift), Federal Stock Number 3930-724-4059 (172 in. lift).
TM 10-3930-256-20P-----	Organizational Maintenance Repair Parts and Special Tools List; Truck, Lift, Fork, Electric, Solid Rubber Tired Wheels, 6000 Pound Capacity. Army Model MHE-198, Baker Model FTD-060-EE, Federal Stock Number 3930-724-4057 (130 in. lift), Federal Stock Number 3930- 724-4059 (172 in. lift).
AGO 8176A	



TM 10-3930-256-35P-----	Direct and General Support and Depot Maintenance Repair Parts and Special Tools List: Truck, Lift, Fork, Electric, Solid Rubber Tired Wheels, 6000 Pound Capacity, Army Model MHE-198, Bakrd Model FTD-060-EE, Federal Stock Number 3930-724-4057 (130 in. lift) Federal Stock Number 3930-724-4059 (172 in. lift).
TM 21-300-----	Driver Selection and Training (Wheeled Vehicles).
TM 38-230-----	Preservation, Packaging, and Packing of Military Supplies and Equipment.
TM 38-750-----	Army Equipment Records Procedures.
TM 5-764 -----	Electric Motor and Generator Repair.
TM 10-1690A -----	Industrial Motive Power Storage Batteries for Materials Handling Equipment.

AGO 8176A

**APPENDIX II**  
**MAINTENANCE ALLOCATION**

---

Maintenance Allocation Chart is published in TM 10-3930-256-20.

AGO 8176A

APPENDIX III

REPAIR PARTS AND SPECIAL TOOL LISTS

---

Repair parts and special tool lists is published in TM 10-3930-25-35P.

AGO 8176A

APPENDIX IV

DIRECT AND GENERAL SUPPORT MAINTENANCE SUPPORT OF ORGANIZATIONAL LEVEL SERVICE ON RECEIPT OF NEW EQUIPMENT (TM 10-3930-256-20)

On receipt of a new truck, the using organization will require the assistance of maintenance facilities with welding capability, for initial installation of battery retaining parts shipped loose with truck. Refer to Basic Issue Item Lists in TM 10-3939-25610 for part numbers of these parts. Locate two angles to suit dimensions of battery installed. Weld and assemble parts as shown in figure 42.

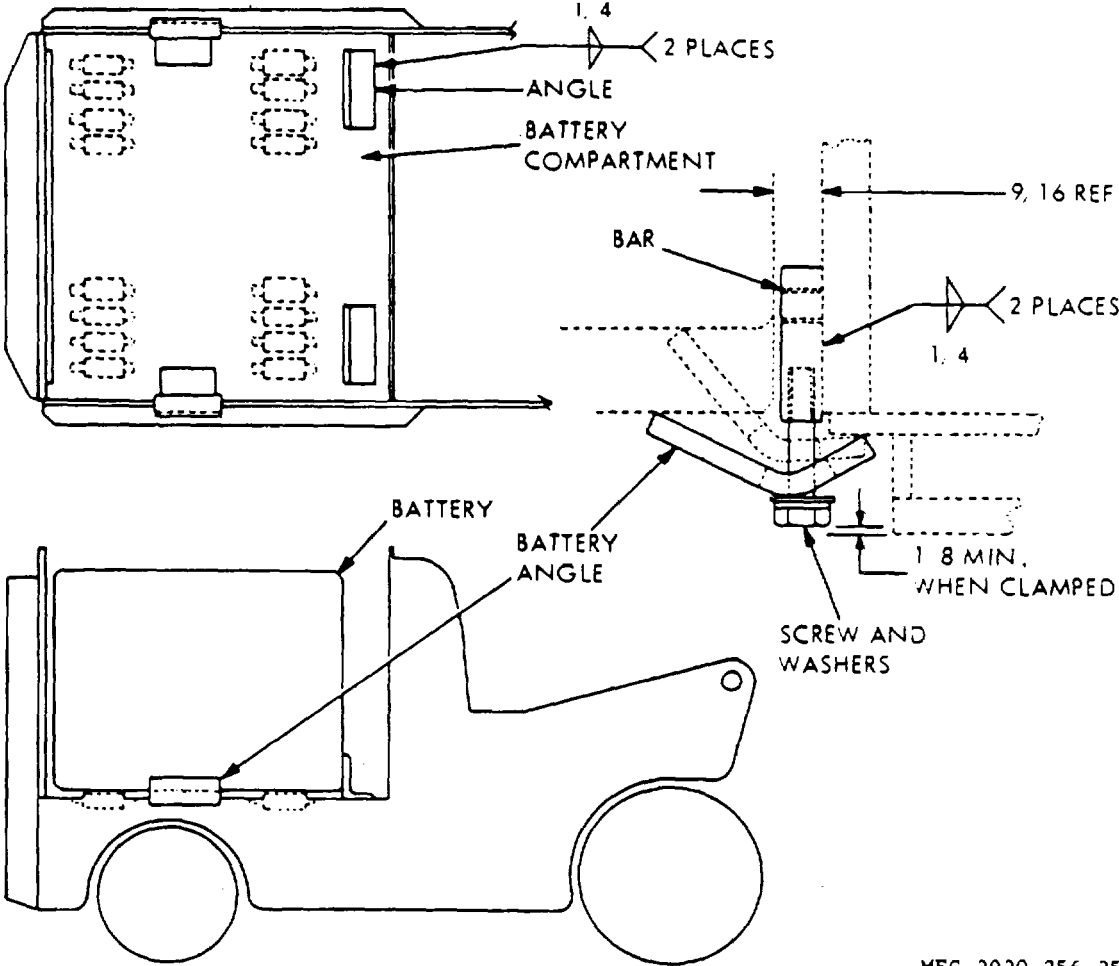

MEC 3930-256-35/42

Figure 42. Installation drawing, battery retaining parts.

By Order of the Secretary of the Army:

HAROLD K. JOHNSON,  
*General, United States Army,  
Chief of Staff.*

Official:

J. C. LAMBERT,  
*Major General, United States Army,  
The Adjutant General.*

Distribution:

*Active Army:*

USASA (1)  
DCSLOG (1)  
CNGB (1)  
CAR (1)  
CofEngrs (6)  
CofSptS (1)  
Dir of Trans (1)  
CC-E (1)  
USCONARC (2)  
USAMC (12)  
ARADCOM (2)  
ARADOM Rgn (2)  
OS Maj Comd (3)  
LOGCOMD (1)  
USAMOCOM (2)  
USAWECOM (5)  
USAMICOM (5)  
USAMUCOM (5)  
USAECOM (5)  
USATECOM (5)  
USASMC (1)  
MDW (1)

Armies (5)  
Instl (2)  
USMA (1)  
Br Svc Sch (2) except  
    USAQMS (10)  
Army Dep (4)  
NLABS (4)  
USA Mob Equip Cen (46)  
USAQMTC (4)  
Mob Equip Manuals Fld Ofc (Ft Lee) (2)  
POE (2)  
USA Tml Comd (2)  
Army Tml (2)  
Arsenals (2)  
PG (2)  
QM Fld Maint Shops (2)  
Units org under fol TOE:  
    8-187 (2)  
    9-367 (2)  
    10-337 (2)  
    10-407 (2)  
    10-467 (2)

NG: State AG (3).

USAR: None.

For explanation of abbreviations used, see AR :320-50.

\*U.S. GOVERNMENT PRINTING OFFICE: 1975-579-377/365

U.S. ARMY ADJUTANT GENERAL PUBLICATIONS CENTER, ST. LOUIS, MO, 1995

AGO 8176A

**This page only for NON-SOFTWARE-related TM errors/improvements.**

RECOMMENDED CHANGES TO EQUIPMENT TECHNICAL PUBLICATIONS



*THEN...JOT DOWN THE DOPE ABOUT IT ON THIS FORM. CAREFULLY TEAR IT OUT. FOLD IT AND DROP IT IN THE MAIL.*

**SOMETHING WRONG WITH THIS PUBLICATION?**

FROM: (PRINT YOUR UNIT'S COMPLETE ADDRESS)

DATE SENT

PUBLICATION NUMBER

PUBLICATION DATE

PUBLICATION TITLE

BE EXACT PIN-POINT WHERE IT IS

PAGE NO.	PARA-GRAPH	FIGURE NO.	TABLE NO.
----------	------------	------------	-----------

IN THIS SPACE TELL WHAT IS WRONG AND WHAT SHOULD BE DONE ABOUT IT:

TEAR ALONG PERFORATED LINE

PRINTED NAME GRADE OR TITLE AND TELEPHONE NUMBER

SIGN HERE

DA FORM 2028-2  
1 JUL 79

PREVIOUS EDITIONS ARE OBSOLETE

P.S.—IF YOUR OUTFIT WANTS TO KNOW ABOUT YOUR RECOMMENDATION MAKE A CARBON COPY OF THIS AND GIVE IT TO YOUR HEADQUARTERS



This fine document...

Was brought to you by me:



## [Liberated Manuals -- free army and government manuals](#)

Why do I do it? I am tired of sleazy CD-ROM sellers, who take publicly available information, slap “watermarks” and other junk on it, and sell it. Those masters of search engine manipulation make sure that their sites that sell free information, come up first in search engines. They did not create it... They did not even scan it... Why should they get your money? Why are not letting you give those free manuals to your friends?

I am setting this document FREE. This document was made by the US Government and is NOT protected by Copyright. Feel free to share, republish, sell and so on.

I am not asking you for donations, fees or handouts. If you can, please provide a link to [liberatedmanuals.com](http://liberatedmanuals.com), so that free manuals come up first in search engines:

<A HREF=<http://www.liberatedmanuals.com/>>Free Military and Government Manuals</A>

- Sincerely  
Igor Chudov  
<http://igor.chudov.com/>
- [Chicago Machinery Movers](#)