

TECHNICAL MANUAL

**OPERATOR'S
AVIATION UNIT
AND INTERMEDIATE
MAINTENANCE MANUAL
(INCLUDING REPAIR PARTS
AND SPECIAL TOOLS LIST)**

**FOR
HYDRAULIC KNEELING/ERECTING CART
P/N: 10064-10
NSN: 4320-01-345-0478**

DISTRIBUTION STATEMENT A Approved for public release, distribution is unlimited

Headquarters, Department of the Army

30 September 1992

WARNING

WARNING SUMMARY

Personnel performing operations, procedures, and practices which are included or implied in this technical manual shall observe the following instructions. Disregard of these warnings may result in serious or fatal injury to personnel.

CHECKING HOSES AND HOSE DISCONNECTS

High hydraulic fluid pressures are developed during cart operation. The connecting hoses must be free of defects and the hose disconnects clean to avoid hose rupture or leaks.

To prevent injury and damage to equipment due to strut collapse and helicopter rollover, insure that hydraulic line is properly routed to prevent fouling. Route hydraulic line down through the access cover on top of the forward avionics bay (FAB) walkway to the landing gear kneeling nipple.

To prevent injury and damage to equipment due to strut collapse and helicopter rollover, do not force quick disconnect on to strut kneeling valve nipple. Difficulty in connecting quick disconnect may indicate strut collar is unlocked and if forced, the quick disconnect may fail. If difficulty is experienced, lack helicopter (TM 55-1520-238-23) to relieve pressure before proceeding.

USE OF CLEANING SOLVENT

Use volatile solvents only in a well ventilated area. Avoid prolonged contact with skin.

GENERAL MAINTENANCE

Be sure that all electrical power is removed from the unit before beginning any maintenance operation.

GENERAL MAINTENANCE (Continued)

To avoid personnel injury, the pump must be shut down before beginning any maintenance operation.

SERVICING FILTER

Test cart must be shut down before servicing filter.

OPERATION

To prevent injury and equipment damage from strut collapse and helicopter rollover, hydraulic lines must be properly connected. The cart operator stands in front of and facing the helicopter. Connecting the left hose to the right strut and the right hose to the left strut will avoid confusion during kneeling and erecting operations. The LEFT switch on the controller will operate the landing gear on the operators left. The RIGHT switch on the controller will operate the landing gear on the operators right.

To prevent injury and equipment damage from strut collapse and helicopter rollover, personnel will be thoroughly familiar with procedures contained in this chapter prior to conduction kneeling or erecting operations.

To prevent injury and equipment damage from strut collapse and helicopter rollover, personnel will remain clear of helicopter during kneeling or erecting operations.

To prevent injury from possible helicopter rollover, keep struts as close to the same length as possible during kneeling and erecting operations.

To prevent injury and equipment damage from strut collapse and helicopter rollover, do not proceed until all leaks are repaired.

OPERATION (Continued)

To prevent injury and equipment damage from strut collapse and helicopter rollover, ensure that there is no strut movement after closing shutoff valves. Strut movement indicates a leaking shutoff valve that must be replaced prior to shipment.

**OPERATOR'S AVIATION UNIT AND INTERMEDIATE
MAINTENANCE MANUAL
INCLUDING REPAIR PARTS AND SPECIAL TOOLS LIST
FOR HYDRAULIC KNEELING/ERECTING CART,
PART NUMBER 10064-10**

REPORTING ERRORS AND RECOMMENDING IMPROVEMENTS

You can help improve this manual. If you find any mistakes or if you know of a way to improve the procedures, please let us know. Mail your letter, DA Form 2028 (Recommended Changes to Publications and Blank Forms), or DA Form 2028-2 located in the back of this manual direct to: Commander, US Army Aviation Systems Command, ATTN: AMSAVMC, 4300 Goodfellow Blvd., St. Louis, MO 63120-1798. A reply will be furnished to you.

	Title	Page
CHAPTER 1	INTRODUCTION	1-1
SECTION I	General Information.....	1-1
SECTION II	Equipment Description and Data	1-1
SECTION III	Technical Principles of Operation	1-8
CHAPTER 2	OPERATING INSTRUCTIONS	2-1
SECTION I	Description and Use of Operator's Controls and Indicators	2-1
SECTION II	Preventive Maintenance Checks and Services (PMCS).....	2-4
SECTION III	Operating Procedures (General).....	2-5
SECTION IV	Operating Procedures (AH-64)	2-6
CHAPTER 3	AVIATION UNIT AND INTERMEDIATE MAINTENANCE INSTRUCTIONS (AVUM, AVIM)	3-1
SECTION I	Repair Parts, Tools, and Test Equipment	3-1
SECTION II	Service Upon Receipt	3-1
SECTION III	Preventive Maintenance Checks and Services (PMCS).....	3-2
SECTION IV	Troubleshooting.....	3-5
SECTION V	Maintenance Procedures	3-9
SECTION VI	Preparation for Storage or Shipment	3-58

LIST OF APPENDICES

	Title	Page
APPENDIX A	REFERENCES	A-1
APPENDIX B	MAINTENANCE ALLOCATION CHART	B-1
SECTION I	Introduction	B-1
SECTION II	Maintenance Allocation Chart for Hydraulic Kneeling/Erecting Cart.....	B-3
SECTION III	Tool and Test Equipment Requirements.....	B-6
SECTION IV	Remarks	B-7

LIST OF APPENDICES (Continued)

	Title	Page
APPENDIX C	REPAIR PARTS AND SPECIAL TOOLS LIST	C-1
SECTION I	Introduction	C-1
SECTION II	Repair Parts and Special Tools List	
	Functional Group Numbers	
	00 - Hydraulic Kneeling/Erecting Cart	
	01 - Wheel	
	02 - Frame/Cabinet Assembly	
	03 - Hydraulic System	
	04 - Electrical System	
SECTION III	Special Tools List	C-10
SECTION IV	Cross Reference Index	I-1
A.	National Stock Number Index	I-1
B.	Part Number Index	I-2
C.	Figure and Item Number Index	I-7
APPENDIX D	EXPENDABLE SUPPLIES AND MATERIALS LIST	D-1
SECTION I	Introduction	D-1
SECTION II	Expendable Supplies and Materials List	D-1
ALPHABETICAL INDEX		Index 1

LIST OF ILLUSTRATIONS

Figure No.	Title	Page
1-1	Hydraulic Kneeling/Erecting Cart	1-0
1-2	Hydraulic Kneeling/Erecting Cart Major Internal Components	1-3
1-3	Hydraulic Schematic.....	1-5
1-4	Electrical Schematic.....	1-6
1-5	Electrical Wiring Diagram.....	1-7
2-1	Controls and Indicators	2-2
2-2	Main Landing Gear Kneeling Set-Up.....	2-11
1	Hydraulic Kneeling/Erecting Cart	
2	Frame/Cabinet Assembly	
3	Manifold Assembly	
4	Motor and Pump Assembly	
5	Reservoir Assembly	
6	Hydraulic Piping Assembly	
7	Control Box Assembly	
8	Electrical Components and Wiring Assembly	

LIST OF TABLES

Table No.	Title	Page
1-1	Equipment Data	1-8
2-1	Controls and Indicators.....	2-1
2-2	PMCS Checks.....	2-4
3-1	Inspection Requirements.....	3-3
3-2	Troubleshooting Procedure	3-5

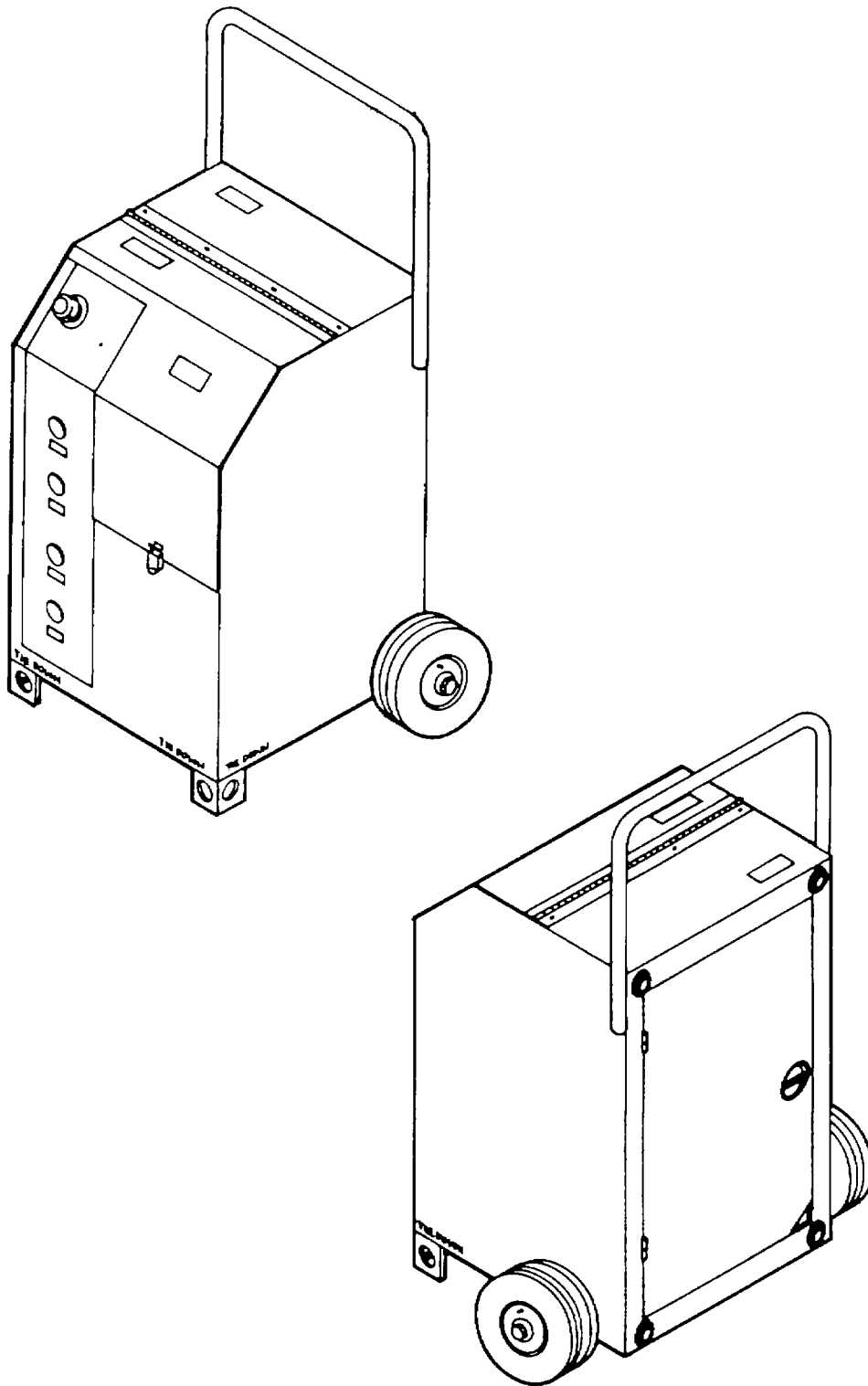

Figure 1-1. Hydraulic Kneeling/Erecting Cart

CHAPTER 1

INTRODUCTION

SECTION I. GENERAL INFORMATION

1-1. Scope.

Type of Manual: Operator's, Aviation Unit Maintenance and Intermediate Maintenance including Repair Parts and special Tools List.

Part Number and Equipment Name: Part Number: 10064-10; Hydraulic Kneeling/Erecting Cart.

Purpose of Equipment: Will hydraulically kneel and raise helicopter for loading into cargo aircraft by removing and replacing hydraulic fluid in helicopter landing gear struts.

1-2. Maintenance Forms, Records, and Reports. Department of the Army forms and procedures used for equipment maintenance will be those prescribed by DA PAM 738-751, the Functional Users Manual for The Army Maintenance Management System-Aviation (TAMMS-A).

1-3. Destruction of Army Materiel to Prevent Enemy Use. Procedures for destroying Army materiel to prevent enemy use are listed in TM 750-244-1-4 (FSC 1730).

1-4. Preparation for Storage or Shipment. These instructions are provided in Chapter 3, Section VI.

1-5. Reporting Equipment Improvement Recommendations (EIR). If your Hydraulic Kneeling/Erecting Cart needs improvement, let us know. Send us an EIR. You, the user, are the only one who can tell us what you don't like about your equipment. Let us know why you don't like the design. Put it on an SF 368 (Quality Deficiency Report). Mail it to us at: Commander, U.S. Army Aviation Systems Command, ATTN: AMSAV-QF, 4300 Goodfellow Blvd., St. Louis, MO 63120-1798. We'll send you a reply.

1-6. Calibration. There is no equipment which requires calibration regularly.

SECTION II. EQUIPMENT DESCRIPTION AND DATA

1-7. Characteristics and Purpose. The hydraulic kneeling/erecting cart (Figure 1-1) is portable and maneuverable by one person. It uses electric power supplied by aircraft or batteries to drive the hydraulic pump which kneels or erects the struts of a helicopter by removing and replacing hydraulic fluid.

NOTE

Relative position locations (front, rear, left, and right) are as viewed standing and facing the manifold assembly.

1-8. Capabilities and Features. The cart delivers MIL-H-5606 or MIL- H-83282 hydraulic fluid at a minimum rate of 1.2 gallons per minute (gpm) at 1,000 pounds per square inch (psi), and 0.4 gpm at 3,000 psi. The cart is mounted on two wheels with semi-pneumatic tires for easy travel on the flight line. Operator's controls and indicators are located at the front side of the cart under the control panel cover and on the controller stowed inside the cabinet. To familiarize using personnel with the cart characteristics and physical makeup, a table of equipment data is presented in Table 1-1 and some of the major components are identified in Figure 1-2.

1-9. Location and Description of Major Components. The major components (Figure 1-2) of hydraulic kneeling/erecting cart are: frame/cabinet assembly, manifold assembly, motor and pump assembly, reservoir assembly, hydraulic piping assembly, and the electrical wiring/components assembly.

a. Frame/Cabinet Assembly. The cart operating components, including the controls and indicators, are enclosed in a welded steel cabinet, (Figure 1-2). The cabinet is supported on semi-pneumatic tires at the rear corners and legs at the front corners. The legs have holes to facilitate in tiring down the cart for storage or during shipment. A handle is attached to the cabinet for ease in controlling, while moving the cart. A hinged removable door at the rear of the cabinet and a hinged control panel cover on top allow access to all internal components. The cabinet has an access to allow the power cable and controller to remain out with the door in the closed position during operation. A drain hole is located at the bottom of the cabinet. Three horizontally divided areas are available for storage of electrical cables and hydraulic hoses.

b. Manifold Assembly. The manifold assembly (Figures 1-2 and 1-3) houses the majority of controls and indicators used on the cart. Six solenoid valves (for tall, left, and right) permit/receive fluid flow to/from helicopter struts while a seventh solenoid valve allows fluid flow to recirculate to the oil reservoir when neither kneeling/erecting operations are being performed. Three manual flow regulators (for tall, left, and right) control the amount of flow to/from helicopter struts. Three quick disconnect couplings and dust caps (for tall, left, and right) are connected to the manifold at the front end. A pressure gage to read pump pressure developed is connected to the manifold. A variable pressure relief valve to adjust flow pressures between 100 and 3,000 psi is also attached to the manifold. The manifold assembly is easily accessible by lifting up the control panel cover.

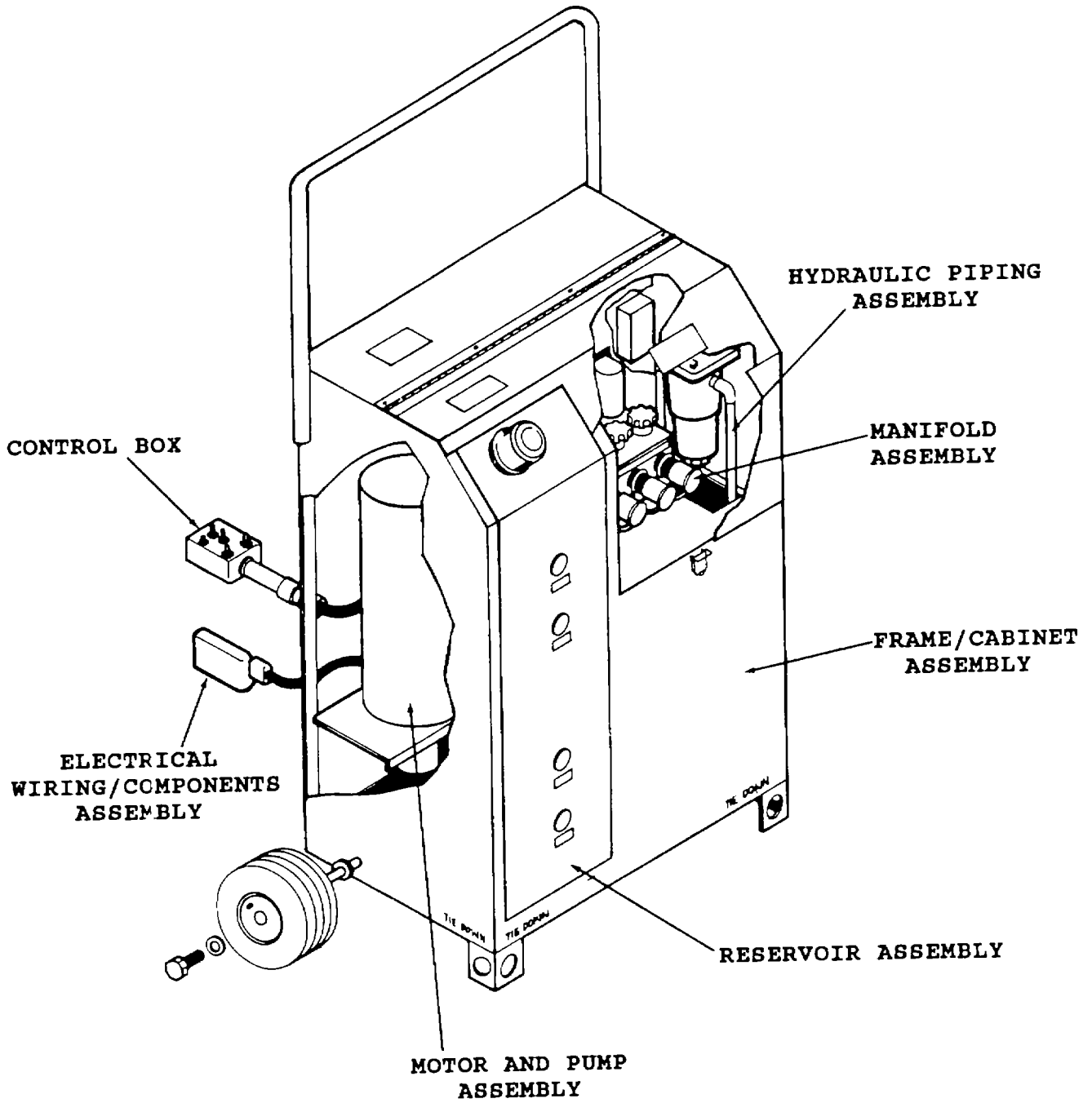

Figure 1-2. Hydraulic Kneeling/Erecting Cart Major Internal Components

c. Motor and Pump Assembly. The motor (Figures 1-2 and 1-4) receives 24 volt direct current (vdc) supply from either the aircraft, _F auxiliary power unit or batteries. The motor is a 1.5 horse power (hp), 1,800 revolutions per minute (rpm), totally enclosed non ventilated motor and drives the hydraulic gear pump through the flexible coupling which connects the motor output to pump input shafts. The pump rotation is clockwise and it pumps out minimum of 1.2 (gpm) at 1,000 psi and 0.4 gpm at 3,000 psi. The motor/pump adapter attaches the pump to the motor. A case covers the motor, start relay, circuit breaker, and electromagnetic interference filter to protect them from environment.

d. Reservoir Assembly. The reservoir assembly consists of a reservoir tank which can store 5 gallons of hydraulic fluid (MIL-H-5606 or MIL-H-83282) and supplies it for cart functions. A reservoir plate cover on top allows for reservoir clean out and incorporates the breather/filler with removable cap and the bleed adapter stored in the filler cavity. Four fluid level sight glasses are installed on the reservoir front side. The level at lowest level sight glass indicates the least amount of fluid required to operate the pump. The level at next higher sight glass indicates the normal operating level. The level at third higher sight glass indicates that the reservoir is full. The fluid level at uppermost sight glass indicates that the reservoir is about to overflow if more fluid is taken in. A drain plug is installed at the bottom of the reservoir. A suction strainer is installed inside the reservoir and a connection from the rear of the reservoir leads to the gear pump.

e. Hydraulic Piping Assembly. The hydraulic piping assembly consists of tubes, tees, elbows, and connectors connecting between reservoir, gear pump, filter, and the manifold (Figure 1-3). The filter is located in the outlet line from the gear pump and is easily accessible by lifting up the control panel cover. A 1 micron disposable filter element within the filter gives the pressurized fluid a final cleaning before outlet to the helicopter struts. A clogging indicator on the top of the filter indicates high differential pressure between the filter inlet and outlet. Should the filter element become clogged, a red marker will extend to show element requires replacement.

f. Electrical Wiring/Components Assembly. A 30 feet (ft)(762 mm) 24 vdc shielded power cable with power receptacle to mate with aircraft power plug is attached to the cart and stowed in the storage area. Another short cable with power plug at one end and battery clips/ connections at the other end is also stowed in storage area.

Another 50 ft (1270 mm) cable with non ferrous metallic controller is stowed in the storage area. The controller has four toggle switches and a POWER ON indicating light. One toggle switch is a maintained contact switch used for pump ON/OFF operations. The other three toggle switches are momentary contact and are used for tall, left, and right RAISE/LOWER operations to erect/kneel the helicopter struts. These toggle switches are fail-safe controls to prevent a fully loaded helicopter from lowering (kneeling) without the proper switches being

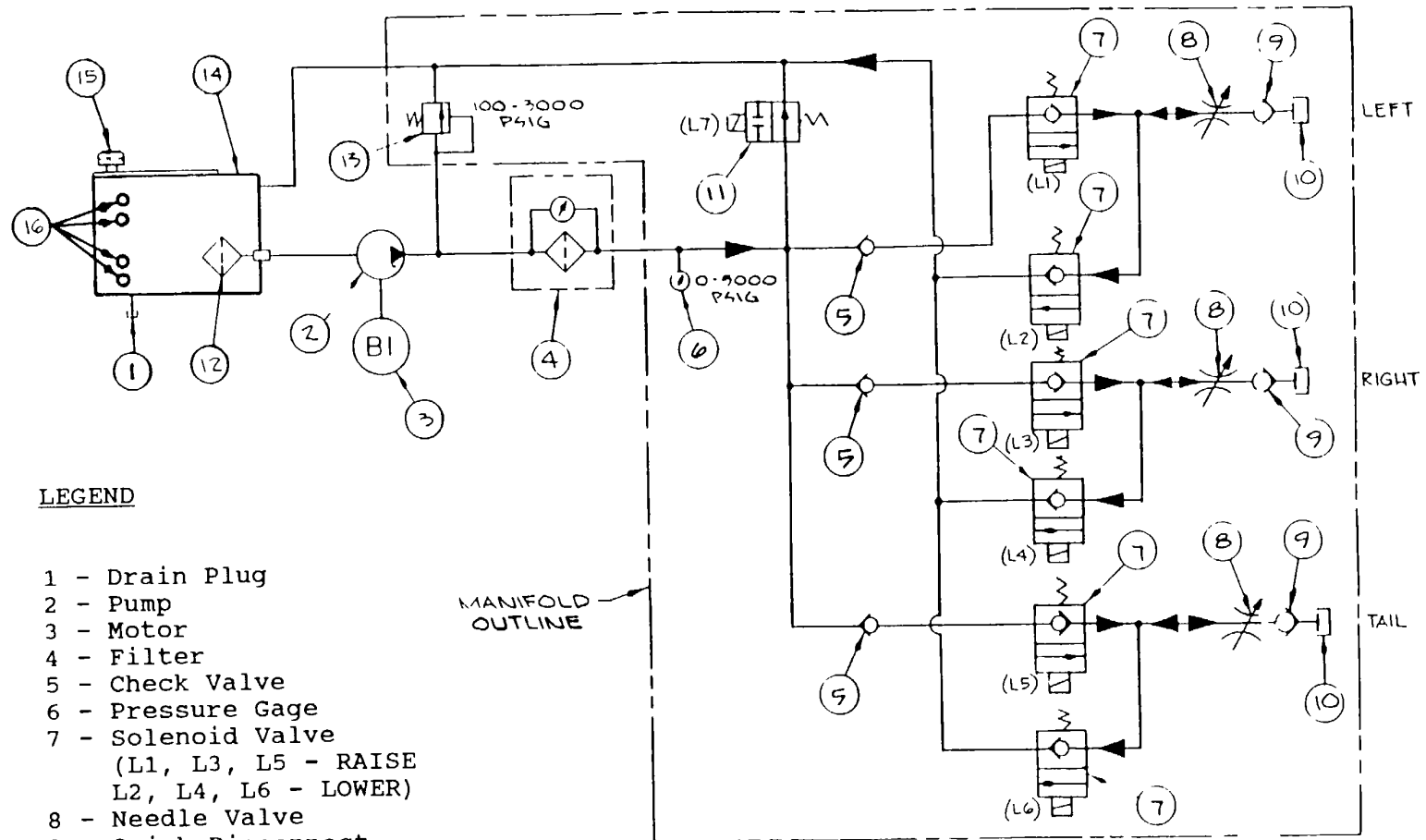
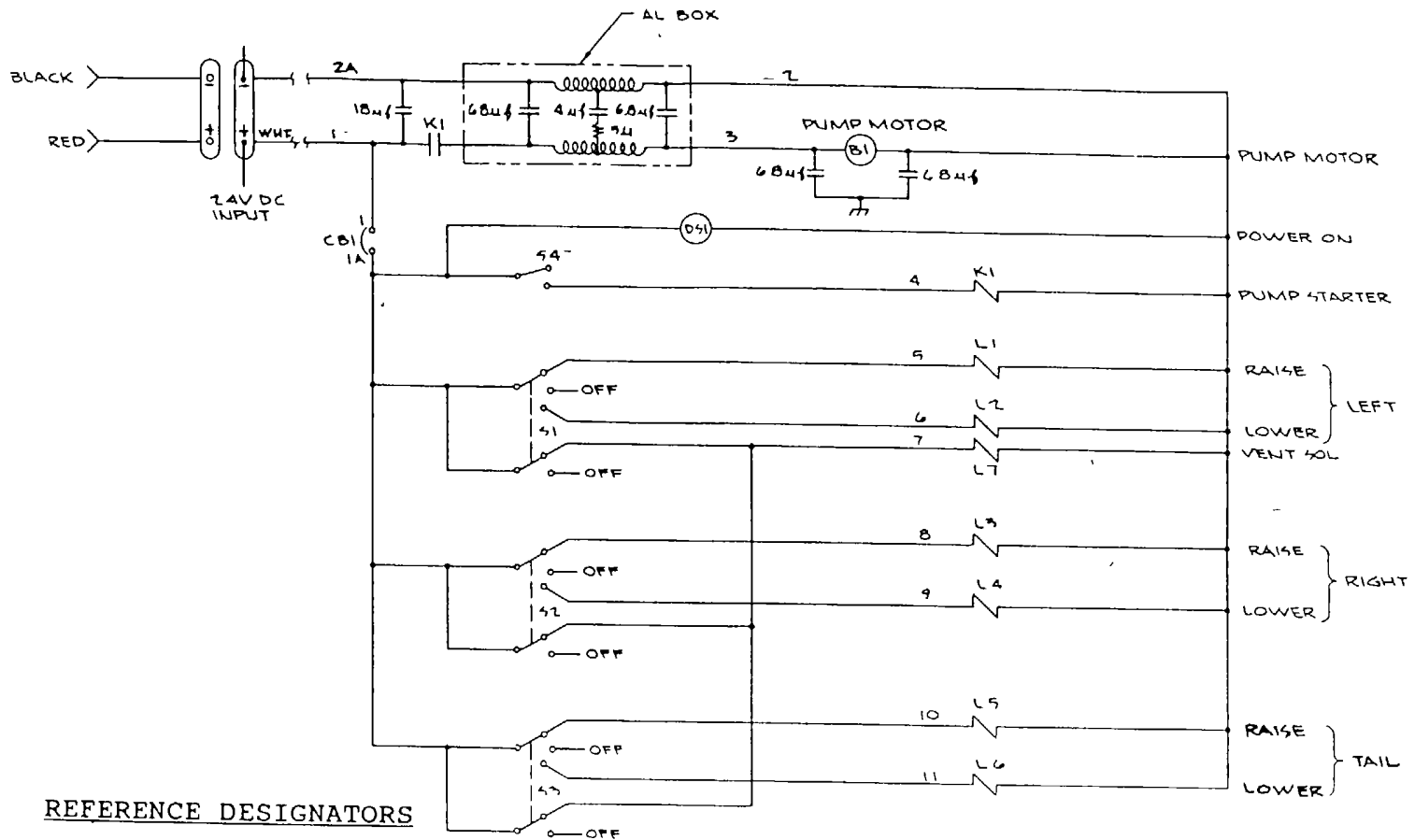

Figure 1-3. Hydraulic Schematic
1-5



REFERENCE DESIGNATORS

- B1 - Motor
- CB1 - Circuit Breaker
- DS1 - Indicator Light
- K1 - Start Relay
- L1-L7 - Solenoid Valves
- S1 - Control Switch (Left)
- S2 - Control Switch (Right)
- S3 - Control Switch (Tail)
- S4 - Control Switch (Pump)

Figure 1-4. Electrical Schematic

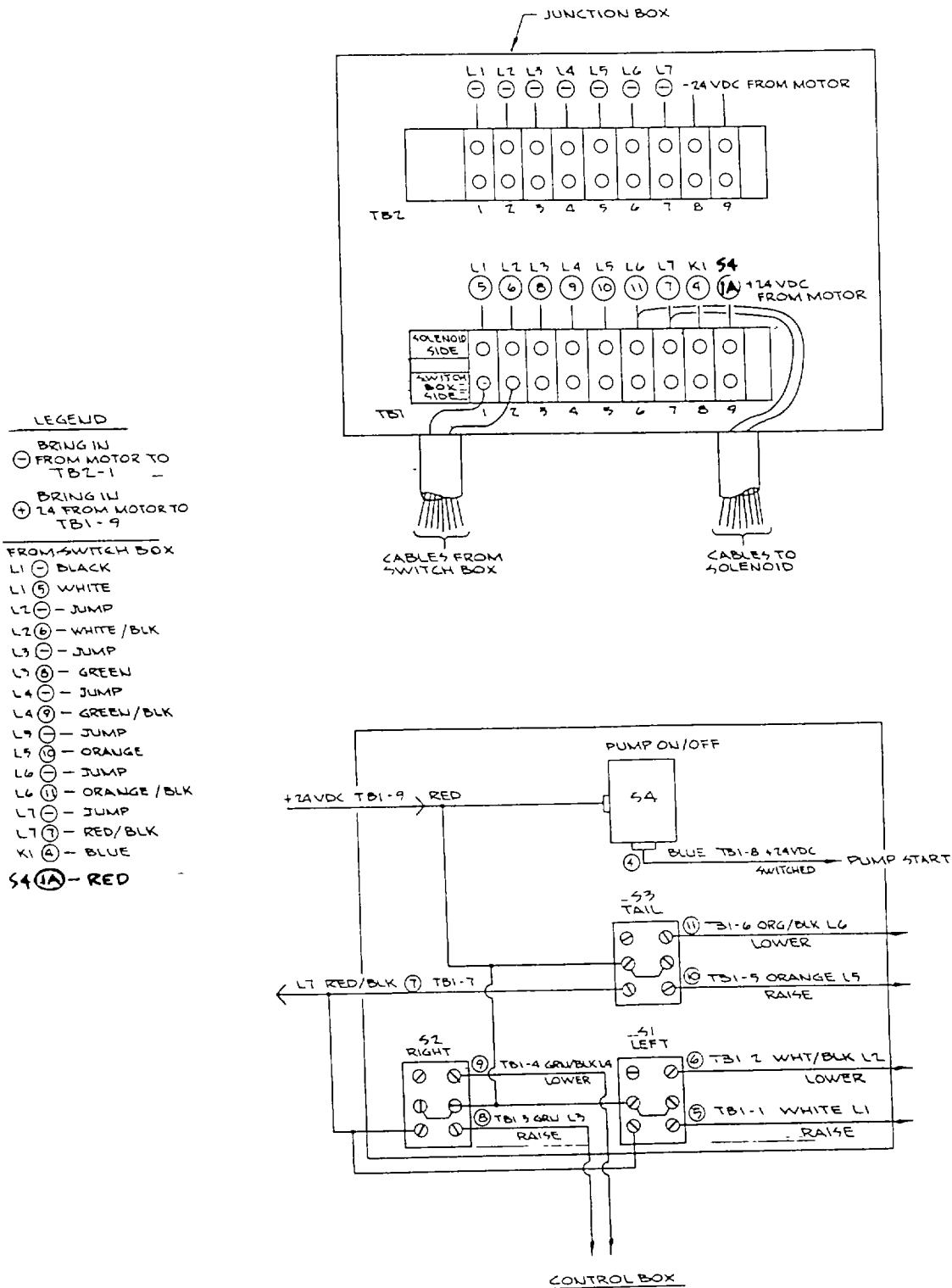

Figure 1-5. Electrical Wiring Diagram

activated. A thermal circuit breaker is installed in the motor case to safeguard the control circuit. An electromagnetic interference filter is also installed in the motor case. A grounding cable with one end to fit the aircraft receptacle is also stored on the shelf.

Table 1-1. Equipment Data

CHARACTERISTICS	PARTICULARS
Width Depth Height Weight Housing Mobility Ambient Temperature Storage Temperature Fluid Temperature Output Capability Reservoir Capacity Hydraulic Fluid Voltage	32 inches (in) (812.8 millimeters (mm)) (overall) 24 in (609.6 mm) 45 in (1143.0 mm) (including handle) 225 pounds (102.04 kilograms) (dry, excluding hoses) Metal, weather resistant Two semi-pneumatic tires for moving the cart. Tiedown holes provided in legs at front corners. -25 Deg. F (-32 Deg. C) to 125 Deg. F (52 Deg. C) -65 Deg. F (-54 Deg. C) to 160 Deg. F (71 Deg. C) 200 Deg. F (93 Deg. C) (maximum) 1.2 gpm at 1,000 psi (minimum) 0.4 gpm at 3,000 psi (minimum) 5 gallons (18.925 liters) MIL-H-5606 or MIL-H-83282 +24 vdc supplied by aircraft auxiliary power unit or batteries.

SECTION III. TECHNICAL PRINCIPLES OF OPERATION

1-10. Functional Description. Activating the pump toggle switch S4 (Figure 1-4) to ON position energizes the start relay K1 and closes its contacts allowing the 24 vdc supply to energize the pump motor B1 (3, Figure 1-3). The motor drives the gear pump (2) which takes hydraulic fluid from oil reservoir tank (14) and pumps to the filter (4). The 1 micron filtered fluid flows through the check valves (5) to the three solenoid valves (7) (L1, L3, and L5). Under normal conditions the solenoid valves (7) are closed while solenoid valve (11) should be in open position. This allows the fluid to recirculate through solenoid valve (11) back to the oil reservoir tank (14) to prevent overheating of fluid. To remove air from hydraulic hoses, connect one end of hose to the cart disconnect (9) and the other to the bleed adapter. Insert the bleed adapter into the filler/breather and observe the fluid flow after activating and holding the respective switch (S1, S2, or S3) in RAISE direction for duration of flow. Fluid flow should be continuous and without air bubbles. When that is

achieved, stop pump by moving S4 to OFF position. Hose is now free of air and ready to be connected to the helicopter strut. Remove air from the two other hoses also. Regulate the flow with manual flow needle valves (8) for the respective tall, left, or right operation. Activating and holding the toggle switch RAISE/LOWER in the RAISE position for tall, left, or right operations, sets the respective solenoid valve (7) (L1, L3, or L5) open to allow pumped fluid to the helicopter strut and it also energizes solenoid valve (11), shutting off the fluid flow to the oil reservoir tank (14). The toggle switch, when released always sets in the neutral position. Activating and holding the toggle switch RAISE/LOWER in the LOWER position for tall, left, or right operations sets the respective solenoid valve (7) (L2, L4, or L6) to allow fluid from helicopter strut to flow to the oil reservoir tank (14). The check valves (5) do not allow any fluid to flow through them from solenoid valve (7) (L1, L3, or L5).

CHAPTER 2

OPERATING INSTRUCTIONS

SECTION I. DESCRIPTION AND USE OF OPERATOR'S CONTROLS AND INDICATORS

2-1. Controls and Indicators. Controls and indicators for operation and monitoring of the hydraulic kneeling/erecting cart are located on the front side of the cart and on the controller which is stowed inside the cabinet. All controls and indicators are identified in Table 2-1 and located on Figure 2-1.

Table 2-1. Controls and Indicators

ITEM NO.	NOMENCLATURE	FUNCTION OR USE
1	Sight Glass, REMOVE FLUID	Hydraulic fluid level till this sight glass indicates that the reservoir is full about 5-1/2 gallons and fluid should be removed before further operation.
2	Sight Glass, FULL LEVEL	Hydraulic fluid in this sight glass indicates that the reservoir is full and holds about 4 gallons fluid.
3	Bleed Adapter	Used during removal of air from hydraulic hoses.
4	Filter Indicator	When extended red marker visible, indicates clogged filter.
5	Tall Manual Flow Regulator (Needle Valve)	Controls flow of fluid to/from helicopter tall strut.
6	Left Manual Flow Regulator (Needle Valve)	Controls flow of fluid to/from helicopter left strut.
7	Right Manual Flow Regulator (Needle Valve)	Controls flow of fluid to/from helicopter right strut.
8	Fluid Pressure Gage	Indicates gear pump output fluid pressure.

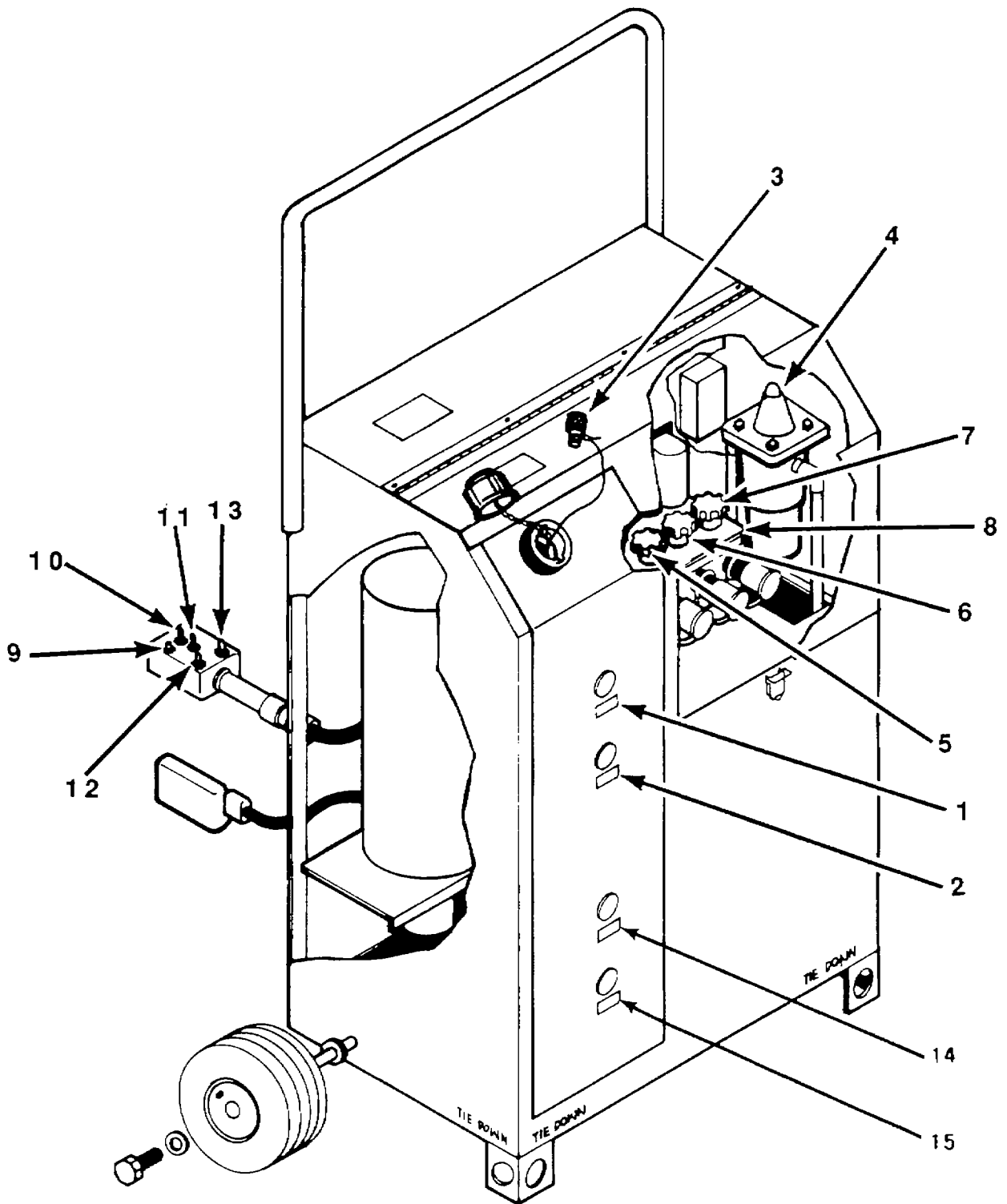

Figure 2-1. Controls and Indicators

Table 2-1. Controls and Indicators (Continued)

ITEM NO.	NOMENCLATURE	FUNCTION OR USE
9	POWER ON Indicating Light	When lit, it indicates power available to the controller.
10	Pump ON/OFF Control Switch (S4)	Moving switch to ON position starts the gear pump; moving switch to OFF position shuts-off the gear pump.
11	Tall RAISE/LOWER Switch (S3)	Moving and holding switch in RAISE position allows the helicopter tall strut to erect; moving switch and holding in LOWER position allows the helicopter tall strut to kneel (lower). Releasing the switch, sets to spring controlled neutral position.
12	Left RAISE/LOWER Switch (S1)	Moving and holding switch in RAISE position allows the helicopter left strut to erect; moving switch and holding in LOWER position allows the helicopter left strut to kneel (lower). Releasing the switch, sets to spring controlled neutral position.
13	Right RAISE/LOWER Switch (S2)	Moving and holding switch in RAISE position allows the helicopter right strut to erect; moving switch and holding in LOWER position allows the helicopter right the switch, sets to spring controlled neutral position.
14	Sight Glass, OPNL LEVEL	Hydraulic fluid in this sight glass indicates the normal operational level of fluid required to operate the unit and is about 2 gallons.
15	Sight Glass, LOW LEVEL	Hydraulic fluid in this sight glass Indicates low level of about 1 gallon and the unit must not be operated if fluid level is below the sight glass.

SECTION II. PREVENTIVE MAINTENANCE CHECKS AND SERVICES (PMCS)

2-2. PMCS Procedures. Perform these PMCS procedures prior to the hydraulic kneeling/erecting cart leaving its containment area. Table 2-2 lists the Inspections and care of the cart required to keep it in good operating condition. The table is divided in three columns:

a. *Item Column.* The item column lists the equipment being checked or serviced. Checks and services should be performed in the order specified.

b. *Interval Column.* The interval column Indicates when to do certain check or service.

c. *Procedures Column.* The procedures column indicates how to do the required checks and services.

Table 2-2. PMCS Checks

ITEM	INTERVAL	PROCEDURES
Hydraulic Reservoir	Preoperation	Check fluid level. Ensure that reservoir contains a minimum of 2 gallons of hydraulic fluid (till OPNL LEVEL) appropriate to the type of helicopter to be kneeled (See helicopter preparation for shipment manual). If the reservoir contains wrong type of hydraulic fluid or the type of fluid can not be determined, drain and flush cart hydraulic system prior to use (Paragraph 2-3). Inspect for leaks. Check hydraulic line connections for loose connections and damage. Correct defects prior to use.
Gage and Controls	Preoperation	Check for broken glass, bent indicating needle, or other obvious defects. Check that all controls operate smoothly and are tightly mounted. Correct or report defects.
Cabinet Interior	Preoperation	Check cable connections at power receptacle and plug and controller for breaks, worn insulation, and loose connections. Correct or report defects.

Table 2-2. PMCS Checks (Continued)

ITEM	INTERVAL	PROCEDURES
Tires	Preoperation	Inspect tires for deep cuts and excessive wear. Correct or report defects.

SECTION III. OPERATING PROCEDURES (GENERAL)

2-3. Drain and Flush Hydraulic Reservoir. When the cart contains hydraulic fluid different from that used on the helicopter or the type of fluid in the cart is not known, proceed as follows:

1. Drain reservoir by opening the reservoir tank drain plug at the bottom of the reservoir. Drain tank completely. Discard fluid properly.
2. Install drain plug.
3. Fill reservoir with 2 gallons (till OPNL LEVEL) of the appropriate hydraulic fluid (see helicopter preparation for shipment manual).
4. Remove grounding cable from cart and connect as required.
5. Remove controller from cabinet and ensure pump switch S4 (10, Figure 2-1) is in OFF position.
6. Connect power receptacle from cart to 24 vdc power supply.
7. Set pump switch S4 (10) to ON.
8. Operate pump for 3 minutes.
9. Set pump switch S4 (10) to OFF.
10. Disconnect power source and grounding cable.
11. Drain reservoir by opening reservoir tank drain plug at the bottom of the reservoir. Drain tank completely. Discard fluid properly.
12. Replace drain plug.
13. Service reservoir with 2 gallons of the specified hydraulic fluid.

2-4. Hydraulic Cart Operation. Personnel operating the cart must be familiar with the location and function of all controls and indicators. They must also have a thorough knowledge of the principles of operation involved.

WARNING

High hydraulic fluid pressures are developed during cart operation. The connecting hoses must be free of defects and the hose disconnects clean to avoid hose rupture or leaks.

2-5. Preliminary Checks. Prior to operation, the following steps should be taken to ensure the cart will operate properly and safely:

1. Open cabinet door and control panel cover prior to beginning checks.

WARNING

Use volatile solvents only in a well ventilated area. Avoid prolonged contact with skin.

2. Inspect the connecting hoses and clean hose disconnects using dry cleaning solvent, P-D-680, if necessary.

CAUTION

Never operate the cart if hydraulic fluid level in reservoir is less than LOW LEVEL sight glass. System damage could result. Replenish as required.

3. Observe reservoir sight glasses and add fluid, MIL-H-5606 or MIL-H-83282, until it is to the center of the OPNL LEVEL sight glass.
4. Inspect piping and fittings for obvious leaks.

SECTION IV. OPERATING PROCEDURES (AH-64)

2-6. Pre-operation Bleed Procedure. To remove air from the pipes and hoses, proceed as follows:

1. Ensure hydraulic cart is serviced with MIL-H-5606. If it is not, drain and flush hydraulic reservoir (Paragraph 2-3).
2. Connect two hoses from AH-64 hydraulic hose kit, P/N 7-262100019-601, to cart's hose quick disconnects (9, Figure 1-3). Connect one hose to left quick disconnect and one hose to right quick disconnect. (The tail quick disconnect is not used on the AH-64).
3. Remove grounding cable from cart and connect as required.

4. Remove controller from cabinet and ensure pump switch S4 (10, Figure 2-1) is in OFF position.
 5. Connect MS3506-1 power receptacle from cart to aircraft 24 vdc supply or to power plug on alternate 24 vdc source.
 6. Ensure POWER ON indicating light (9) is on.
 7. Open hydraulic fluid filler cap on reservoir. Remove bleed adapter (3) from it.
 8. Install bleed adapter (3) into the left hydraulic hose strut connector.
 9. Point and hold connector with bleed adapter (3) installed into the filler cavity.
 10. Ensure left manual flow regulator (6) is in open position (turn counterclockwise).
 11. Set pump switch S4 (10) to ON. Move left switch S1 (12) to RAISE and hold. Observe for fluid flow. When fluid flows without air bubbles, release S1. Set pump switch S4 to OFF. Remove bleed adapter (3) from hose.
 12. Install bleed adapter (3) into the right hydraulic hose strut connector.
 13. Point and hold connector with bleed adapter installed into the filler cavity.
 14. Ensure right manual flow regulator (7) is in open position (turn counterclockwise).
 15. Set pump switch S4 (10) to ON. Move right switch S2 (13) to RAISE and hold. Observe for fluid flow. When fluid flows without air bubbles, release S2. Set pump Switch S4 to OFF. Remove bleed adapter (3) from hose.
 16. After air is removed from hydraulic hose(s). Store bleed adapter in filler cap of reservoir and install hydraulic fluid filler cap.
 17. Replenish the hydraulic oil reservoir as necessary using MIL-H-5606.
 18. The system is now ready to connect to the helicopter.
- 2-7. Pre-operation Relief Valve Setting Check.** Prior to putting the cart into operation, relief valve setting should be observed and adjusted, if necessary. To perform, proceed as follows:
1. Remove grounding cable from cart and connect as required.

2. Remove controller from cabinet and set pump switch S4 (10, Figure 2-1) to OFF position.
3. Connect MS3506-1 power receptacle on cart to aircraft 24 vdc supply or to power plug for alternate 24 vdc source.
4. Ensure POWER ON indicating light (9) is on. Set pump switch S4 (10) to ON position.
5. Ensure manual flow regulators for tall, left, and right (5 through 7) are in fully closed position (turn clockwise).
6. Operate tall, left, or right switch (S3, S1, or S2) to RAISE direction and hold.
7. Observe pressure reading on pressure gage (8). It should not exceed 3,000 psig.
8. If reading is low or high, remove relief valve cap, loosen locknut, and turn adjusting screw with 3/16 in. (4.76 mm) allen key to set reading at 3,000 psig. Tighten locknut and install relief valve cap.

2-8. Kneeling and Erecting Operations for C-141B and Truck Shipment.

- a. Connect Shutoff Valve/Hoses to Landing Gear.

WARNING

To prevent injury and damage to equipment due to strut collapse and helicopter rollover, insure that hydraulic line is properly routed to prevent fouling. Route hydraulic line down through the access cover on top of the forward avionics bay (FAB) walkway to the landing gear kneeling nipple.

To prevent injury and damage to equipment due to strut collapse and helicopter rollover, do not force quick disconnect on to strut kneeling valve nipple. Difficulty in connecting quick disconnect may indicate strut collar is unlocked and if forced, the quick disconnect may fail. If difficulty is experienced, Dack helicopter (TM 55-1520-238-23) to relieve pressure before proceeding.

WARNING

To prevent injury and equipment damage from strut collapse and helicopter rollover, hydraulic lines must be properly connected. The cart operator stands in front of and facing the helicopter. Connecting the left hose to the right strut and the right hose to the left strut will avoid confusion during kneeling and erecting operations. The LEFT switch on the controller will operate the landing gear on the operators left. The RIGHT switch on the controller will operate the landing gear on the operators right.

1. Place hydraulic cart in front of helicopter with hydraulic cart and cart operator facing helicopter.
2. Open access cover on right hand FAB walkway and route aircraft end of left hand shutoff valve/hose down through opening.
3. Remove cap from kneeling nipple on right hand shock strut.
4. Connect aircraft end of left hand shutoff valve/hose quick disconnect to kneeling nipple on right hand landing gear strut.
5. Open access cover on left hand FAB walkway and route aircraft end of right hand shutoff valve/hose down through opening.
6. Remove cap from kneeling nipple on left hand shock strut.
7. Connect aircraft end of right hand shutoff valve/hose quick disconnect to kneeling nipple on left hand landing gear strut.

b. Kneel Helicopter.

WARNING

To prevent injury and equipment damage from strut collapse and helicopter rollover, personnel will be thoroughly familiar with procedures contained in this chapter prior to conduction kneeling or erecting operations.

WARNING

To prevent injury and equipment damage from strut collapse and helicopter rollover, personnel will remain clear of helicopter during kneeling or erecting operations.

To prevent injury from possible helicopter rollover, keep struts as close to the same length as possible during kneeling and erecting operations.

CAUTION

To prevent damage to equipment from excessive stress on helicopter landing gear and cargo aircraft winch, do not apply helicopter brakes during kneeling or erecting operations.

To prevent damage to equipment, maintain adequate overhead and underbelly clearance during kneeling and erecting operations.

(1). *Position personnel.*

1. Position one person to operate left shut off valve.
2. Position one person to operate right shut off valve.
3. Position one person to move hydraulic kneeling cart, as required.
4. Position one person to operate hydraulic cart.
5. Position personnel to monitor overhead and underbelly clearances.

(2). *Extend struts.*

NOTE

Landing gear struts are extended separately to ensure that hydraulic hoses are correctly connected.

1. Connect and check out cart (Paragraphs 2-4 and 2-5).

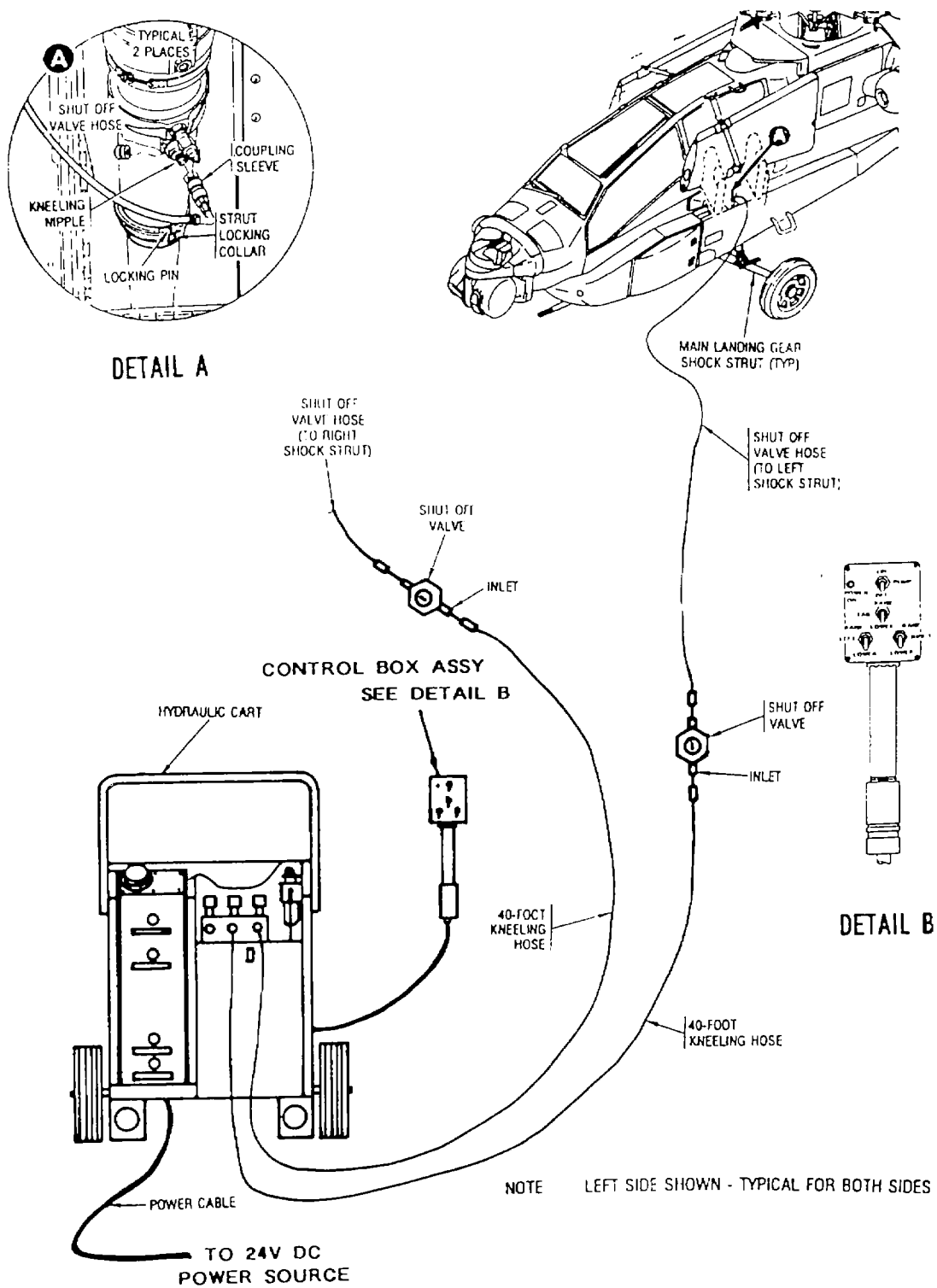

Figure 2-2. Main Landing Gear Kneeling Set-Up

2. Ensure that manual flow regulator for tail (5, Figure 2-1) is closed (turn clockwise) and manual flow regulators for left and right (6 and 7) are fully open (turn counterclockwise).
 3. Set pump switch S4 (10) to ON on controller.
 4. Move LEFT switch S1 (12) on controller to RAISE position. Ensure that landing gear on operators left is fully extended to its stop, release LEFT switch S1.
 5. Move RIGHT switch S2 (13) on controller to RAISE position. Ensure that landing gear on operators right is fully extended to its stop, release RIGHT switch S2.
- (3). *Inspect for hydraulic leaks.*

WARNING

To prevent injury and equipment damage from strut collapse and helicopter rollover, do not proceed until all leaks are repaired.

1. Inspect landing gear, hoses, fittings, valves and hydraulic cart for leaks.
 2. Repair leaks as required.
- (4). *Unlock strut collars.*

NOTE

If landing gear collars do not rotate clockwise easily, the landing gear strut has not been fully extended. Fully extend strut (step (2)) before proceeding.

1. Remove aircraft left strut collar locking pin, rotate collar clockwise to unlock, reinstall locking pin.
 2. Remove aircraft right strut collar locking pin, rotate collar clockwise to unlock, reinstall locking pin.
- (5). *Position helicopter at desired height.*
1. Slowly kneel helicopter by moving LEFT and RIGHT

switches S1 and S2 (12 and 13, Figure 2-1) on controller to LOWER position.

2. Slowly erect helicopter by moving LEFT and RIGHT switches S1 and S2 (12 and 13) on controller to RAISE position.
- (6). *Disconnect hydraulic cart (Kneeled condition).*

WARNING

To prevent injury and equipment damage from strut collapse and helicopter rollover, ensure that there is no strut movement after closing shutoff valves. Strut movement indicates a leaking shutoff valve that must be replaced prior to shipment.

CAUTION

To prevent damage to strut kneeling nipple, shutoff valve hoses must remain attached to the helicopter when it is in the kneeled position.

1. Close left and right shutoff hose valves.
2. Move LEFT and RIGHT switches S1 and S2 (12 and 13, Figure 2-1) on controller to LOWER position to bleed pressure from kneeling hoses.
3. Disconnect left and right 40 foot kneeling hoses from hydraulic cart and shutoff valves. Install dust caps on both 40 foot kneeling hoses.
4. Set pump switch S4 (10) to OFF on controller.
5. Disconnect electrical power supply and grounding cable from power source and helicopter.
6. Position cart for kneeling next helicopter or prepare for transport, as appropriate.

c. Erect Helicopter.**WARNING**

To prevent injury and equipment damage from strut collapse and helicopter rollover, personnel will be thoroughly familiar with procedures contained in this chapter prior to conduction kneeling or erecting operations.

To prevent injury and equipment damage from strut collapse and helicopter rollover, personnel will remain clear of helicopter during kneeling or erecting operations.

To prevent injury from possible helicopter rollover, keep struts as close to the same length as possible during kneeling and erecting operations.

CAUTION

To prevent damage to equipment from excessive stress on helicopter landing gear and cargo aircraft winch, do not apply helicopter brakes during kneeling or erecting operations.

To prevent damage to equipment, maintain adequate overhead and underbelly clearance during kneeling and erecting operations.

(1). *Connect hydraulic cart.*

1. Ensure there is hydraulic fluid till OPNL LEVEL sight glass (14, Figure 2-1) (approximately two gallons) in the hydraulic cart reservoir.
2. Connect hydraulic cart to electrical grounding cable and power source.

(2). *Start hydraulic cart.* Paragraphs 2-4 and 2-5.(3). *Bleed air from hydraulic hoses.* Paragraph 2-6. (As required)

- (4). *Connect 40 foot kneeling hoses to shutoff valve/hoses connected to helicopter.*

WARNING

To prevent injury and equipment damage from strut collapse and helicopter roll-over, hydraulic lines must be properly connected. The cart operator stands in front of and facing the helicopter. Connecting the left hose to the right strut and the right hose to the left strut will avoid confusion during kneeling and erecting operations. The LEFT switch on the controller will operate the landing gear on the operators left. The RIGHT switch on the controller will operate the landing gear on the operators right.

1. Place hydraulic cart in front of helicopter with hydraulic cart and cart operator facing helicopter.
 2. Connect left hand 40 foot kneeling hose to right hand landing gear strut shutoff valve/hose.
 3. Connect right hand 40 foot kneeling hose to left hand landing gear strut shutoff valve/hose.
- (5). *Position personnel.* Paragraph 2-8b(1).
- (6). *Raise helicopter.*

NOTE

Before fully erecting helicopter, switches are checked separately to ensure that hydraulic hoses are correctly connected.

1. Set pump switch S4 (10, Figure 2-1) to ON on controller.
2. Open left and right shutoff valves.
3. Momentarily move LEFT switch S1 (12) on controller to RAISE position. Ensure that landing gear on operators left extends, release LEFT switch S1.

4. Momentarily move RIGHT switch S2 (13) on controller to RAISE position. Ensure that landing gear on operators right extends, release RIGHT switch S2.
 5. Slowly erect helicopter by moving LEFT and RIGHT switches S1 and S2 (12 and 13) on controller to RAISE position until helicopter struts are fully extended.
- (7). *Lock landing gear collars.*
1. Remove aircraft left strut collar locking pin, rotate collar counterclockwise to lock, reinstall locking pin.
 2. Remove aircraft right strut collar locking pin, rotate collar counterclockwise to lock, reinstall locking pin.
 3. Move LEFT and RIGHT switches S1 and S2 (12 and 13, Figure 2-1) on controller to LOWER position to depressurize hydraulic hoses.
 4. Set pump switch S4 (10) to OFF on controller.
- (8). Disconnect hydraulic cart (Erected condition).
1. Close left and right shutoff hose valves.
 2. Disconnect left and right shutoff valve/hoses from helicopter. Install caps on both left and right kneeling nipples.
 3. Disconnect electrical power supply and grounding cable from power source and helicopter.
 4. Secure access covers on both left and right FAB walkways.
 5. Position cart for kneeling next helicopter or prepare for storage, as appropriate.

2-9. Kneeling and Erecting Operations for C-5 Shipment (Rear Door Load Only).

- a. *General.* This provides instructions for the operation of the hydraulic cart and for the kneeling and erecting of the AH-64A helicopter for transport C-5 cargo aircraft, rear door load only.
- b. *Applicability.* Personnel will be thoroughly familiar with and practiced in these procedures prior to performing kneeling and erecting operations in conjunction with helicopter transport operations.

- c. Configure Helicopter for Shipment. Prior to performing kneeling and erecting operations, configure the helicopter for kneeling.
- d. Connect and Check Out Hydraulic Cart (Outside of C-5 Cargo Aircraft). Section III.
- e. Kneel Helicopter (Outside of C-5 Cargo Aircraft). Paragraph 2-8b.
- f. Erect Helicopter (Inside C-5 Cargo Aircraft).

NOTE

The helicopter will be kneeled and erected, as required, for underbelly and overhead clearance while winching helicopter into C-5 cargo compartment. After the helicopter has been winched into cargo compartment, helicopter will be erected.

WARNING

To prevent injury and equipment damage from strut collapse and helicopter roll-over, personnel will be thoroughly familiar with procedures contained in this chapter prior to conduction kneeling or erecting operations.

To prevent injury and equipment damage from strut collapse and helicopter roll-over, personnel will remain clear of helicopter during kneeling or erecting operations.

To prevent injury from possible helicopter rollover, keep struts as close to the same length as possible during kneeling and erecting operations.

CAUTION

To prevent damage to equipment from excessive stress on helicopter landing gear and cargo aircraft winch, do not apply helicopter brakes during kneeling or erecting operations.

CAUTION

To prevent damage to equipment, maintain adequate overhead and underbelly clearance during kneeling and erecting operations.

Paragraph 2-8c.

- g. *Kneel Helicopter (Inside C-5 Cargo Aircraft).*

WARNING

To prevent injury and equipment damage from strut collapse and helicopter roll-over, personnel will be thoroughly familiar with procedures contained in this chapter prior to conduction kneeling or erecting operations.

To prevent injury and equipment damage from strut collapse and helicopter roll-over, personnel will remain clear of helicopter during kneeling or erecting operations.

To prevent injury from possible helicopter rollover, keep struts as close to the same length as possible during kneeling and erecting operations.

CAUTION

To prevent damage to equipment from excessive stress on helicopter landing gear and cargo aircraft winch, do not apply helicopter brakes during kneeling or erecting operations.

To prevent damage to equipment, maintain adequate overhead and underbelly clearance during kneeling and erecting operations.

- (1). *Start hydraulic cart.* Paragraphs 2-4 and 2-5.
- (2). *Bleed air from hydraulic hoses.* Paragraph 2-6. (As required.)
- (3). *Connect 40 foot kneeling hoses to shutoff valve/hoses connected to helicopter.* Paragraph 2-8c(4).

- (4). *Position personnel.* Paragraph 2-8b(1).
- (5). *Extend struts.* Paragraph 2-8b(2).
- (6). *Inspect for hydraulic leaks.* Paragraph 2-8b(3).
- (7). *Unlock strut collars.* Paragraph 2-8b(4).
- (8). *Position helicopter at desired height.* Paragraph 2-8b(5).

NOTE

The helicopter will be kneeled and erected, as required, for underbelly and overhead clearance while removing helicopter from C-5 cargo compartment. After the helicopter has been removed from cargo compartment, helicopter will be erected.

- h. *Erect Helicopter (Outside C-5 Cargo Aircraft).*

WARNING

To prevent injury and equipment damage from strut collapse and helicopter roll-over, personnel will be thoroughly familiar with procedures contained in this chapter prior to conduction kneeling or erecting operations.

To prevent injury and equipment damage from strut collapse and helicopter roll-over, personnel will remain clear of helicopter during kneeling or erecting operations.

To prevent injury from possible helicopter rollover, keep struts as close to the same length as possible during kneeling and erecting operations.

CAUTION

To prevent damage to equipment from excessive stress on helicopter landing gear and cargo aircraft winch, do not apply helicopter brakes during kneeling or erecting operations.

CAUTION

To prevent damage to equipment, maintain adequate overhead and underbelly clearance during kneeling and erecting operations.

Paragraph 2-8c.

CHAPTER 3

AVIATION UNIT AND INTERMEDIATE MAINTENANCE INSTRUCTIONS (AVUM, AVIM)

SECTION I. REPAIR PARTS, TOOLS, AND TEST EQUIPMENT

3-1. Common Tools and Equipment. For authorized common tools and equipment refer to the Modified Table of Organization and Equipment (MTOE) applicable to your unit.

3-2. Common Tools for AVUM and AVIM. See Appendix B, Section III.

3-3. Special Tools. No special tools are required.

3-4. Test Equipment. No test equipment is required.

3-5. Repair Parts. Repair parts are listed and illustrated in Appendix C of this manual.

SECTION II. SERVICE UPON RECEIPT

3-6. Unpacking and Installation. The kneeling/erecting cart is shipped completely assembled on semi-pneumatic tires and requires no assembly of components prior to preparing the cart for use. Remove cart from packing boxes and open cabinet door and control panel cover. Thoroughly inspect interior of the cart. Remove all extraneous packing or cushioning material used to protect internal components during shipment. Small areas of normally exposed metal surfaces may be wrapped with protective paper covering or tape during shipment. Be certain all such coverings are removed.

3-7. Initial Inspection. It is important to carefully inspect the complete cart for any possible damage which may have occurred during shipment. The following initial inspection procedures are recommended:

1. Check the data appearing on the cart nameplate to verify it is the type of unit designated in paragraph 1-1 of this manual. If there is any doubt, do not operate the cart.
2. Open the control panel cover. Inspect gage, filter indicator, and controls for evidence of shipping damage. Check that all parts are securely mounted.
3. Open cabinet door. Inspect the plumbing installation for damaged tube assemblies or fittings. Check that all fittings are securely connected.
4. Carefully inspect the electrical wiring for broken wires or

frayed insulation. Check that all electrical connections are secure. Check that all manually operated switches and controls on controller operate freely.

5. Inspect hydraulic oil reservoir for evidence of physical damage in shipment. Check that the sight glasses are not damaged. Check the fluid system carefully for evidence of leakage.
6. Inspect tires for cuts or abrasions and remove any imbedded objects from treads.
7. Inspect cabinet for any damage. Check door lock and panel cover latch for proper closing and locking.
8. Remove power and controller cables from the cart. Lay out cables and inspect condition of cable and end fittings. Any damage to the cable end fitting or evidence of broken wires in the cable is cause for replacement of the cable.

3-8. Servicing Hydraulic System. Service the hydraulic system for use as follows:

1. The hydraulic reservoir tank (14, Figure 1-3) has been coated with MIL-H-6083 preservative fluid for shipment. MIL-H-6083 is compatible with the operating fluids listed for use. Make certain drain plug is installed.

CAUTION

Hydraulic fluid MIL-H-5606 or MIL-H-83282 should only be used on struts. This fluid should not be used on other aircraft or helicopter systems.

2. Fill reservoir tank at filler neck with hydraulic fluid, MIL-H-5606 or MIL-H-83282, until fluid is to the center of the OPNL LEVEL sight glass (14, Figure 2-1).

SECTION III. PREVENTIVE MAINTENANCE CHECKS AND SERVICES (PMCB)

3-9. General Information. Maintenance consists of periodic inspections of the hydraulic and electrical components, including piping and connections; replacement of filter elements; testing of instrument accuracy; troubleshooting a malfunctioning unit; and lubrication. The cart shall be periodically inspected in accordance with Table 3-1. Lubrication shall be performed as part of periodic inspection and in accordance with paragraph 3-10. The inspection table is in columnar parts;

1. Item number column: it lists checks and services to be performed in chronological order regardless of interval.

2. Interval column: has checks (x) placed in the appropriate interval column in front of the procedure to be performed.
3. Item to be inspected/procedures column: lists the item to be inspected and procedure to do that.
4. Equipment is not ready/available column: lists the status for the check only if the cart is not ready for operation.

TABLE 3-1. Inspection Requirements

INTERVAL DEFINITIONS							
D - DAILY		Q - QUARTERLY		S - SEMI-ANNUALLY		A - ANNUALLY	
ITEM NO.	INTERVAL				ITEM TO BE INSPECTED/PROCEDURE: CHECK FOR AND HAVE REPAIRED, FILLED, OR ADJUSTED AS NEEDED	EQUIPMENT IS NOT READY/AVAILABLE IF:	
	D	Q	S	A			
1	x				CABINET/FRAME Access door and control panel cover hinges for free movement; lubricate if needed.		
2				x	Chipped paint and metal exposure; service in accordance with TM 43-0139.		
3				x	Identification plates and markings for legibility.		
4			x		MANIFOLD ASSEMBLY Loose mounting.		
5	x				Pressure gage for cracked or broken glass.	Gage is not reading correctly.	
6	x				Pressure gage calibration - check calibration date	Calibration date is expired.	
7	x				Manual flow regulators leakage at stem due to damaged O-ring.		
8	x				Damage to coils of solenoid valves.	Solenoid valves not operating correctly.	

Table 3-1. Inspection Requirements (Continued)

INTERVAL DEFINITIONS							
D - DAILY		Q - QUARTERLY		S - SEMI-ANNUALLY		A - ANNUALLY	
ITEM NO.	INTERVAL				ITEM TO BE INSPECTED/PROCEDURE: CHECK FOR AND HAVE REPAIRED, FILLED, OR ADJUSTED AS NEEDED	EQUIPMENT IS NOT READY/AVAILABLE IF:	
	D	Q	S	A			
9	x				Relief valve adjusted properly.	Not delivering correct pressure due to incorrect relief valve setting.	
MOTOR AND PUMP ASSEMBLY							
10				x	Inspect motor brushes for condition - if worn out, replace brushes.	DC motor brushes worn out.	
11				x	Pump not turning freely.	Pump is damaged.	
12			x		Flexible coupling rubber spider is damaged or worn out.	Flexible coupling is damaged.	
HYDRAULIC RESERVOIR TANK							
13	x				Check fluid level.	Fluid level is below OPNL LEVEL sight glass.	
14				x	Inspect internal reservoir tank by opening cover; clean strainer.	Contamination exists.	
15	x				Check filler/breather cap and screen for presence and condition.		
16	x				Check the four sight glasses for leaks or cracks.	Sight glass is broken.	
HYDRAULIC PIPING ASSEMBLY							
17	x				Hydraulic line connections for tightness/leaks.		

Table 3-1. Inspection Requirements (Continued)

		INTERVAL DEFINITIONS				
		D - DAILY	Q - QUARTERLY	S - SEMI-ANNUALLY	A - ANNUALLY	
ITEM NO.	INTERVAL				ITEM TO BE INSPECTED/PROCEDURE: CHECK FOR AND HAVE REPAIRED, FILLED, OR ADJUSTED AS NEEDED	EQUIPMENT IS NOT READY/AVAILABLE IF:
	D	Q	S	A		
18	x				TIRES/WHEELS AND FILTER Inspect tires for deep cuts, excessive wear, and embedded foreign matter.	Filter is clogged.
19	x				Inspect for loose wheel mounting bolts.	
20			x		Inspect wheel bearings for lubrication fittings and grease.	
21	x				Inspect filter indicator for dirty or clogged indication.	
22	x				ELECTRICAL CABLES/WIRES Check electrical cables and wires for breaks, worn insulation, and loose connections.	

3-10. Lubrication. Grease cart wheel bearings with MIL-G-10924 grease, using grease gun, and oil door and control panel cover hinges with VV-L-800 oil using oil can.

SECTION IV. TROUBLESHOOTING

3-11. Troubleshooting. In the event that operation of the cart becomes faulty or erratic, refer to the troubleshooting procedure, Table 3-2, to aid in isolating and correcting troubles.

Table 3-2. Troubleshooting Procedure

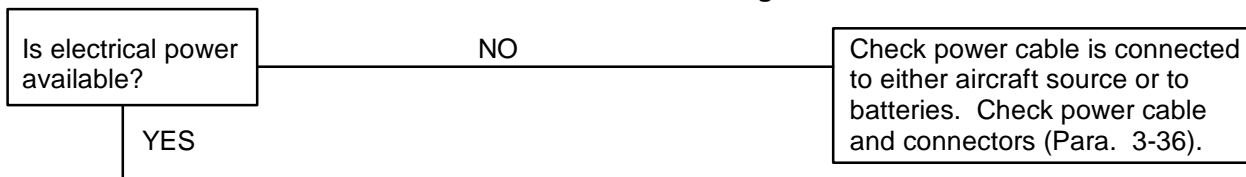

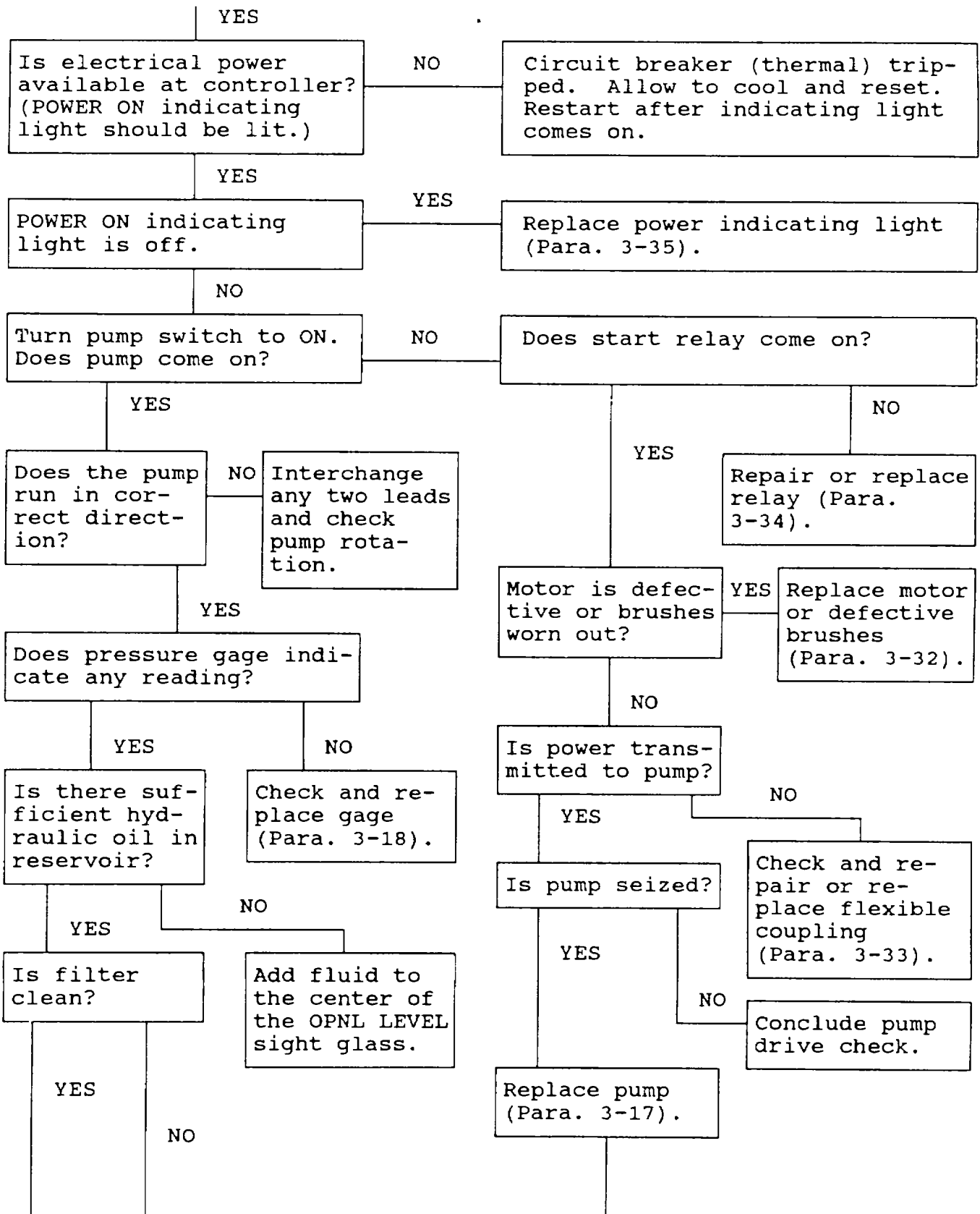

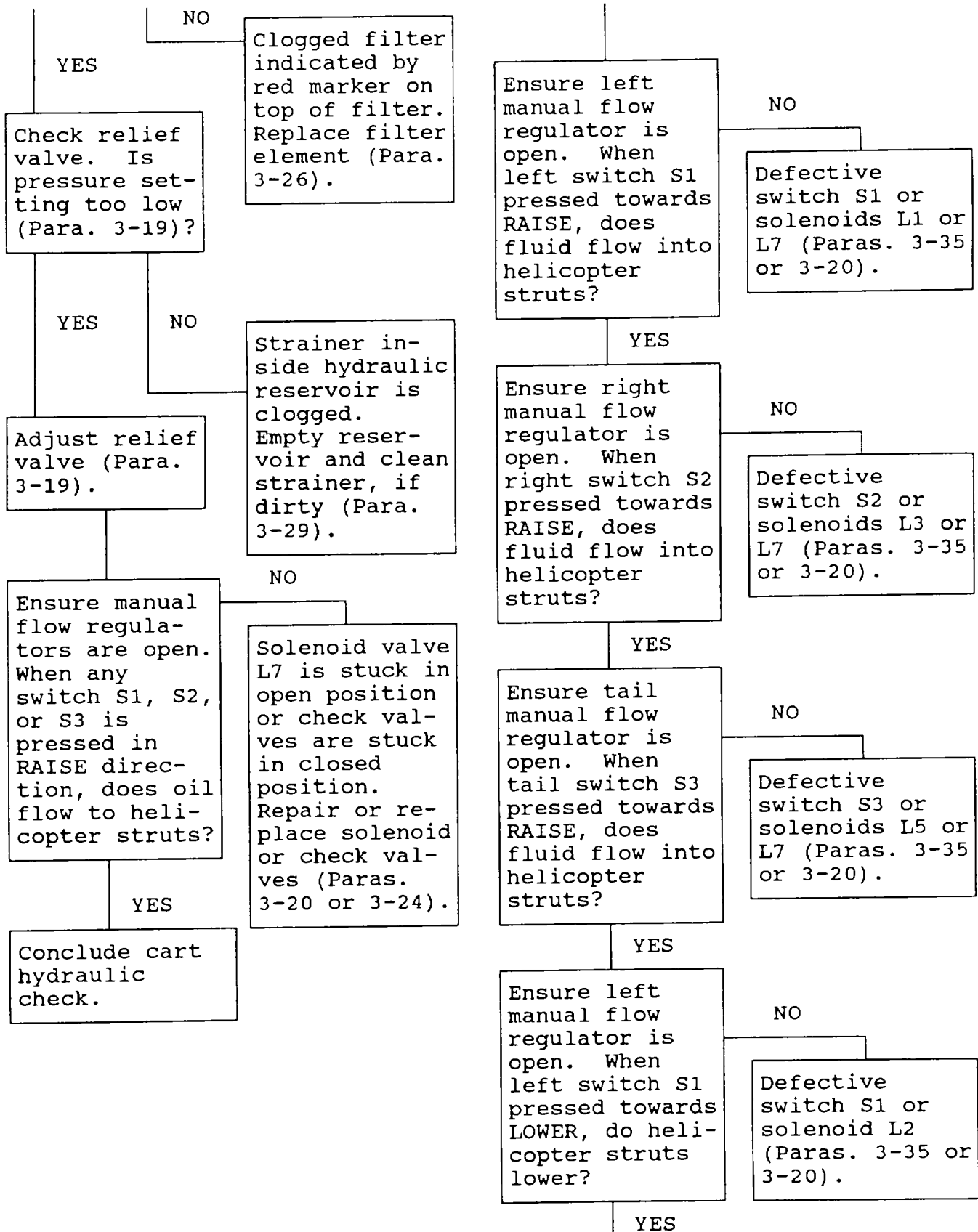

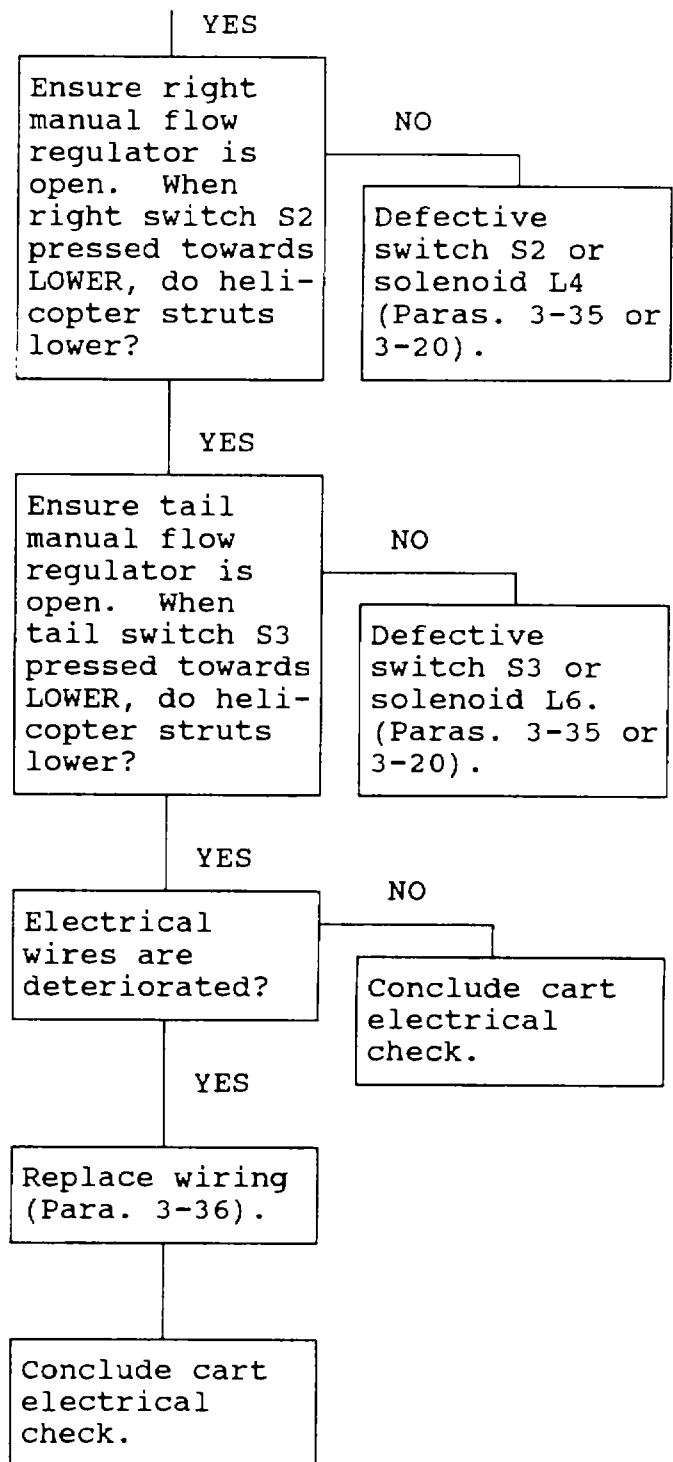

SECTION V. MAINTENANCE PROCEDURES

3-12. General Information. This section provides repair or replacement instructions authorized at the Aviation Unit Maintenance (AVUM) level. Repair or replacement of all other parts is to be done at the Aviation Intermediate Maintenance (AVIM) level (annotated in parenthesis after the component to be maintained). The AVUM/AVIM Maintenance procedures complies with the Maintenance allocation Chart (MAC), Appendix B.

3-13. WHEEL**3-13**

This task covers:	A. INSPECTION	B. SERVICE	C. REMOVAL
	D. INSTALLATION		

INITIAL SETUPTools

Tool Kit, Aircraft Mechanics General, NSN 5180-00-323-4692

Grease Gun

Block, Wooden

Materials

Grease, MIL-G-10924

Personnel Required

MOS 67

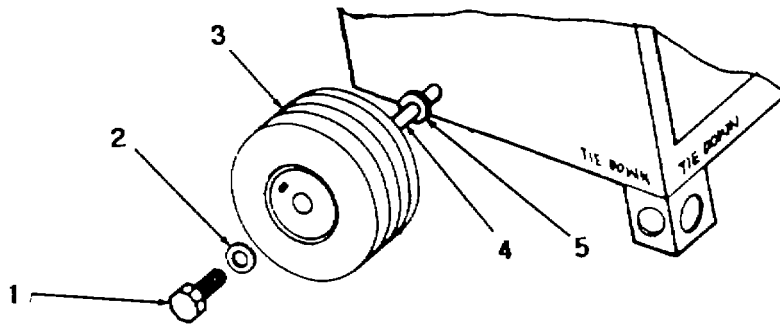
**A. INSPECTION**

1. Check tires for cuts, defects, and wear.
2. Check tires for any object imbedded in the treads.

B. SERVICE

Using grease gun, apply grease to fitting on wheel.

C. REMOVAL

1. Set cart on wooden block to ease removal of wheel.
2. Remove screw (1) and flat washer (2) from wheel (3).
3. Remove wheel from axle bar (4). Remove spacer (5) from axle bar (4).

D. INSTALLATION

1. Install spacer (5) on axle bar (4) till as far as it will go.
2. Install wheel (3) on axle bar (4).
3. Secure wheel with flat washer (2) and screw (1).

END OF TASK

3-14. CONTROL PANEL COVER AND LATCH ASSEMBLY

3-14

This task covers: A. INSPECTION B. REPAIR (AVIM) C. REMOVAL
 D. INSTALLATION

INITIAL SETUP

Tools

Tool Kit, Aircraft Mechanics General, NSN 5180-00-323-4692
 Shop Set, AVIM, Sheet Metal, NSN 4920-00-166-5505
 Shop Set, AVIM, Welding, NSN 4920-00-163-5093

Personnel Required

MOS 67 and MOS 68G

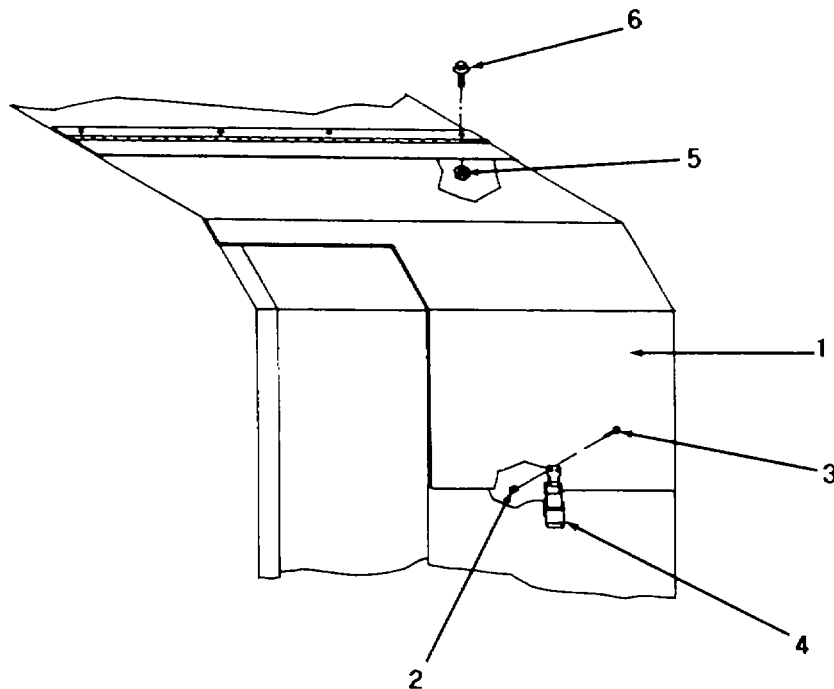

A. INSPECTION

Inspect control panel cover (1) for damage or wear and latching in closed position.

B. REPAIR (AVIM)

1. Remove dents where possible and repair welds as necessary.
2. Replace latching hardware, and hinges if worn or damaged.

GO TO NEXT PAGE

3-14. CONTROL PANEL COVER AND LATCH ASSEMBLY - Continued

3-14**C. REMOVAL**

Remove two locknuts (2) and screws (3) and remove latch assembly (4). Remove four nuts (5) and bolts (6) and remove control panel cover (1).

D. INSTALLATION

Place control panel cover (1) in position and secure with four bolts (6) and nuts (5). Place latch assembly (4) in position and secure with two screws (3) and locknuts (2).

END OF TASK

3-15. CABINET DOOR

3-15

This task covers: A. INSPECTION B. REPAIR (AVIM) C. REMOVAL
 D. INSTALLATION

INITIAL SETUPTools

Tool Kit, Aircraft Mechanics General, NSN 5180-00-323-4692
Shop Set, AVIM, Sheet Metal, NSN 4920-00-166-5505
Shop Set, AVIM, Welding, NSN 4920-00-163-5093

Personnel Required

MOS 67 and MOS 68G

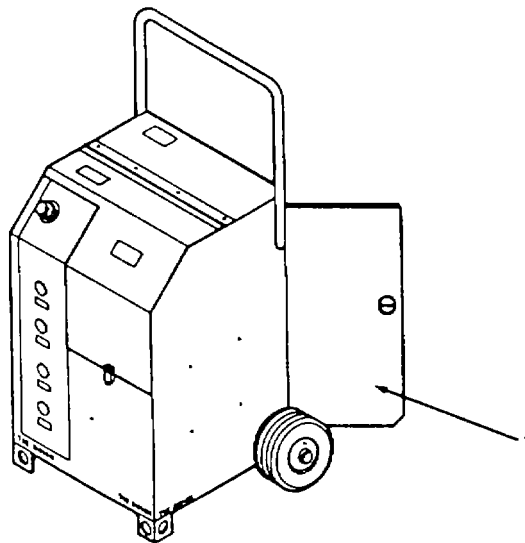
**A. INSPECTION**

Inspect cabinet door (1) for damage or wear and closing.

B. REPAIR (AVIM)

1. Remove dents where possible.
2. Remove and repair hinges if worn or damaged.

C. REMOVAL

Lift door off hinge pins.

D. INSTALLATION

Place door in hinges over hinge pins and install in place.

END OF TASK

3-16. DOOR LOCK**3-16**

This task covers: A. INSPECTION B. REMOVAL C. INSTALLATION

INITIAL SETUP

Tools

Tool Kit, Aircraft Mechanics General, NSN 5180-00-323-4692

Personnel Required

MOS 67

Reference InformationParagraph 3-15 Illustration

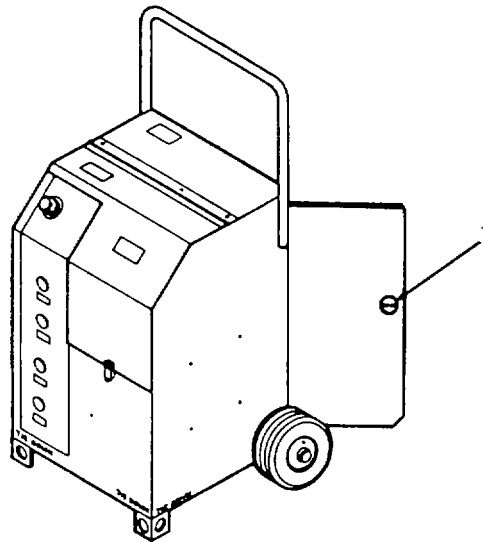

A. INSPECTION

Inspect door lock (1) for damage or wear and locking.

B. REMOVAL

1. Remove attaching hardware securing damaged door lock.
2. Remove damaged door lock.

C. INSTALLATION

1. Replace door lock.
2. Align properly and tighten as necessary.

END OF TASK

3-17. GEAR PUMP**3-17**

This task covers: A. INSPECTION B. REMOVAL C. INSTALLATION

INITIAL SETUPTools

Tool Kit, Hydraulic, NSN 5180-00-323-4891

Personnel Required

MOS 68H

General Safety Instructions

WARNING

Be sure that all electrical power is removed from the unit before beginning any maintenance operation.

NOTE

Tag all disconnected wiring and tubes to ease reinstallation. Ensure that hydraulic fluid is drained from the reservoir.

GO TO NEXT PAGE

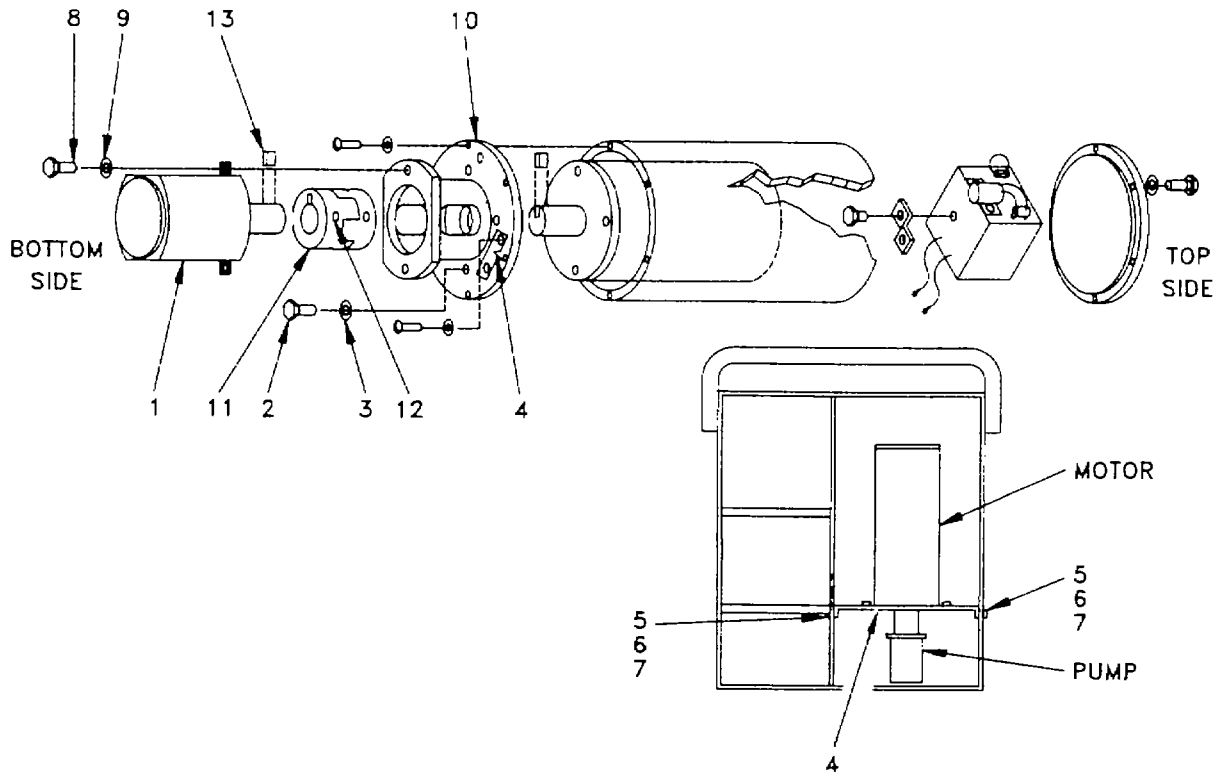

A. INSPECTION

1. Check performance of hydraulic gear pump (1) during normal operation of hydraulic cart.
2. Check for leaks, damage, or loose connections at pump connection ports.

B. REMOVAL

NOTE

The gear pump and electric motor will be removed and installed as an assembly.

1. Disconnect all hydraulic tubings from the gear pump (1).
2. Remove the two fittings connected to the gear pump.
3. Remove four screws (2) and lock washers (3) securing the motor/pump assembly to the motor bracket (4).

GO TO NEXT PAGE

3-17. GEAR PUMP - Continued

3-17

4. Disconnect electrical wiring from motor/pump assembly at junction box. Tag the tree wires.
5. Remove two front capscrews (5), lockwashers (6), and nuts (7) securing motor bracket (4) to the cabinet and lower tray. Loosen two rear nuts (7) and tilt motor bracket to remove motor/pump assembly till gear pump is clear of the motor bracket. Lay motor assembly to a side to remove gear pump.
6. Remove two capscrews (8) and lock washers (9) and separate gear pump from pump adapter (10). Pump half coupling (11) will slide out with pump.
7. Loosen allen screw (12) and pull coupling (11) from pump shaft.
8. Lift key (13) from pump shaft.

C. INSTALLATION

1. Place key (13) in the slot of pump shaft.
2. Slide pump half coupling (11) on key and secure with allen screw (12).
3. Slide gear pump (1) through pump adapter (10) and ensure that the two coupling halves and rubber spider are properly seated.
4. Secure gear pump to pump adapter with two capscrews (8) and lock washers (9).
5. Lift motor/pump assembly and slide gear pump through motor bracket (4). Ensure pump is correctly positioned to connect to respective tubes.
6. Reconnect electrical wiring at junction box from motor/pump assembly. Secure motor bracket (4) to cabinet and lower tray with capscrews (5), lock washers (6), and nuts (7).
7. Secure motor/pump assembly to motor bracket with four screws (2) and lock washers (3).
8. Install the two fittings in the gear pump.
9. Connect hydraulic tubing to the gear pump.

END OF TASK

3-18. PRESSURE GAGE**3-18**

This task covers:

A. INSPECTION

B. REMOVAL

C. CALIBRATION

D. INSTALLATION

INITIAL SETUPTools

Tool Kit, Instruments, NSN 5180-00-323-4913

Personnel Required

MOS 67 and MOS 68X

General Safety Instructions**WARNING**

Be sure that all electrical power is removed from the unit before beginning any maintenance operation.

To avoid personnel injury, the pump must be shut down before beginning any maintenance operation.

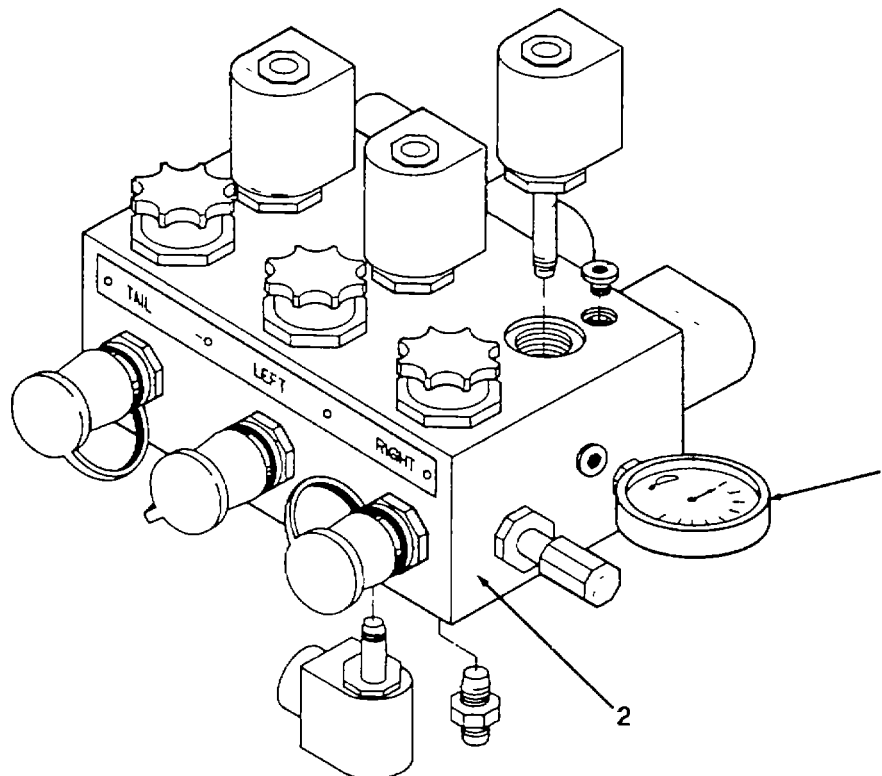

GO TO NEXT PAGE

3-18. PRESSURE GAGE - Continued

3-18**A. INSPECTION**

1. Check pressure gage (1) for physical damage.
2. Check gage for accuracy at regular Intervals by removing it and comparing against a standard gage.

B. REMOVAL

1. Disconnect inlet tube at filter inlet, next to the pressure gage (1).
2. Unscrew pressure gage (1) from manifold (2).

C. CALIBRATION (USATSG)

Calibration will be performed by the U.S. Army, Test, Measurement and Diagnostic Equipment, Support Group in accordance with the standard practice.

D. INSTALLATION

1. Screw pressure gage (1) in manifold (2) and turn till the gage can be properly seen when tightened.
2. Reconnect inlet tube at filter inlet, next to the pressure gage (1).

END OF TASK

3-19. RELIEF VALVE**3-19**

This task covers:	A. INSPECTION	B. ADJUSTMENT	C. REMOVAL
	D. REPAIR (AVIM)	E. INSTALLATION	

INITIAL SETUPTools

Shop Set, AVIM, Hydraulic, NSN 4920-00-165-1454

Personnel Required

MOS 68H

Parts Required

'O' Ring, MS28778-10

'O' Ring, MS28775-014

Back-up Washer, MS28774-014

Relief Valve, RV6-10-C-0-100-3000PSI

General Safety Instructions**WARNING**

Be sure that all electrical power is removed from the unit before beginning any maintenance operation.

To avoid personnel injury, the pump must be shut down before beginning any maintenance operation.

A. INSPECTION

1. Check condition of relief valve (1) for damage, loose connection, and leaks.
2. Check adjustment at regular intervals.

B. ADJUSTMENT

1. Run pump and read pressure on pressure gage (2). If below 3,000 psig, stop pump and perform following steps. See Chapter 2 operating instructions.
2. Unscrew cap of relief valve (1). Loosen locknut and turn adjusting screw with 3/8 inch allen key.

GO TO NEXT PAGE

3-19. RELIEF VALVE -Continued**3-19**

3. Perform steps 1 and 2 until correct set pressure is obtained.
4. Tighten locknut while ensuring adjusting screw does not move.
5. Screw relief valve cap back in place.

C. REMOVAL

Unscrew relief valve (1) from manifold (3).

D. REPAIR (AVIM)

1. If 'O' rings or back-up washer are damaged, remove 'O' rings and back-up washer.
2. Replace 'O' rings or back-up washer as required.
3. If 'O' rings are not defective and some other fault exists, replace relief valve.

E. INSTALLATION

Screw repaired or new relief valve (1) in manifold (3) and tighten.

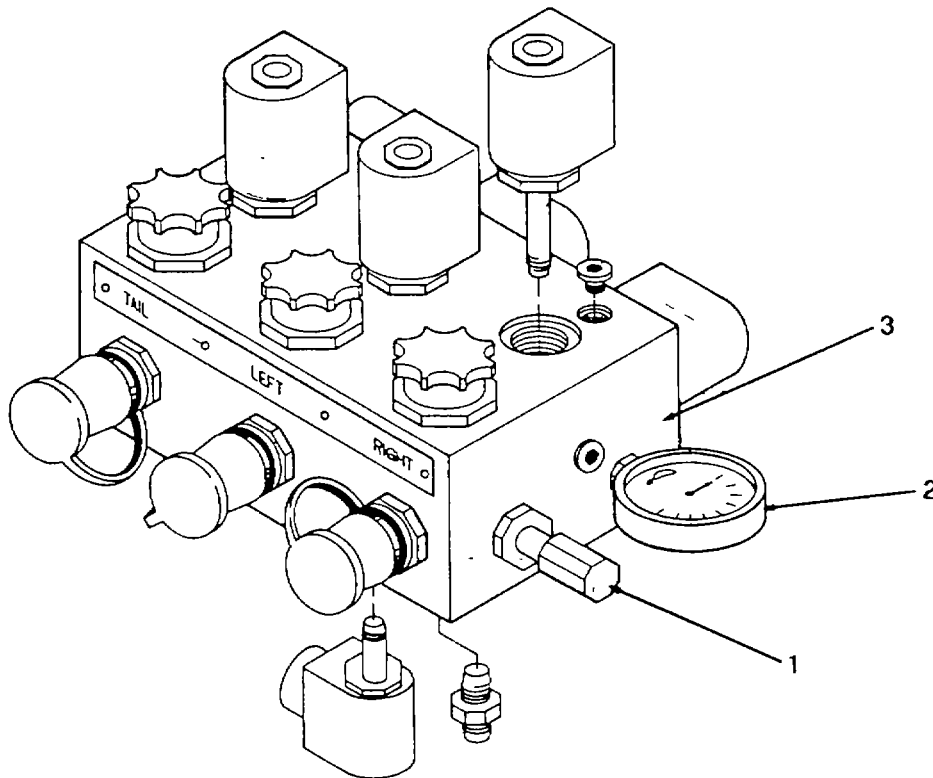

END OF TASK

3-20. SOLENOID VALVE

3-20

This task covers:	A. INSPECTION	B. REMOVAL	C. REPAIR (AVIM)
	D. INSTALLATION		

INITIAL SETUP

Tools

Shop Set, AVIM, Electrical/Instrument, NSN 4920-00-165-1453
 Shop Set, AVIM, Hydraulic, NSN 4920-00-165-1454

Personnel Required

MOS 68H and MOS 68X

Parts Required

'O' Ring, MS28778-10
 'O' Ring, MS28775-014
 Back-Up Washers, MS28774-014
 Solenoid Valve, SV3-10-C-0-24DW
 Solenoid Valve, SV4-10-0-24DP

General Safety Instructions

WARNING

Be sure that all electrical power is removed from the unit before beginning any maintenance operation.

To avoid personnel injury, the pump must be shut down before beginning any maintenance operation.

A. INSPECTION

Check condition of solenoid valve (1 or 2) for damage, loose connections, and leaks.

B. REMOVAL

1. Remove attaching hardware securing solenoid coil (1 or 2) and lift off solenoid coil and place it to a side.
2. Unscrew solenoid valve (3 or 4) from manifold (5).

GO TO NEXT PAGE

3-20. SOLENOID VALVE - Continued**3-20****C. REPAIR (AVIM)**

1. If 'O' rings are damaged, remove 'O' rings and back-up washers.
2. Replace 'O' rings and back-up washers.
3. If 'O' rings are not defective, and some other fault exists, replace solenoid valve.

D. INSTALLATION

1. Install repaired or new solenoid valve (3 or 4) in manifold (5) and tighten.
2. Place solenoid coil (1 or 2) on top of solenoid valve (3 or 4) and secure with attaching hardware.

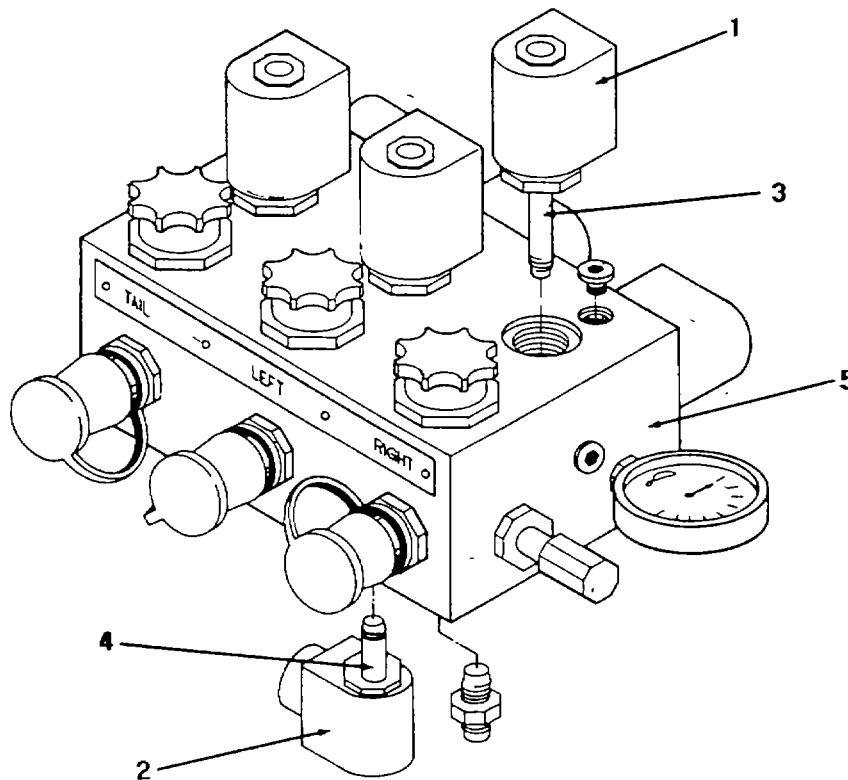

END OF TASK

3-21. QUICK DISCONNECT**3-21**

This task covers: A. INSPECTION B. REMOVAL C. INSTALLATION

INITIAL SETUP

Tools

Tool Set, AVUM Set No. 2, NSN 4920-00-567-0476

Personnel Required

MOS 68H

Parts Required

'O' Ring Gasket, MS29512-4

Reference Information

Paragraph 3-22 Illustration

General Safety Instructions

WARNING

Be sure that all electrical power is removed from the unit before beginning any maintenance operation.

To avoid personnel injury, the pump must be shut down before beginning any maintenance operation.

A. INSPECTION

1. Check condition of quick disconnect (1) for damage, loose connections, and leaks.
2. If damaged, replace quick disconnect.

B. REMOVAL

1. Loosen jam nut (2) behind quick disconnect (1).
2. Unscrew quick disconnect (1) from manifold (3).
3. Remove 'O' ring gasket (4) and jam nut (2) from quick disconnect (1).

C. INSTALLATION

1. Install jam nut (2) on quick disconnect (1) followed by 'O' ring gasket (4).
2. Screw quick disconnect (1) in manifold (3) as far as it will go.
3. Tighten jam nut (2) on quick disconnect (1).

END OF TASK

3-22. NEEDLE VALVE KNOB**3-22**

This task covers: A. INSPECTION B. REMOVAL C. INSTALLATION

INITIAL SETUPTools

Tool Kit, Instrument, NSN 5180-00-323-4913

Personnel Required

MOS 67

A. INSPECTION

1. Check for damaged, loose, or missing needle valve knob (5).
2. Tighten loose knob.

B. REMOVAL

1. Remove attaching hardware securing damaged knob (5).
2. Remove damaged needle valve knob.

C. INSTALLATION

1. Replace damaged or missing needle valve knob (5).
2. Align properly and tighten attaching hardware as necessary.

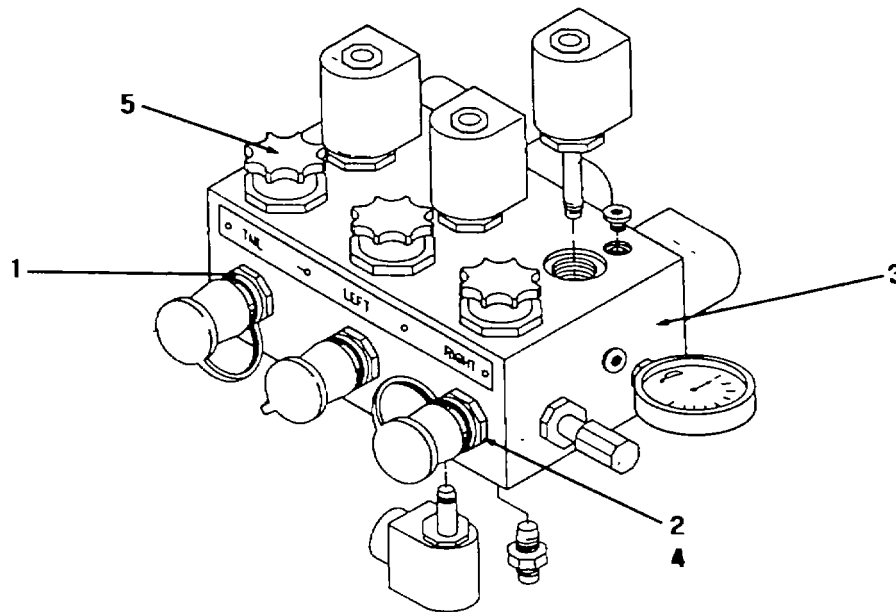

END OF TASK

3-23. NEEDLE VALVE

3-23

This task covers: A. INSPECTION B. REMOVAL C. REPAIR (AVIM)
 D. INSTALLATION

INITIAL SETUP

Tools

Shop Set, AVIM, Hydraulic, NSN 4920-00-165-1454

Personnel Required

MOS 68H

Parts Required

'O' Ring, MS28778-10

'O' Ring, MS28775-014

Back-up Washers, MS28774-014

Needle Valve, NV1-10-K-0

General Safety Instructions

WARNING

Be sure that all electrical power is removed from the unit before beginning any maintenance operation.

To avoid personnel injury, the pump must be shut down before beginning any maintenance operation.

A. INSPECTION

Check condition of needle valve (1) for damage, loose connections, and leaks.

B. REMOVAL

Unscrew needle valve (1) from manifold (2).

GO TO NEXT PAGE

3-23. NEEDLE VALVE - Continued**3-23****C. REPAIR (AVIM)**

1. If 'O' rings or back-up washers are damaged, remove 'O' rings and back up washers.
2. Replace 'O' rings or back-up washers.
3. If 'O' rings are not defective and some other fault exists, replace needle valve.

D. INSTALLATION

Install repaired or new needle valve (1) in manifold (2) and tighten.

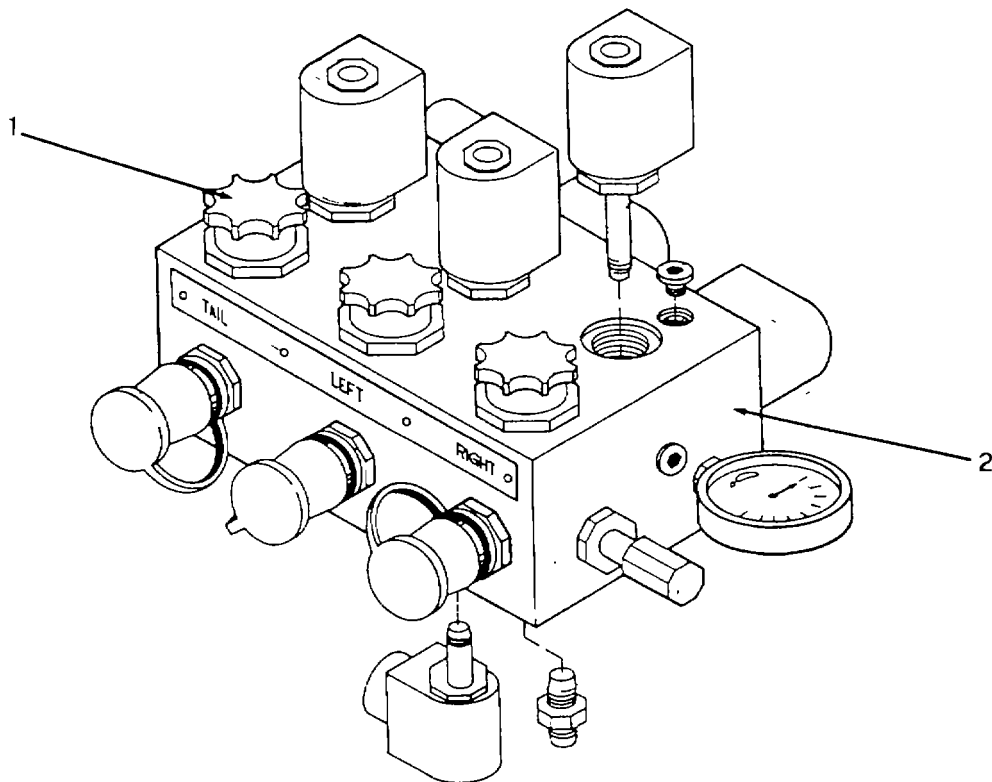

END OF TASK

3-24. CHECK VALVE**3-24**

This task covers: A. INSPECTION B. REMOVAL C. REPAIR (AVIM)
 D. INSTALLATION

INITIAL SETUPTools

Shop Set, AVIM, Hydraulic, NSN 4920-00-165-1454

Personnel Required

MOS 68H

Parts Required

'O' Ring, MS28778-10
 'O' Ring, MS28775-014
 Back-up Washer, MS28774-014
 Needle Valve, CV1-10-B-0-5

General Safety Instructions**WARNING**

Be sure that all electrical power is removed from the unit before beginning any maintenance operation.

To avoid personnel injury, the pump must be shut down before beginning any maintenance operation.

A. INSPECTION

Check condition of check valve (1) for damage, loose connections, and leaks.

B. REMOVAL

1. Remove solenoid coil (2) from solenoid valve.
2. Unscrew check valve (1) from manifold (3).

GO TO NEXT PAGE

GO TO NEXT PAGE

3-24. CHECK VALVE - Continued

3-24

C. REPAIR (AVIM)

1. If 'O' rings or back-up washer are damaged, remove 'O' rings and back up washer.
2. Replace 'O' rings and back-up washer.
3. If 'O' rings are not defective and some other fault exists, replace check valve.

D. INSTALLATION

1. Screw repaired or new check valve (1) in manifold (3) and tighten.
2. Install solenoid coil (2) on solenoid valve.

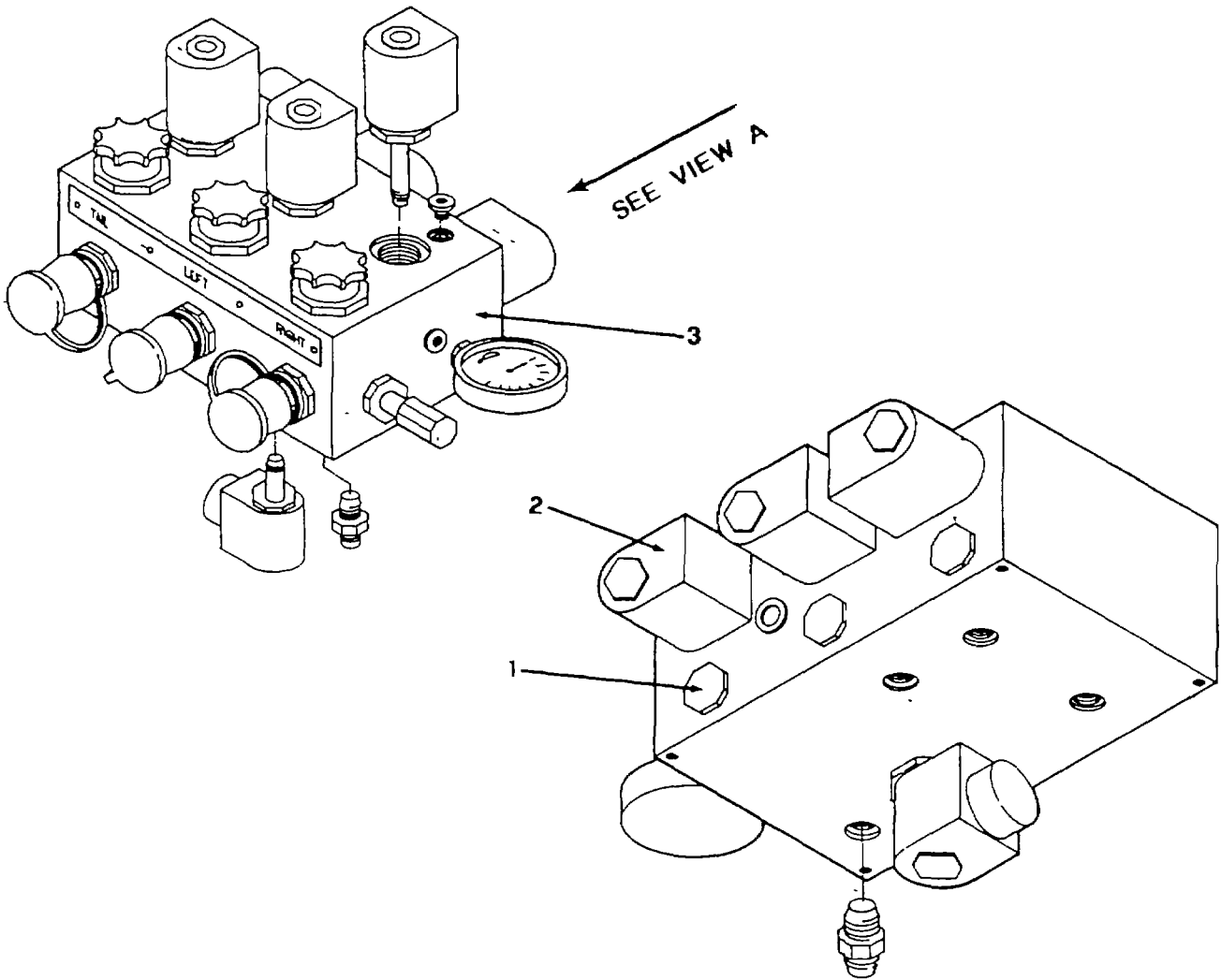

END OF TASK

3-25. MANIFOLD

3-25

This task covers: A. INSPECTION B. REMOVAL (AVIM)
 C. INSTALLATION (AVIM)

INITIAL SETUP

Tools

Shop Set, AVIM, Hydraulic, NSN 4920-00-165-1454

Personnel Required

MOS 68H

Equipment Condition

Manifold disassembled

Reference Information

Appendix C, Figure 6

Equipment Condition Paras

3-18 through 3-24

General Safety Instructions

WARNING

Be sure that all electrical power is removed from the unit before beginning any maintenance operation.

To avoid personnel injury, the pump must be shut down before beginning any maintenance operation.

NOTE

Tag all disconnected wiring and tubes to ease reinstallation.

A. INSPECTION

Check condition of manifold for cracks, fracture, or damage.

B. REMOVAL (AVIM)

1. Remove attaching hardware securing solenoid coils and lift off solenoid coils.
2. If coils have to be removed, remove attaching hardware and wire lugs from junction box for the respective solenoids and remove solenoid coils.

GO TO NEXT PAGE

3-25. MANIFOLD - Continued

3-25

3. Disconnect four tubes connecting at the bottom of manifold.
4. Remove four nuts and lockwashers holding the manifold at the bottom.
5. Lift off manifold assembly, from the cart cabinet. Unscrew four standoffs from manifold.
6. Remove five hollow plugs and four straight adapters from manifold.

C. INSTALLATION (AVIM)

1. Install four straight adapters and five hollow plugs in manifold.
2. Install components in manifold in accordance with paragraphs 3-18 through 3-24.
3. Screw standoffs in manifold.
4. Secure manifold to cabinet with four nuts and lockwashers. Do not tighten fully.
5. Connect four tubes at the bottom of manifold. (See Figure 6 in Appendix C for location.)
6. Fully tighten tubes and manifold mounting nuts.
7. Place solenoid coils on solenoid valves and secure with attaching hardware.
8. If removed, reconnect solenoid coil wire lugs in junction box.

END OF TASK

3-26. FILTER

3-26

This task covers:	A. INSPECTION	B. SERVICE	C. REMOVAL
	D. INSTALLATION	E. TEST	

INITIAL SETUPTools

Tool Kit, Aircraft Mechanics General, NSN 5180-00-323-4692

Material Required

Antiseize tape MIL-T-27730
Cleaning solvent P-D-680, Type II
Clean cloth

Parts Required

Filter element 0060D010BN/HC
Filter DFBN/HC30G3B1.0/12

Personnel Required

MOS 67

General Safety Instructions

WARNING

Test cart must be shut down before servicing filter.

Use volatile solvents only in a well ventilated area. Avoid prolonged contact with the skin.

NOTE

Tag all disconnected tubing and lines to ease reinstallation.

GO TO NEXT PAGE

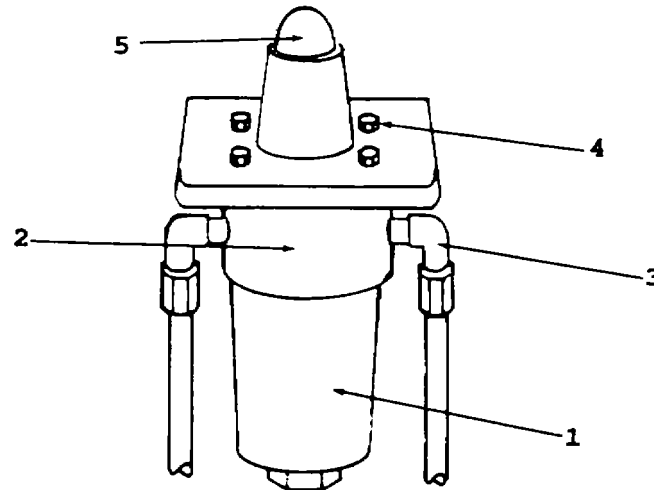

A. INSPECTION

1. Check to see if red marker is extended in the clogging indicator.
2. If extended, it indicates a dirty filter element in need of replacement.

B. SERVICE

1. Unscrew filter bowl (1) and remove.
2. Remove filter element.
3. Empty fluid from bowl.
4. Clean head assembly (2) and bowl (1) with cleaning solvent P-D-680, Type II and clean cloth.
5. Install replacement filter element, 0060D010BN/HC.
6. Fill bowl approximately 3/4 full with hydraulic fluid and install.

C. REMOVAL

1. Disconnect hydraulic lines from filter. Retain straight thread elbows (3) with filter assembly.
2. Remove four bolts (4) holding filter assembly to mounting bracket.
3. Remove filter assembly.
4. Remove straight thread elbows from input and output sides of filter assembly. Remove clogging indicator assembly (5) from top of filter assembly.
5. Discard defective filter assembly.

GO TO NEXT PAGE

D. INSTALLATION**NOTE**

Antiseize tape shall be applied to male threads prior to installation of elbows. Ensure tape does not cover the first thread. All connections should be tightened as necessary to preclude leakage of hydraulic fluid.

1. Use antiseize tape, MIL-T-27730, on all hydraulic connections.
2. Install straight thread elbows (3) into input and output sides of filter.
3. Position filter, and make sure that flow direction (arrow) is correct. Attach to mounting bracket using four bolts (4).
4. Connect input and output hydraulic tubing/lines. Install clogging indicator assembly (5).

E. TEST

Pressurize system and check for leaks at filter. See Chapter 2, Operating Instructions.

END OF TASK

3-27. FILLER/BREATHER AND SPECIAL ADAPTER

3-27

This task covers: A. INSPECTION B. REMOVAL C. INSTALLATION

INITIAL SETUP

Tools

Tool Kit, Hydraulic, NSN 5180-00-323-4891

Personnel Required

MOS 67 and MOS 68H

General Safety Instructions

WARNING

Be sure that all electrical power is removed from the unit before beginning any maintenance operation.

To avoid personnel injury, the pump must be shut down before beginning any maintenance operation.

A. INSPECTION

Unscrew filler/breather cap (1) and inspect special adapter (2) and strainer for physical damage.

B. REMOVAL

1. Unscrew drain plug (3) at the bottom of reservoir tank (4) and drain it. Reservoir tank contains approximately 5 gallons of hydraulic fluid if level is till REMOVE FLUID sight glass.
2. Remove six screws (5) and lock washers (6) and lift off reservoir cover (7). Be careful gasket (8) may come out with the reservoir cover (7).
3. Remove six nuts (9), lock washers (10), and screws (11).
4. Lift off filler/breather (1) and special adapter (2) along with lanyard (12) from reservoir cover (7).

GO TO NEXT PAGE

3-27. FILLER/BREATHER AND SPECIAL ADAPTER - Continued**3-27****C. INSTALLATION**

1. Position filler/breather (1) and special adapter (2) along with lanyard (12) on reservoir cover (7).
2. Secure filler/breather (1) with six screws (11), lock washers (10), and nuts (9).
3. If gasket (8) was removed, place it such that the holes match at the reservoir opening.
4. Place reservoir cover (7) on reservoir opening and secure with six lock washers (6) and screws (5).
5. Install drain plug (3) at the bottom of reservoir tank (4). Ensure it is tightened fully.
6. Fill reservoir tank to the center of the OPNL LEVEL sight glass (13) with MIL-H-5606 or MIL-H-83282 hydraulic fluid.

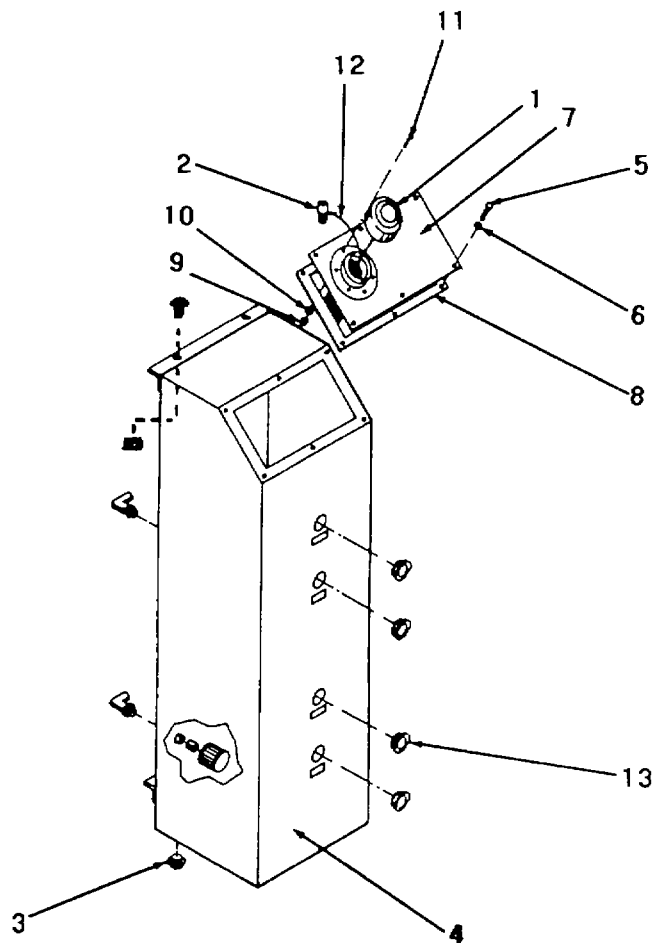

END OF TASK

3-28. FLUID LEVEL SIGHT GLASS**3-28**

This task covers: A. INSPECTION B. REMOVAL C. INSTALLATION

INITIAL SETUP

Tools

Tool Kit, Hydraulic, NSN 5180-00-323-4891

Personnel Required

MOS 67

General Safety Instructions

WARNING

Be sure that all electrical power is removed from the unit before beginning any maintenance operation.

To avoid personnel injury, the pump must be shut down before beginning any maintenance operation.

GO TO NEXT PAGE

3-28. FLUID LEVEL SIGHT GLASS - Continued**3-28****A. INSPECTION**

Inspect REMOVE FLUID, FULL LEVEL, OPNL LEVEL, and LOW LEVEL sight glasses (1) for cracks, damaged rubber gasket, broken glass, or physical damage.

B. REMOVAL

1. Unscrew drain plug (2) at the bottom of reservoir tank (3) and drain it. Reservoir tank contains approximately 5 gallons of hydraulic fluid.
2. Remove six screws (4) and lock washers (5) and lift off cover (6) from reservoir tank.
3. Remove attaching locknut from inside the reservoir tank and remove sight glass (1).

C. INSTALLATION

1. Install sight glass (1) in reservoir tank (3) and secure with attaching locknut.
2. Install cover (6) on reservoir tank with screws (4) and lock washers (5).
3. Install drain plug (2) at the bottom of reservoir tank. Ensure it is tightened fully.
4. Fill reservoir tank to the center of the OPNL LEVEL sight glass (1) with MIL-H-5606 or MIL-H-83282 hydraulic fluid.

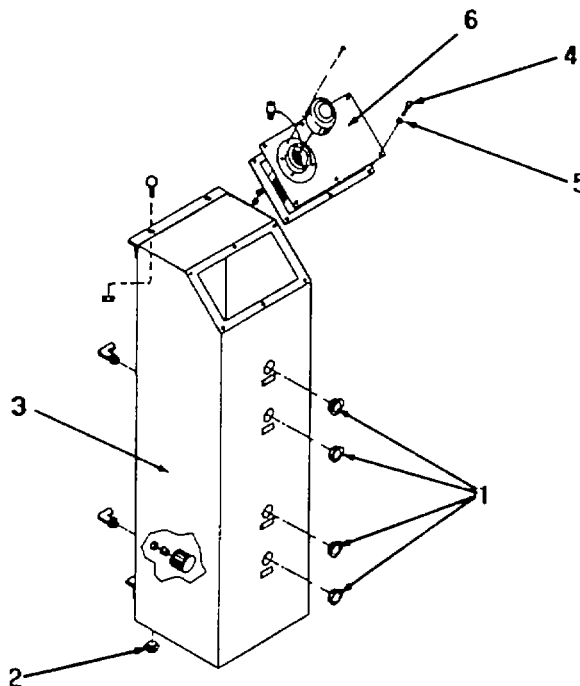

END OF TASK

3-29. SUCTION STRAINER

3-29

This task covers: A. INSPECTION B. REMOVAL C. CLEANING
 D. INSTALLATION

INITIAL SETUPTools

Tool Kit, AVUM Set No. 2, NSN 4920-00-567-0476
Flashlight

Materials Used

Cleaning Solvent, P-D-680, Type II
Clean Cloth

Personnel Required

MOS 67

General Safety Instructions

WARNING

Be sure that all electrical power is removed from the unit before beginning any maintenance operation.

To avoid personnel injury, the pump must be shut down before beginning any maintenance operation.

GO TO NEXT PAGE

3-29. SUCTION STRAINER - Continued

3-29**A. INSPECTION**

Inspect suction strainer (1) under powerful light after draining reservoir tank (2). Dirt on it requires cleaning of the strainer.

B. REMOVAL

1. Unscrew drain plug (3) at the bottom of reservoir tank (2) and drain it. Reservoir tank contains approximately 5 gallons of hydraulic fluid at REMOVE FLUID sight glass level.
2. Remove six screws (4) and lock washers (5) and lift off cover (6) from reservoir tank (2).
3. Unscrew suction strainer (1) from pipe nipple (7).

C. CLEANING**WARNING**

Use volatile solvents only in a well ventilated area. Avoid prolonged contact with the skin.

1. Clean suction strainer (1) with cleaning solvent, P-D-680, Type II and clean cloth.
2. Dry it using low pressure compressed air.

D. INSTALLATION

1. Install suction strainer (1) on pipe nipple (7) in reservoir tank (2).
2. Install cover (6) on reservoir tank with screws (4) and lock washers (5).
3. Install drain plug (3) at the bottom of reservoir tank. Ensure it is tightened fully.
4. Fill reservoir tank to the center of the OPNL LEVEL sight glass (8) with MIL-H-5606 or MIL-H-83282 hydraulic fluid.

GO TO NEXT PAGE

3-29. SUCTION STRAINER - Continued

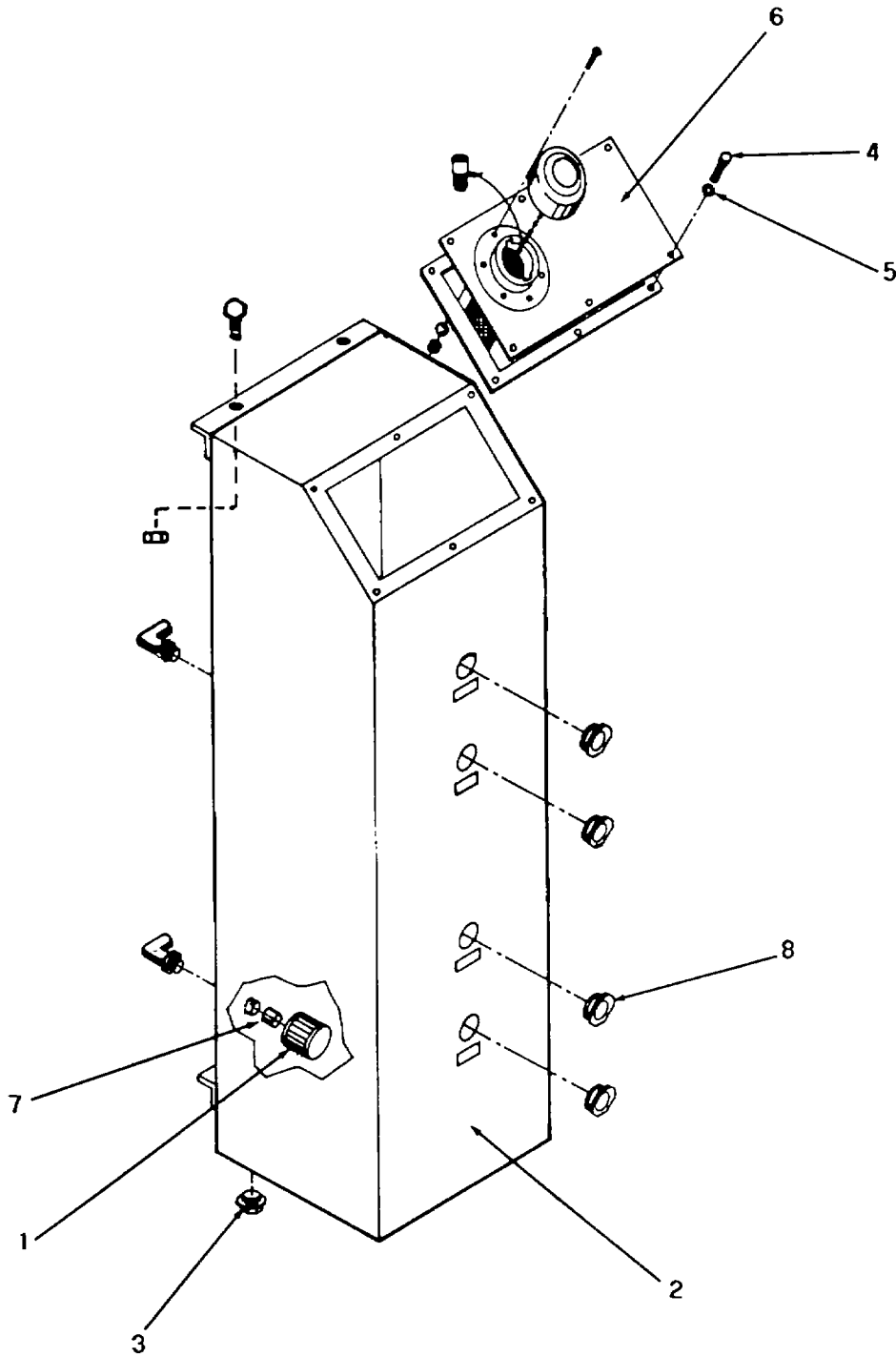

END OF TASK

3-30. RESERVOIR TANK

3-30

This task covers: A. INSPECTION B. REPAIR (AVIM) C. REMOVAL
 D. INSTALLATION

INITIAL SETUPTools

Tool Kit, Hydraulic, NSN 5180-00-323-4891
Shop Set, AVIM, Hydraulic, NSN 4920-00-165-1454

Parts Required

Gasket, P/N 20079-03

Personnel Required

MOS 67

General Safety Instructions

WARNING

Be sure that all electrical power is removed from the unit before beginning any maintenance operation.

To avoid personnel injury, the pump must be shut down before beginning any maintenance operation.

NOTE

Tag all disconnected tubing to ease reinstallation.

A. INSPECTION

1. Check fluid level to make sure it is to the center of the OPNL LEVEL sight glass (1).
2. Check all tubing and line connections for leaks.
3. Check reservoir tank (2) for physical damage.

GO TO NEXT PAGE

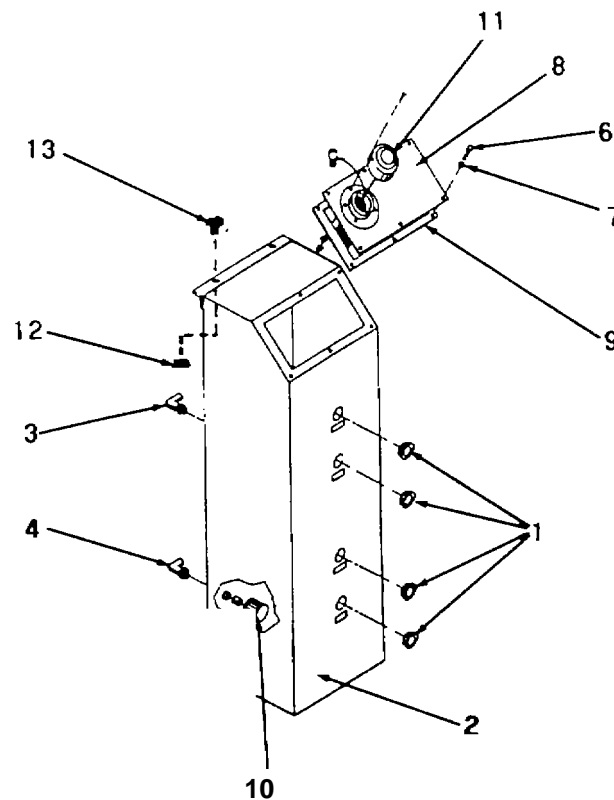

3. REPAIR (AVIM)

CAUTION

When moving reservoir tank (2), care should be taken to avoid damaging fittings (3 and 4).

1. Unscrew drain plug (5) at the bottom of reservoir tank (2) and drain it. Reservoir tank contains approximately 5 gallons of hydraulic fluid at REMOVE FLUID sight glass (1) level.
2. Remove six screws (6) and lock washers (7) and lift off cover (8) from reservoir tank.
3. Discard gasket (9).
4. Clean and inspect interior.
5. Check suction strainer (10), filler/breather (11), and sight glasses (1).
6. Repair any damage or replace broken parts as necessary.
7. Install new gasket (9).

GO TO NEXT PAGE

3-30. RESERVOIR TANK - Continued

3-30

8. Install cover (8) on reservoir tank (2) with screws (6) and lock washers (7).
9. Install drain plug (5) at the bottom of reservoir tank. Ensure it is tightened fully.
10. Fill reservoir tank to the center of the OPNL LEVEL sight glass (1) with MIL-H-5606 or MIL-H-83282 hydraulic fluid.

C. REMOVAL

1. Unscrew drain plug (5) at the bottom of reservoir tank (2) and drain it. Reservoir tank contains approximately 5 gallons of hydraulic fluid at REMOVE FLUID sight glass (1) level.
2. Disconnect return line from upper fitting (3) and suction line from lower fitting (4).
3. Remove four mounting nuts (12) and screws (13).

CAUTION

When moving reservoir tank (2), care should be taken to avoid damaging fittings (3 and 4).

4. Remove reservoir tank off the hydraulic cart.

D. INSTALLATION**CAUTION**

When moving reservoir tank (2), care should be taken to avoid damaging fittings (3 and 4).

1. Position reservoir tank (2) on hydraulic cart.
2. Install four mounting screws (13) and nuts (12).
3. Connect return line at upper fitting (3) and suction line at lower fitting (4).
4. Install drain plug (5) at the bottom of reservoir. Ensure it is tightened fully.
5. Fill reservoir tank to the center of the OPNL LEVEL sight glass (1) with MIL-H-5606 or MIL-H-83282 hydraulic fluid.

END OF TASK

3-31. HYDRAULIC PIPING**3-31**

This task covers:	A. INSPECTION	B. REPAIR (AVIM)	C. REMOVAL
	D. INSTALLATION	E. TEST (AVIM)	

INITIAL SETUPTools

Tool Kit, Hydraulic, NSN 5180-00-323-4891
 Shop Set, AVIM, Hydraulic, NSN 4920-00-165-1454

Personnel Required

MOS 67 and MOS 68H

General Safety Instructions**WARNING**

Be sure that all electrical power is removed from the unit before beginning any maintenance operation.

To avoid personnel injury, the pump must be shut down before beginning any maintenance operation.

NOTE

Tag all disconnected tubing and lines to ease reinstallation.

A. INSPECTION

Check all hydraulic lines, tubing, fittings, and manifold for damage, loose connections, and leakage.

B. REPAIR (AVIM)

1. Repair or replace all damaged or worn lines, tubing, fittings, and manifold.
2. Tighten all loose connections.

C. REMOVAL

Disconnect and remove hydraulic lines, tubing, fittings, and manifold only to the extent necessary for the repair or replacement of damaged or worn parts.

GO TO NEXT PAGE

3-31. HYDRAULIC PIPING - Continued

3-31**D. INSTALLATION**

Install all hydraulic lines, tubing, fittings, and manifold that have been removed for repair or replacement.

E. TESTING (AVIM)

Test piping assembly for leakage while operating hydraulic cart under full flow and pressure conditions. See Chapter 2, Operating Instructions.

END OF TASK

3-32. DC MOTOR

3-32

This task covers: A. INSPECTION B. REMOVAL C. REPAIR (AVIM)
D. INSTALLATION

INITIAL SETUPTools

Tool Kit, Aircraft Mechanics General, NSN 5180-00-323-4692

Personnel Required

MOS 67 and MOS 68X

Equipment Condition

Paragraph 3-17 Gear Pump and Motor Assembly removed
Paragraph 3-33 Flexible Coupling removed

A. INSPECTION

1. Check security of dc motor (1) mounting.
2. Check for failure of dc motor.
3. Check condition of electric wires and security of pump mounting.

B. REMOVAL

1. Remove gear pump (2) and flexible coupling (3 and 4) in accordance with procedures of paragraphs 3-17 and 3-33 removal.
2. Remove six screws (5) and lock washers (6) and lift off rear case plate (7).

NOTE

Tag all disconnected wiring to ease installation.

3. Remove attaching hardware and remove motor wire terminals. Tag them.
4. Remove six screws (8) and lock washers (9) connecting motor pump adapter (10) to case (11). Remove case (11).
5. Remove four capscrews (12) and lock washers (13) connecting motor pump adapter (10) to the cabinet.

GO TO NEXT PAGE

3-32. DC MOTOR - Continued

3-32

6. Remove attaching hardware from motor terminal connecting to bracket (14) and lift off electromagnetic interference filter (15). Ensure all connecting wires are removed and properly tagged.

C. REPAIR

1. Disassemble motor (1) by removing two bolts (16).
2. Lift brush cap assembly (17).
3. If worn out, remove attaching hardware and remove brush springs (18) and brushes (19).
4. Check bearings (20) for damage. If worn out, remove and replace bearings (20).
5. Install new brushes (19) and brush springs (18) on brush cap assembly (17).
6. Carefully Install brushes (19) around armature assembly's (21) commutator.
7. Reassemble motor (1) and secure with two bolts (16) leading into the drive end cap (22).

D. INSTALLATION

1. Place bracket (14) of electromagnetic interference filter (15) on motor and secure with motor terminal hardware. Check tags and reconnect wires removed at removal.
2. Using attaching hardware connect motor wire terminals to motor.
3. Attach pump adapter (10) to dc motor (1) with four capscrews (23) and lock washers (24).
4. Place case (11) around dc motor (1) and secure to motor pump adapter (10) with six screws (8) and lock washers (9).
5. Place rear case plate (7) on case (11) and secure with six screws (5) and lock washers (6).
6. Install flexible coupling (3 and 4) and gear pump (2) in accordance with procedures of paragraphs 3-17 and 3-33 installation.

GO TO NEXT PAGE

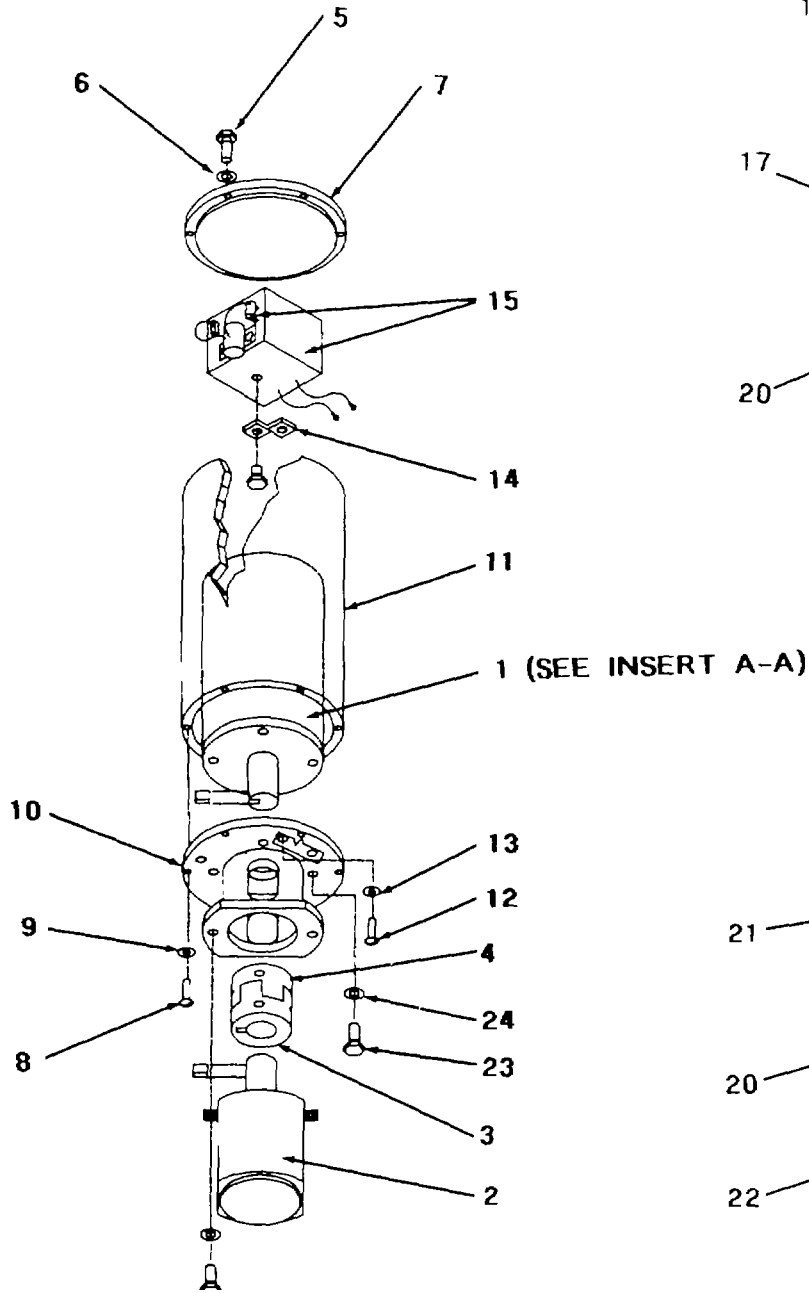

END OF TASK

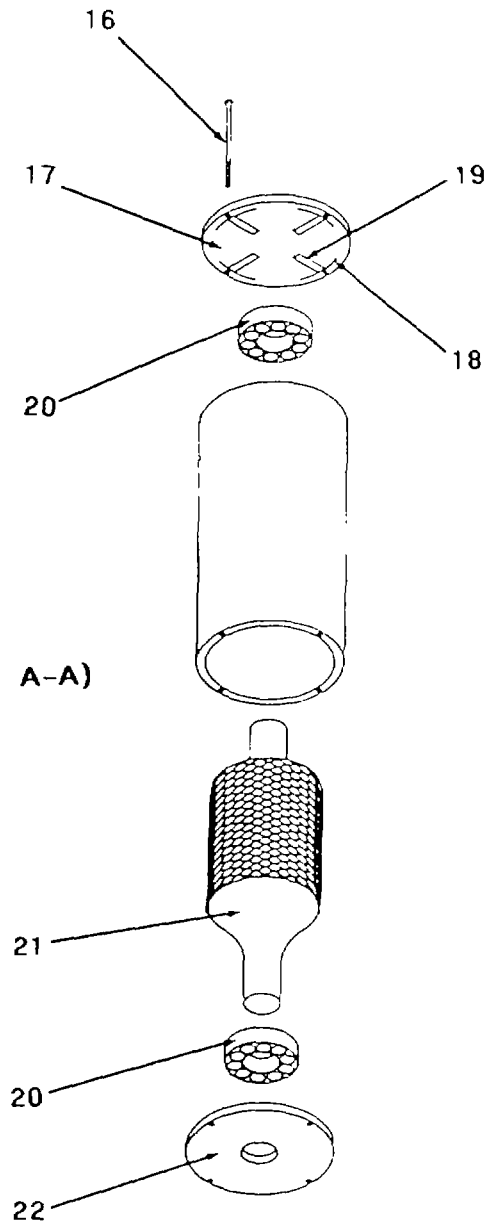

INSERT A-A

3-33. FLEXIBLE COUPLING**3-33**

This task covers: A. INSPECTION B. REMOVAL C. INSTALLATION

INITIAL SETUP

Tools

Tool Kit, AVUM Set No. 2, NSN 4920-00-567-0476

Personnel Required

MOS 67

Equipment Condition

Paragraph 3-17 Gear Pump removed

A. INSPECTION

1. Check performance of flexible coupling during normal operation of hydraulic cart.
2. Inspect coupling for missing/broken allen screws (1 and 2) or damage to the coupling halves (3 and 4).

B. REMOVAL

1. Remove pump half coupling (3) in accordance with paragraph 3-17 removal.
2. Motor half coupling (4) is removed by loosening allen screw (2) and sliding coupling half from motor shaft.
3. Remove key (5) from motor shaft.

C. INSTALLATION

1. Place key (5) in the slot of motor shaft.
2. Slide motor half coupling (4) on key and secure with allen screw (2).
3. Install pump half coupling (3) in accordance with paragraph 3-17 installation.

GO TO NEXT PAGE

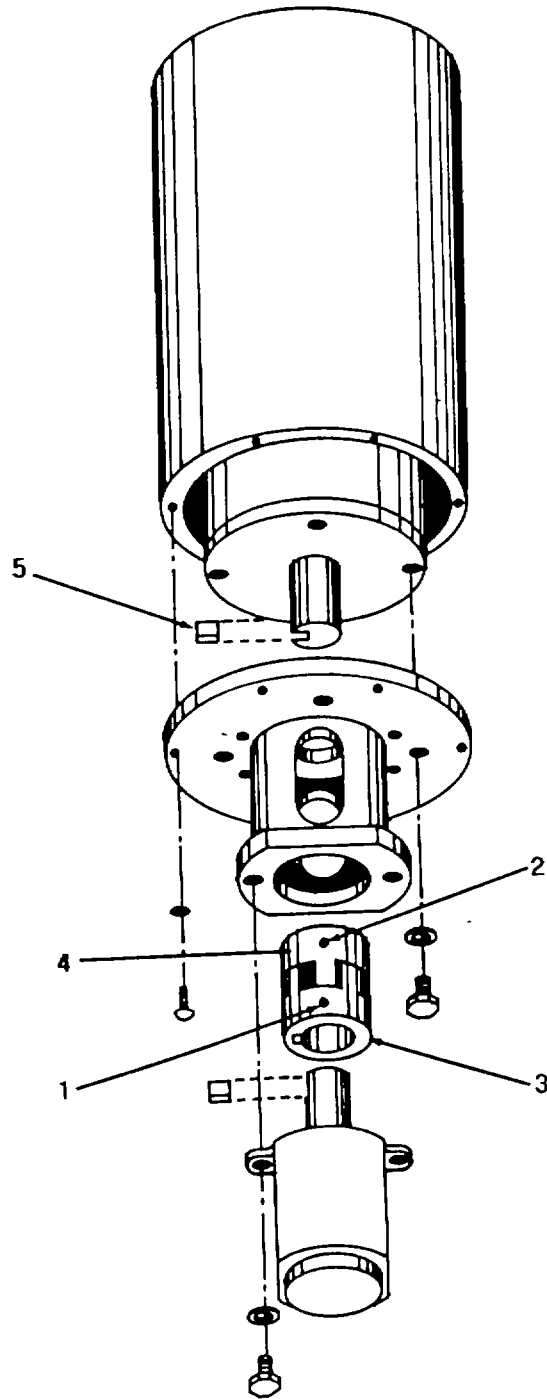

END OF TASK

3-34. START RELAY, ELECTROMAGNETIC INTERFERENCE FILTER, AND CIRCUIT BREAKER **3-34**

This task covers: A. INSPECTION B. REMOVAL C. INSTALLATION

INITIAL SETUP

Tools

Tool Kit, Electrical, NSN 5180-00-323-4915

Personnel Required

MOS 67 and MOS 68X

Equipment Condition

Motor and Pump Removed

Equipment Condition Paras.

3-17 and 3-32

General Safety Instructions

WARNING

Be sure that all electrical power is removed from the unit before beginning any maintenance operation.

A. INSPECTION

Check performance of start relay (1), electromagnetic interference filter (2), and circuit breaker (3) during normal operation or troubleshooting.

B. REMOVAL

1. Remove six screws (4) and lock washers (5) and lift off rear case plate (6).
2. Remove motor (7) from case (8) in accordance with paragraph 3-32 removal instructions.

NOTE

Tag all disconnected wiring to ease reinstallation.

3. Remove attaching hardware and remove wires from start relay (1), electromagnetic interference filter (2), and circuit breaker (3).

GO TO NEXT PAGE

**3-34. START RELAY, ELECTROMAGNETIC INTERFERENCE FILTER,
AND CIRCUIT BREAKER - Continued**

3-34

4. Remove two screws (9), flat washers (10), nuts (11), and remove start relay (1) from electromagnetic interference filter (2).
5. Remove two screws (12) and nuts (13) and remove circuit breaker (3) from electromagnetic interference filter (2).
6. Remove attaching hardware between bracket (14) and motor terminal and remove electromagnetic interference filter (2).

C. INSTALLATION

1. Attach circuit breaker (3) to electromagnetic interference filter (2) with two screws (12) and nuts (13).
2. Attach start relay (1) to electromagnetic interference filter (2) with two screws (9), flat washers (10), and nuts (11).
3. Attach electromagnetic interference filter bracket (14) to motor terminal with it's attached hardware.
4. Connect wiring to start relay (1), electromagnetic interference filter (2) circuit breaker (3) using electrical schematic (Figure 1-4) and tags as a guide.
5. Attach motor (7) to case (8) in accordance with paragraph 3-32 installation instructions.
6. Place rear case plate (6) on case (8) and secure with six screws (4) and lock washers (5).

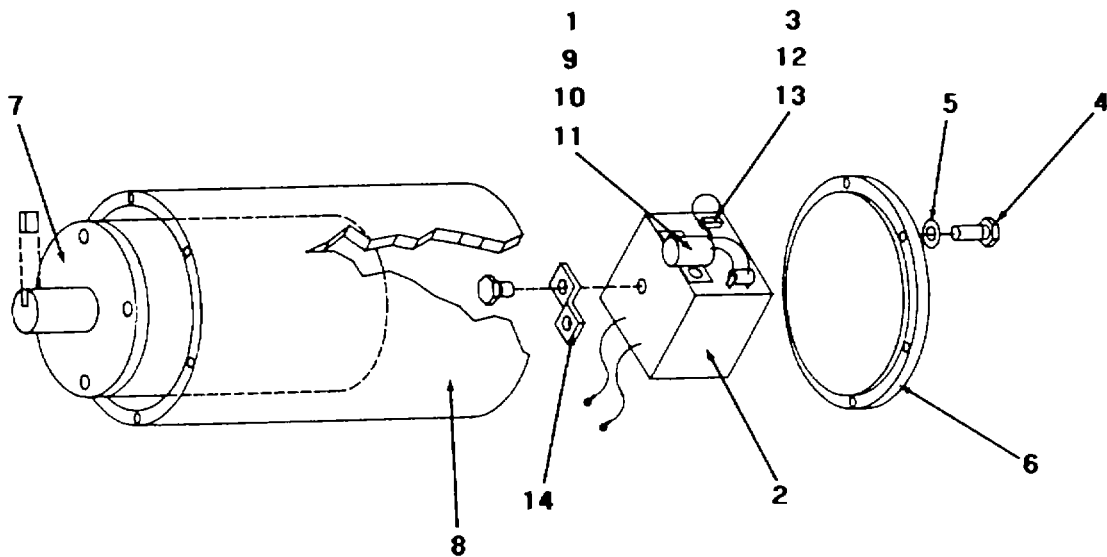

END OF TASK

3-35. INDICATOR LIGHT AND SWITCHES

3-35

This task covers: A. INSPECTION B. SERVICE C. REMOVAL
 D. INSTALLATION

INITIAL SETUP

Tools

Tool Kit, Electrical, NSN 5180-00-323-4915

Personnel Required

MOS 67 and MOS 68X

General Safety Instructions

WARNING

Be sure that all electrical power is removed from the unit before beginning any maintenance operation.

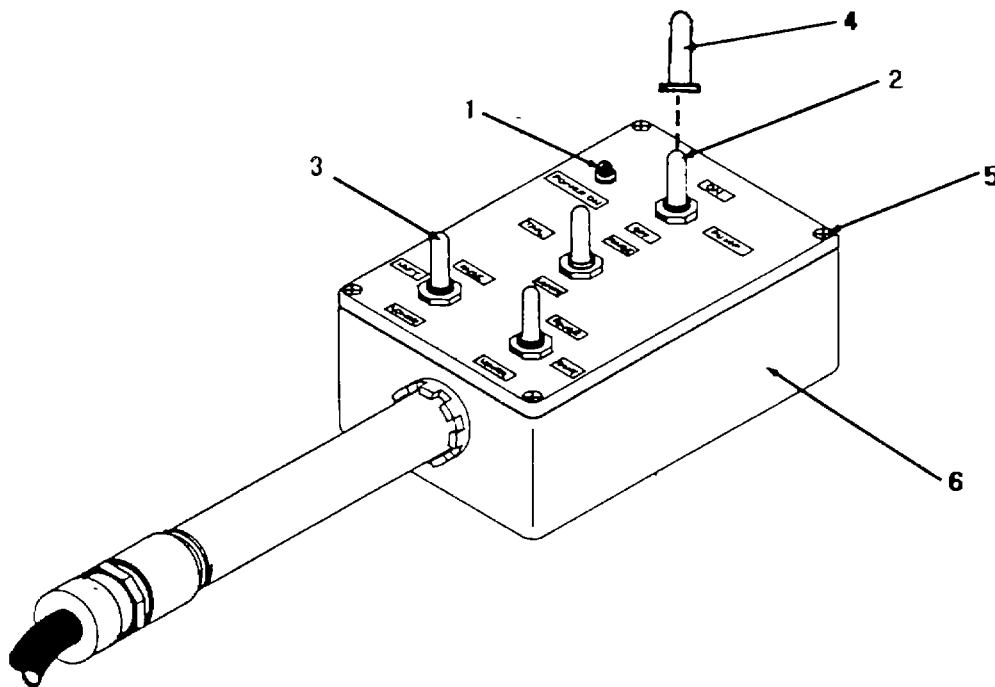

GO TO NEXT PAGE

3-35. INDICATOR LIGHT AND SWITCHES - Continued

3-35**A. INSPECTION**

1. Check indicator light (1), switches (2 and 3), and boots (4) for physical damage.
2. With power applied, check for burned out light.

B. SERVICE

1. Remove four screws (5) and raise cover of control box (6) carefully.
2. Tighten mounting hardware.
3. Tighten terminal screws.
4. Replace burned out light.

C. REMOVAL

1. Remove four screws (5) and raise cover of control box (6) carefully.

NOTE

Tag all disconnected wiring to ease reinstallation.

2. Disconnect wiring from indicator light (1) and switches (2 and 3).
3. Remove attaching hardware and remove indicator light and switches.

D. INSTALLATION

1. Install Indicator light (1) and switches (2 and 3) with attaching hardware in control box (6).
2. Connect wiring using electrical schematic and wiring diagram, Figures 1-4 and 1-5 and tags as a guide.
3. Install control box cover with four screws (5).

END OF TASK

3-36. WIRING AND CABLES**3-36**

This task covers:	A. INSPECTION	B. SERVICE	C. REPAIR (AVIM)
	D. REMOVAL (AVIM)	E. INSTALLATION (AVIM)	

INITIAL SETUPTools

Tool Kit, Electrical, NSN 5180-00-323-4915

Shop Set, AVIM, Electrical Instrument, NSN 4920-00-165-1453

Personnel Required

MOS 67 and MOS 68X

General Safety Instructions**WARNING**

Be sure that all electrical power is removed from the unit before beginning any maintenance operation.

NOTE

Tag all disconnected wiring to ease reinstallation.

A. INSPECTION

1. Remove screws and lift off control box and junction box covers.
2. Check wiring and cables for broken, loose, or grounded wires and connections.
3. Check electrical circuits with electrical system schematic and wiring diagram, Figures 1-4 and 1-5 for proper connections.

B. SERVICE

1. Tighten loose connections and terminals.
2. Replace damaged or faulty wiring, cables, and terminals if not repairable.

C. REPAIR (AVIM)

Repair damaged or loose wiring, cables, and terminals as necessary.
GO TO NEXT PAGE

3-36. WIRING AND CABLES -Continued

3-36**D. REMOVAL (AVIM)**

Disconnect both ends of damaged wires or cable and remove from hydraulic cart.

E. INSTALLATION (AVIM)

Install new wires or cable in the hydraulic cart in place of removed damaged wire or cable and connect each end of the wire to its proper place.

END OF TASK

SECTION VI. PREPARATION FOR STORAGE OR SHIPMENT

3-37. General Information. For detailed instructions for the preparation for storage or shipment, refer to TM 55-1500-204-25/1, General Aircraft Maintenance Manual and TM 743-200-1, Storage and Material Handling.

APPENDIX A

REFERENCES

A-1. Dictionaries of Terms and abbreviations.

AR 310-25..... Dictionary of United States Army Terms
 AR 310-50..... Authorized Abbreviations and Brevity Codes

A-2. Publication Index.

DA PAM 25-30 Consolidated Index of Army Publications and Blank Forms

A-3. Logistics and Storage.

TM 743-200-1..... Storage and Material Handling

A-4. Maintenance of Supplies and Equipment.

AR 750-1..... Army Material Maintenance Concepts and Policies
 DA PAM 738-751 Functional Users Manual for the Army Maintenance Management System - Aviation (TAMMS-A)
 TM 43-0139..... Painting Operations Instructions for Field Use

A-5. Other Publications.

AR 420-90..... Fire Prevention and Protection
 AR 55-38..... Report of Transportation Discrepancies in Shipment
 AR 700-58..... Packaging Improvement Report
 DA PAM 310-13 Military Publications Posting and Filing
 FM 21-11..... First Aid for Soldiers
 TB 43-180 Calibration Requirements for the Maintenance of Materiel
 TM 55-1500-204-25/1..... General Aircraft Maintenance Manual
 TM 750-244-1-4..... Procedures for the Destruction of Aviation Ground Support Equipment (FSC 1730) to Prevent Enemy Use
 TM 55-1520-238-S..... Technical Manual, Preparation For Shipment for Army AH-64A Helicopter

APPENDIX B

MAINTENANCE ALLOCATION CHART

SECTION I. INTRODUCTION

B-1. General.

- a. This section provides a general explanation of all maintenance and repair functions authorized at various maintenance categories.
- b. The Maintenance Allocation Chart (MAC) in Section II designates overall authority and responsibility for the performance of maintenance functions on the identified end item or component. The application of the maintenance functions to the end item or component will be consistent with the capacities and capabilities of the designated maintenance categories.
- c. Section III lists the tools and test equipment required for each maintenance function as referenced from Section II.
- d. Section IV contains supplemental instructions and explanatory notes for a particular maintenance function.

B-2. Maintenance Functions. Maintenance functions will be limited to and defined as follows:

- a. Inspect. To determine the serviceability of an item by comparing its physical, mechanical, and/or electrical characteristics with established standards through examination (e.g., by sight, sound, or feel).
- b. Test. To verify serviceability by measuring the mechanical, hydraulic, or electrical characteristics of an item and comparing those characteristics with prescribed standards.
- c. Service. Operations required periodically to keep an item in proper operating condition i.e., to clean, to preserve, to drain, to paint, or to replenish lubricants or fluids.
- d. Adjust. To maintain or regulate, within prescribed limits, by bringing into proper or exact position, or by setting the operating characteristics to specified parameters.
- e. Calibrate. To determine and cause corrections to be made or to be adjusted on instruments or test, measuring, and diagnostic equipments used in precision measurement. Consists of comparisons of two instruments, one of which is a certified standard of known accuracy, to detect and adjust any discrepancy in the accuracy of the instrument being compared.

f. Replace. To remove an unserviceable item and install a serviceable counterpart in its place. "Replace" is authorized by the MAC and is shown as the third position code of the SMR code.

g. Repair. The application of maintenance services, including fault location/troubleshooting, removal/installation, and disassembly/assembly procedures, and maintenance actions to identify troubles and restore serviceability to an item by correcting specific damage, fault, malfunction, or failure in a part, subassembly, module (component or assembly), end item, or system.

B-3. Explanation of Columns in the MAC, Section II.

a. Column 1, Group Number. Column 1 lists functional group code numbers, the purpose of which is to identify maintenance of significant components, assemblies, and subassemblies, with the next higher assembly. End item group number is "00".

b. Column 2, Component/Assembly. Column 2 contains the names of components, assemblies, and subassemblies for which maintenance is authorized.

c. Column 3, Maintenance Function. Column 3 lists the functions to be performed on the item listed in Column 2. (For detailed explanation of these functions, see paragraph B-2).

d. Column 4, Maintenance Category. Column 4 specifies, by the listing of a work time figure in the appropriate subcolumn(s), the category of maintenance authorized to perform the function listed in Column 3. This figure represents the active time required to perform that maintenance function at the indicated category of maintenance. The work time figure represents the average time required to restore an item (assembly, subassembly, component, or end item) to a serviceable condition under typical field operating conditions.

e. Column 5, Tools and Equipment. Column 5 specifies, by code, those common tool sets (not individual tools) and support equipment required to perform the designated function.

f. Column 6, Remarks. This column shall, when applicable, contain a letter code, in alphabetical order, which shall be keyed to the remarks contained in Section IV.

B-4. Explanation of Columns in Tool and Test Equipment Requirements, Section III.

a. Column 1, Reference Code. The tool and test equipment reference code correlates with a code used in the MAC, Section II, Column 5.

b. Column 2, Maintenance Category. The lowest category of maintenance authorized to use the tool. The "O" code corresponds to Aviation Unit Maintenance (AVUM), and the "F" code corresponds to

Aviation Intermediate Maintenance (AVIM).

- c. Column 3, Nomenclature. Name or identification of the tool.
- d. Column 4, National Stock Number. The National Stock Number of the tool.

B-5. Explanation of Columns in Remarks, Section IV.

- a. Column 1, Reference Code. The code recorded in Section II, Column 6.
- b. Column 2, Remarks. This column lists information pertinent to the maintenance function being performed as indicated in the MAC, Section II.

SECTION II. MAINTENANCE ALLOCATION CHART FOR HYDRAULIC KNEELING/ERECTING CART

(1) GROUP NUMBER	(2) COMPONENT/ASSEMBLY	(3) MAINTENANCE FUNCTION	(4) MAINTENANCE CATEGORY		(5) TOOLS AND EQUIPMENT	(6) REMARKS
			AVUM	AVIM		
00	Hydraulic Kneeling/Erecting Cart					
01	Wheel					
0101	Wheel	Inspect Service Replace	0.2 0.2 0.8		2	E
02	Frame/Cabinet Assembly					
0201	Control Panel Cover and Latch Assembly	Inspect Repair Replace	0.1 0.3	0.4	8,10 2	
0202	Cabinet Door	Inspect Repair Replace	0.1 0.2	0.3	8,10 2	
0203	Door Lock	Inspect Replace	0.2 0.6		2	E

SECTION II. MAINTENANCE ALLOCATION CHART FOR HYDRAULIC KNEELING/ERECTING CART (Continued)

(1) GROUP NUMBER	(2) COMPONENT/ASSEMBLY	(3) MAINTENANCE FUNCTION	(4) MAINTENANCE CATEGORY		(5) TOOLS AND EQUIPMENT	(6) REMARKS
			AVUM	AVIM		
03	Hydraulic System					
0301	Gear Pump	Inspect Replace	0.3 0.5		3	
0302	Pressure Gage	Inspect Calibrate* Replace	0.1 0.2	0.5	4	C,D
0303	Relief Valve	Inspect Adjust Repair Replace	0.1 0.3 0.2	0.5	1 7	
0304	Solenoid Valve	Inspect Repair Replace	0.2 0.5	1.0	6,7 6,7	
0305	Quick Disconnect	Inspect Replace	0.1 0.3		1	
0306	Needle Valve Knob	Inspect Replace	0.1 0.3		4	
0307	Needle Valve	Inspect Repair Replace	0.2 0.3	0.5	7	
0308	Check Valve	Inspect Repair Replace	0.2 0.4	0.5	7	
0309	Manifold Assy.	Inspect Replace	0.2	1.0	7	
0310	Filter	Inspect Service Replace Test	0.1 0.3 0.4 0.3		2	A B

*Calibration to be performed by the U.S. Army, Test, Measurement and Diagnostic Equipment, Support Group.

SECTION II. MAINTENANCE ALLOCATION CHART FOR HYDRAULIC KNEELING/ERECTING CART (Continued)

(1) GROUP NUMBER	(2) COMPONENT/ASSEMBLY	(3) MAINTENANCE FUNCTION	(4) MAINTENANCE CATEGORY		(5) TOOLS AND EQUIPMENT	(6) REMARKS
			AVUM	AVIM		
0311	Filler/ Breather and Special Adapter	Inspect Replace	0.1 0.3		3	
0312	Fluid Level Sight Glass	Inspect Replace	0.1 0.3		3	
0313	Suction Strainer	Inspect Clean Replace	0.3 0.2 0.4		1,2	A
0314	Reservoir Tank	Inspect Repair Replace	0.1 1.0	1.0	3,7	
0315	Hydraulic Piping	Inspect Repair Replace Test	0.3 0.8	1.0 0.5	3,7	B
04	Electrical System					
0401	DC Motor	Inspect Replace Repair	0.5 0.5	1.5	2 2,6	
0402	Flexible Coupling	Inspect Replace	0.5 0.6		1	
0403	Start Relay, Electromagnetic Interference Filter and Circuit Breaker	Inspect Replace	0.5 0.4		5	
0404	Indicator Light and Switches	Inspect Service Replace	0.2 0.3 0.5		5	
0405	Wiring and Cables	Inspect Service Repair Replace	0.3 0.3	0.8 0.8	5,6 5,6	

SECTION III TOOL AND TEST EQUIPMENT REQUIREMENTS

TOOL OR TEST EQUIPMENT REF CODE	MAINTENANCE CATEGORY	NOMENCLATURE	NATIONAL/NATO STOCK NUMBER	TOOL NUMBER
1	0	Tool Set, AVUM Set No. 2	4920-00-567-0476	SC4920-99-CL-A92
2	0	Tool Kit, Aircraft Mechanics General	5180-00-323-4692	SC5180-99-CL-A01
3	0	Tool Kit, Hydraulic	5180-00-323-4891	SC5180-97-CL-A03
4	0	Tool Kit, Instrument	5180-00-323-4913	SC5180-99-CL-A05
5	0	Tool Kit, Electrical	5180-00-323-4915	SC5180-99-CL-A06
6	F	Shop Set, AVIM Electrical/ Instrument	4920-00-165-1453	SC4920-99-CL-A80
7	F	Shop Set, AVIM Hydraulic	4920-00-165-1454	SC4920-99-CL-A81
8	F	Shop Set, AVIM Sheet Metal	4920-00-166-5505	SC4920-99-CL-A85
9	F	Shop Set, AVIM Tool Crib	4920-00-472-4183	SC4920-99-CL-A86
10	F	Shop Set, AVIM Welding	4920-00-163-5093	SC4920-99-CL-A88

SECTION IV. REMARKS

REFERENCE CODE	REMARKS
A	Clean and/or replace filter elements, filter, and strainer.
B	Operational test for leaks.
C	Calibrate in accordance with existing procedures given in TB 43-180.
D	Operational test can be performed with component installed on end item.
E	Clean and lubricate.

APPENDIX C

REPAIR PARTS AND SPECIAL TOOLS LIST

SECTION I. INTRODUCTION

C-1. Scope.

This Repair Parts and Special Tools List, (RPSTL) lists and authorizes spares and repair parts; special tools; special test, measurement, and diagnostic equipment (TMDE); and other special support equipment required for performance of Aviation Unit and Aviation Intermediate maintenance on the Hydraulic Kneeling/Erecting Cart, Part Number 10064-10. It authorizes the requisitioning, issue, and disposition of spares, repair parts, and special tools as indicated by the Source, Maintenance, and Recoverability (SMR) codes.

C-2. General.

In addition to Section I, Introduction, this RPSTL is divided into the following sections:

- a. **Section II. Repair Parts List.** A list of spares and repair parts authorized by this RPSTL for use in the performance of maintenance. The list also includes parts which must be removed for replacement of the authorized parts. Parts lists are composed of functional groups in ascending numerical sequence, with the parts in each group listed in ascending figure and item number sequence. Bulk materials are listed in item name sequence. Repair parts kits are listed in their own functional group within Section II. Items listed are shown on the associated illustration(s)/figure(s).
- b. **Section III. Special Tools List.** Not applicable.
- c. **Section IV. Cross-reference Indexes.** A list, in National Item Identification Number (NIIN) sequence, of all National Stock Number (NSN) items appearing in the RPSTL, followed by a list in alphanumeric sequence of all part numbers appearing in the RPSTL. NSN and part numbers are cross-referenced to each illustration figure and item number appearance. The figure and item number index lists figure and item numbers in alphanumeric sequence and cross-references NSN, CAGE code, and part numbers.

C-3. Explanation of Columns (Sections II and III).

- a. **ITEM NO. (Column (1)).** Indicates the number used to identify items called out in the illustration.
- b. **SMR CODE (Column (2)).** The Source, Maintenance, and Recoverability (SMR) code is a 5-position code containing supply/requisitioning information, maintenance category authorization

criteria, and disposition instruction, as shown in the following breakout:

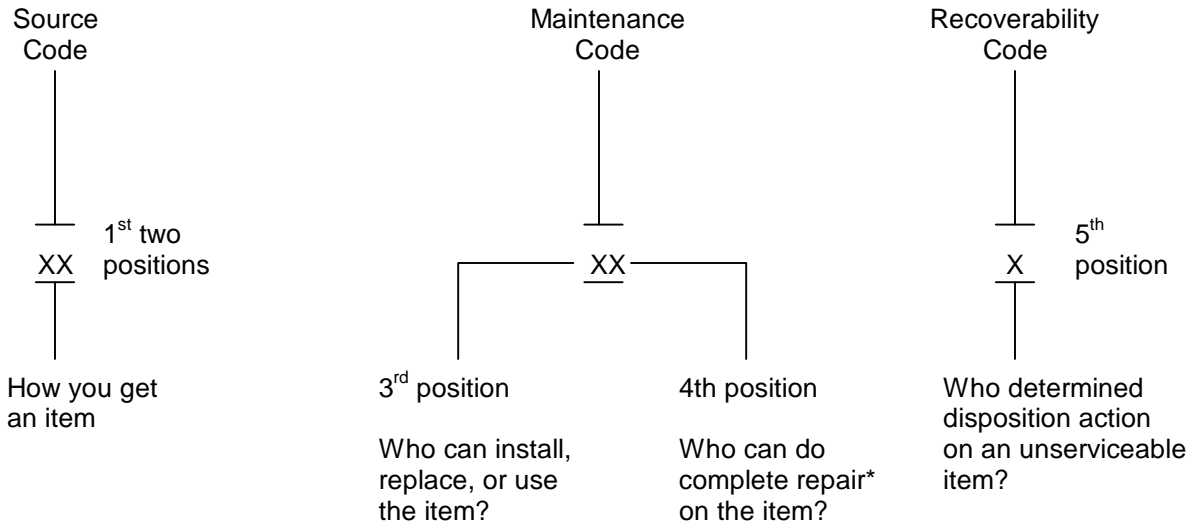

* Complete Repair: Maintenance capacity, capability, and authority to perform all corrective maintenance tasks of the "Repair" function in a use/user environment In order to restore serviceability to a failed item.

(1) Source Code. The source code tells you how to get an item needed for maintenance, repair, or overhaul of an end item/equipment. Explanations of source codes follows:

Code	Explanation
PA PB PC** PD PE PF PG	Stocked items; use the applicable NSN to request/requisition items with these source codes. They are authorized to the category indicated by the code entered in the 3rd position of the SMR code. ** NOTE: Items coded PC are subject to deterioration.
KD KF KB	Items with these codes are not to be requested/requisitioned individually. They are part of a kit which is authorized to the maintenance category indicated in the 3rd position of the SMR code. The complete kit must be requisitioned and applied.

Code	Explanation
MO-(Made at org/ AVUM Level)	Items with these codes are not to be requested/requisitioned individually. They must be made from bulk material which is identified by the part number in the DESCRIPTION AND USABLE ON CODE (UOC) column and listed in the Bulk Material group of the repair parts list in this RPSTL. If the item is authorized to you by the 3rd position code of the SMR code, but the source code indicates it is made at a higher level, order the item from the higher
MF-(Made at DS/ AVIM Level)	
MH-(Made at GS Level)	
ML-(Made at Spe- cialized Repair Act [SRA])	
MD-(Made at Depot level of maintenance.)	

Code	Explanation
AO-(Assembled by org/AVUM Level)	Items with these codes are not to be requested/requisitioned individually. The parts that make up the assembled item must be requisitioned or fabricated and assembled at the level of maintenance indicated by the source code. If the 3rd position code of the SMR code authorizes you to replace the item, but the source code indicates the item is assembled at a higher level, order the item from the higher level of maintenance.
AF-(Assembled by DS/AVIM Level)	
AH-(Assembled by GS Category)	
AL-(Assembled by SRA)	
AD-(Assembled by Depot)	

- XA- Do not requisition an "XA"-coded item. Order its next higher assembly. (Refer to the NOTE below.)
- XB- If an "XB" item is not available from salvage, order it using the CAGE code and part number given.
- XC- Installation drawing, diagram, instruction sheet, field service drawing, that is identified by manufacturer's part number.
- XD- Item is not stocked. Order an "XD"-coded item through normal supply channels using the CAGE code and part number given, if no NSN is available.

NOTE: Cannibalization or controlled exchange, when authorized, may be used as a source of supply for items with the above source codes, except for those source coded "XA" or restricted aircraft support items (refer to AR 750-1).

(2) Maintenance Code. Maintenance codes tell you the level(s) of maintenance authorized to USE and REPAIR support items. The maintenance codes are entered in the third and fourth positions of the SMR Code as follows:

- (a) The maintenance code entered in the third position tells you the lowest maintenance level authorized to remove, replace, and use an item. The maintenance code entered in the third position will indicate authorization to one of the following levels of

maintenance.

Code	Application/Explanation
C	-Crew or operator maintenance done within organizational or aviation unit maintenance.
O	-Organizational or aviation unit category can remove, replace, and use the item.
F	-Direct support or aviation intermediate level can remove, replace, and use the item.
H	-General support level can remove, replace, and use the item.
L	-Specialized repair activity can remove, replace, and use the item.
D	-Depot level can remove, replace, and use the item.

(b) The maintenance code entered in the fourth position tells whether or not the item is to be repaired and identifies the lowest maintenance level with the capability to do complete repair (i.e., perform all authorized repair functions). (NOTE: Some limited repair may be done on the item at a lower level of maintenance, if authorized by the Maintenance Allocation Chart (MAC) and SMR codes.) This position will contain one of the following maintenance codes.

Code	Application/Explanation
O	-Organizational or (aviation unit) is the lowest level that can do complete repair of the item.
F	-Direct support or aviation intermediate is the lowest level that can do complete repair of the item.
H	-General support is the lowest level that can do complete repair of the item.
L	-Specialized repair activity (designate the specialized repair activity) is the lowest level that can do complete repair of the item.
D	-Depot is the lowest level that can do complete repair of the item.
Z	-Nonrepairable. No repair is authorized.
B	-No repair is authorized. (No parts or special tools are authorized for the maintenance of a "B" coded item). However, the item may be reconditioned by adjusting, lubricating, etc., at the user level.

(3) Recoverability Code. Recoverability codes are assigned to items to indicate the disposition action on unserviceable items. The recoverability code is entered in the fifth position of the SMR Code as follows:

Recoverability Code	Application/Explanation
Z	-Nonrepairable item. When unserviceable, condemn and dispose of the item at the level of maintenance shown in 3rd position of SMR Code.
O	-Repairable item. When not economically repairable, condemn and dispose of the item at organizational or aviation unit level.
F	-Repairable item. When not economically repairable, condemn and dispose of the item at the direct support or aviation intermediate level.
H	-Repairable item. When not economically repairable, condemn and dispose of the item at the general support level.
D	-Repairable item. When beyond lower level repair capability, return to depot. Condemnation and disposal of item not authorized below depot level.
L	-Repairable item. Condemnation and disposal not authorized below specialized repair activity (SRA).
A	-Item requires special handling or condemnation procedures because of specific reasons (e.g., precious metal content, high dollar value, critical material, or hazardous material). Refer to appropriate manuals/directives for specific instructions.

c. CAGE CODE (Column (3)). The Commercial and Government Entity (CAGE) Code is a 5-digit numeric or alphanumeric code which is used to identify the manufacturer, distributor, or Government agency, etc., that supplies the item. The codes are contained in Cataloging Handbook H4/H8.

d. PART NUMBER (Column (4)). Indicates the primary number used by the manufacturer (individual, company, firm, corporation, or Government activity), which controls the design and characteristics of the item by means of its engineering drawings, specification standards, and inspection requirements to identify an item or range of items.

NOTE: When you use a NSN to requisition an item, the Item you receive may have a different part number from the part ordered.

e. DESCRIPTION AND USABLE ON CODE (UOC) (Column (5)). This column includes the following Information:

(1) The Federal item name and, when required, a minimum description to identify the item.

(2) The physical security classification of the item is indicated by the parenthetical entry (insert applicable physical security classification abbreviation, e.g., Phy Sec C1 (C) -Confidential, Phy Sec C1 (S) - Secret, Phy Sec C1 (T) - Top Secret).

(3) Items that are included in kits and sets are listed below the name of the kit or set.

(4) Spare/repair parts that make up an assembled item are listed immediately following the assembled item line entry.

(5) Part numbers for bulk materials are referenced in this column in the line item entry for the item to be manufactured/fabricated.

(6) When the item is not used with all serial numbers of the same model, the effective serial numbers are shown on the last line(s) of the description (before UOC).

(7) The usable on code, when applicable (see paragraph C-5, Special Information).

(8) In the Special Tools List section, the basis of issue (BOI) appears as the last line(s) in the entry for each special tool, special TMDE, and other special support equipment. When density of equipments supported exceeds density spread indicated in the basis of issue, the total authorization is increased proportionately.

(9) The statement "END OF FIGURE" appears Dust below the last item description in Column 5 for a given figure in both Section II and Section III.

f. QTY (Column (6)). The QTY (quantity per figure column) indicates the quantity of the item used in the breakout shown on the illustration figure, which is prepared for a functional group, subfunctional group, or an assembly. A "V" appearing in this column in lieu of a quantity indicates that the quantity is variable and the quantity may vary from application to application.

C-4. Explanation of Columns (Section IV).

a. NATIONAL STOCK NUMBER (NSN) INDEX.

(1) STOCK NUMBER column. This column lists the NSN by National Item Identification Number (NIIN) sequence. The NIIN

consists of the last nine digits

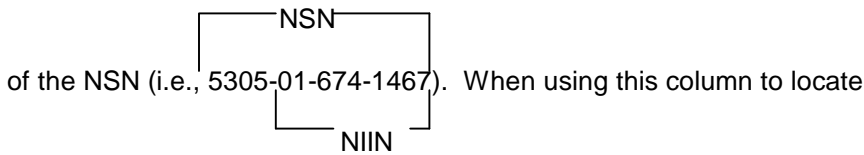

an item, ignore the first 4 digits of the NSN. However, the complete NSN should be used when ordering items by stock number.

(2) FIGURE column. This column lists the number of the figure where the item is identified/located. The figures are in numerical order in Section II and Section III.

(3) ITEM column. The item number identifies the item associated with the figure listed in the adjacent FIGURE column. This item is also identified by the NSN listed on the same line.

b. PART NUMBER INDEX. Part numbers in this index are listed by part number in ascending alphanumeric sequence (i.e., vertical arrangement of letter and number combination which places the first letter or digit of each group in order A through Z, followed by the numbers 0 through 9 and each following letter or digit in like order).

(1) CAGE CODE column. The Commercial and Government Entity (CAGE) code is a 5-digit numeric or alphanumeric code used to identify the manufacturer, distributor, or Government agency, etc., that supplies the item.

(2) PART NUMBER column. Indicates the primary number used by the manufacturer (individual, firm, corporation, or Government activity), which controls the design and characteristics of the item by means of its engineering drawings, specifications standards, and inspection requirements to identify an item or range of items.

(3) STOCK NUMBER column. This column lists the NSN for the associated part number and manufacturer identified in the PART NUMBER and CAGE CODE columns to the left.

(4) FIGURE column. This column lists the number of the figure where the Item is identified/located in Section II and III.

(5) ITEM column. The Item number is that number assigned to the item as it appears in the figure referenced in the adjacent figure number column.

c. FIGURE AND ITEM NUMBER INDEX.

(1) FIGURE column. This column lists the number of the figure where the item is identified/located in Section II and III.

(2) ITEM column. The item number is that number assigned to the item as it appears in the figure referenced in the adjacent figure number column.

(3) STOCK NUMBER column. This column lists the NSN for the item.

(4) CAGE CODE column. The Commercial and Government Entity (CAGE) Code is a 5-digit numeric or alphanumeric code used to identify the manufacturer, distributor, or Government agency, etc., that supplies the item.

(5) PART NUMBER column. Indicates the primary number used by the manufacturer (individual, firm, corporation, or Government activity), which controls the design and characteristics of the item by means of its engineering drawings, specifications standards, and inspection requirements to identify an item or range of items.

C-5. Special Information. Use the following subparagraphs as applicable:

a. USABLE ON CODE. The usable on code appears in the lower left corner of the Description column heading. Usable on codes are shown as "UOC:..." in the Description Column (justified left) on the first line applicable item description/nomenclature. Uncoded items are applicable to all models. Identification of the usable on codes used in the RPSTL are:

Code	Used On
Not Applicable	

b. FABRICATION INSTRUCTIONS. Bulk materials required to manufacture items are listed in the Bulk Material Functional Group of this RPSTL. Part numbers for bulk materials are also referenced in the description column of the line entry for the item to be manufactured/fabricated. Detailed fabrication instructions for items source codes to be manufactured or fabricated are not applicable.

c. ASSEMBLY INSTRUCTION. Detailed assembly instructions for items source coded to be assembled from component spare/repair parts are not applicable. Items that make up the assembly are listed immediately following the assembly item entry or reference is made to an applicable figure.

d. KITS. Line item entries for repair parts kits appear in a group in Section II (Not Applicable).

e. INDEX NUMBERS. Items which have the word BULK in the figure column will have an index number shown in the item number column. This index number is a cross-reference between the National Stock Number/Part Number Index and the bulk material list in Section II.

- f. ASSOCIATED PUBLICATIONS. Not applicable.
- g. ILLUSTRATIONS - LISTING. Not applicable.

C-6. How to Locate Repair Parts.

a. WHEN NATIONAL STOCK NUMBER OR PART NUMBER IS NOT KNOWN:

(1) First. Using the table of contents, determine the assembly group or subassembly group to which the item belongs. This is necessary since figures are prepared for assembly groups and subassembly groups, and listings are divided into the same groups.

(2) Second. Find the figure covering the assembly group or subassembly group to which the item belongs.

(3) Third. Identify the item on the figure and use the Figure and Item Number Index to find the NSN.

b. WHEN NATIONAL STOCK NUMBER OR PART NUMBER IS KNOWN:

(1) First. Using the National Stock Number or the Part Number Index, find the pertinent National Stock Number or Part Number. The NSN Index is In National Item Identification Number (NIIN) sequence (see C-4.a(1)). The part numbers in the Part Number Index are listed in ascending alphanumeric sequence (see C-4.b). Both indexes cross-reference you to the illustration/figure and item number of the item you are looking for.

(2) Second. Turn to the figure and item number, verify that the item is the one you're looking for, then locate the item number in the repair parts list for the figure.

C-7. Abbreviations. All are applicable to RPSTL and are listed in MIL-STD-12.

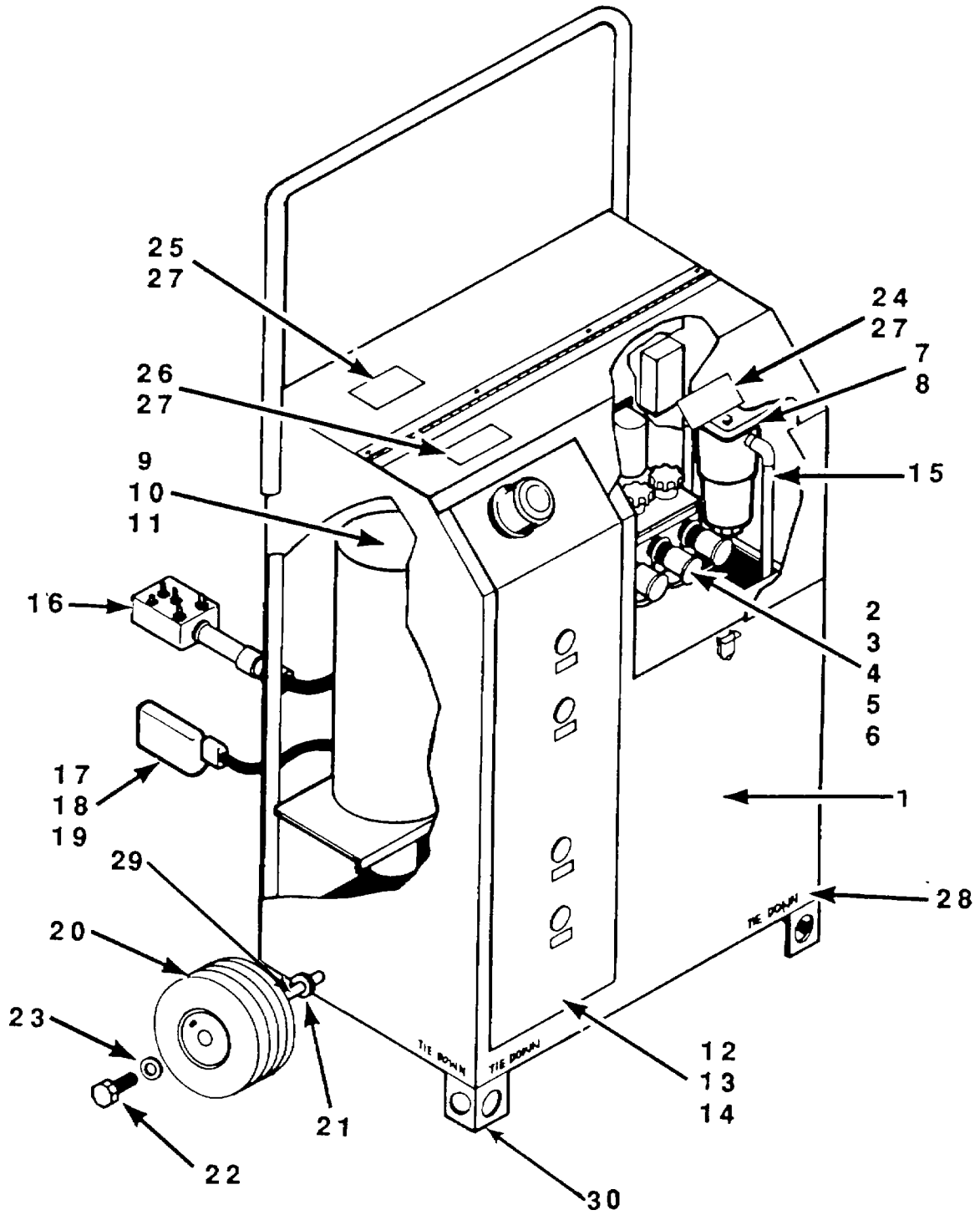

Figure 1. Hydraulic Kneeling/Erecting Cart

SECTION II. REPAIR PARTS AND SPECIAL TOOLS LIST

(1) ITEM NO.	(2) SMR CODE	(3) CAGE CODE	(4) PART NUMBER	(5) DESCRIPTION AND USABLE ON CODE (UOC)	(6) QTY
				GROUP 00: HYDRAULIC KNEEL- ING/ERECTING CART GROUP 01: WHEEL GROUP 0101: WHEEL GROUP 0310: FILTER FIGURE 1. HYDRAULIC KNEEL- ING/ERECTING CART	
	PAOFF	60984	10064-10	HYDRAULIC KNEELING/ERECT- ING CART	
1	PAFFF	60984	20080-10	FRAME/CABINET ASSY (SEEFIGURE 2 FOR BREAKDOWN)	1
2	PAFFF	60984	20081-10	.MANIFOLD ASSY (SEE FIGURE 3 FOR BREAKDOWN)	1
3	PAOZZ	96906	MS51967-2	.NUT, PLAIN, HEX.....	4
4	PAOZZ	96906	MS35338-44	.WASHER, LOCK.....	4
5	PAOZZ	96906	MS27183-10	.WASHER, FLAT.....	4
6	XDOZZ	60984	41023-01	.STANDOFF	4
7	PAOOO	59793	DFBN/HC30G3B1. 0/12	.FILTER, PRESS, HYD.....	1
	PAOZZ	59793	0060D010BN/HC	..ELEMENT	V
8	PAOZZ	60984	40179-1	.BOLT, WASHER HD, HEX.....	4
9	PAOFF	60984	20078-10	.MOTOR AND PUMP ASSY (SEE FIGURE 4 FOR BREAKDOWN)	1
10	PAOZZ	96906	MS90726-3	.SCREW, HEX HD.....	4
11	PAOZZ	96906	MS35338-46	.WASHER, LOCK.....	4
12	PBOFF	60984	20079-10	.RESERVOIR ASSY (SEE FIGURE..... 5 FOR BREAKDOWN)	1
13	PAOZZ	96906	MS90725-6	.SCREW, HEX HD	4
14	PAOZZ	96906	MS51943-31	.NUT, NYLOCK.....	4
15	PAFFF	60984	20082-10	.HYDRAULIC PIPING ASSY (SEE..... FIGURE 6 FOR BREAKDOWN)	1
16	PAOOO	60984	20083-10	.CONTROL BOX ASSY (SEE FIGURE 7 FOR BREAKDOWN)	1
17	PAFFF	60984	20084-10	.ELECTRICAL COMPONENTS AND WIRING ASSY (SEE FIGURE 8 FOR BREAKDOWN)	1
18	PAOZZ	60984	40179-1	.BOLT, WASHER HD.....	2
19	PAOZZ	96906	MS21044N3	.NUT, NYLOCK.....	2
20	XDOZZ	39428	8352T28	.WHEEL, SEMI-PNEUMATIC	2
21	PAOZZ	96906	MS27183-23	.WASHER, FLAT.....	2
22	PAOZZ	96906	MS90725-55	.SCREW, HEX HD	2
23	PAOZZ	96906	MS27183-14	.WASHER, FLAT.....	2
24	PAOZZ	60984	41018-01	.NPL, IDENT	1
25	PAOZZ	60984	41019-03	.NPL, WARNING	1

SECTION II. REPAIR PARTS AND SPECIAL TOOLS LIST

(1) ITEM NO.	(2) SMR CODE	(3) CAGE CODE	(4) PART NUMBER	(5) DESCRIPTION AND USABLE ON CODE (UOC)	(6) QTY
26	PAOZZ	60984	41019-01	.NPL, HYDRAULIC FILL	1
27	PAOZZ	96906	MS21318-19	.SCREW, DRIVE	12
28	PAOZZ	60984	41024-01	.STENCIL, TIE-DOWN	1
29	PAFZZ	60984	41003-11	.AXLE (WELDED).....	REF
20	PAOZZ	39428	93085K18	.RUBBER STRIP, SELF ADHESIVE	V
END OF FIGURE					

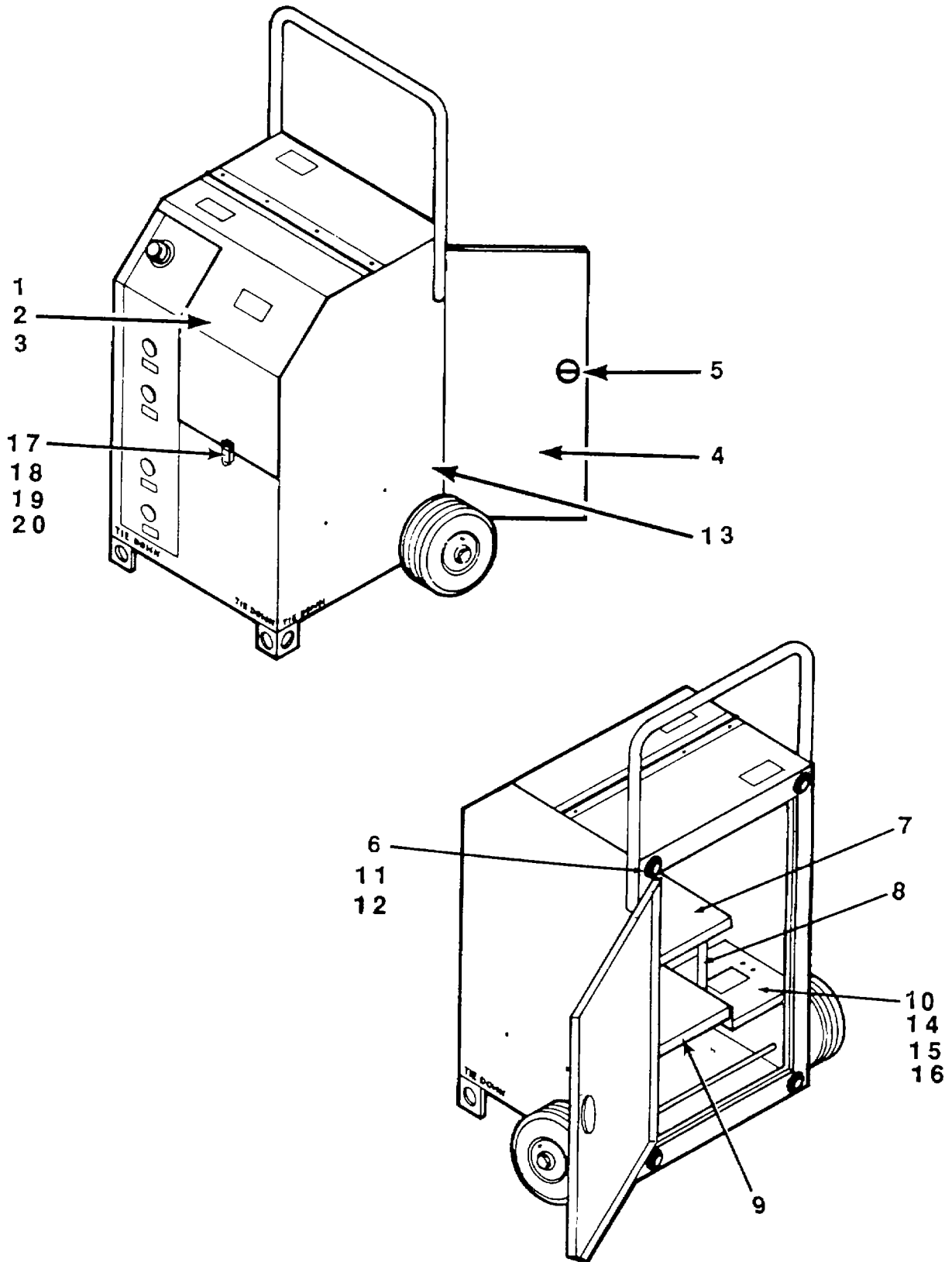

Figure 2. Frame/Cabinet Assembly

SECTION II. REPAIR PARTS AND SPECIAL TOOLS LIST

(1) ITEM NO.	(2) SMR CODE	(3) CAGE CODE	(4) PART NUMBER	(5) DESCRIPTION AND USABLE ON CODE (UOC)	(6) QTY
				GROUP 02: FRAME/CABINET ASSEMBLY GROUP 0201: CONTROL PANEL COVER AND LATCH ASSEMBLY GROUP 0202: CABINET DOOR GROUP 0203: DOOR LOCK FIGURE 2: FRAME/CABINET ASSEMBLY	
	PAFFF	60984	20080-10	FRAME/CABINET ASSY (SEE FIGURE 1 FOR NHA)	
1	XDOZZ	60984	41010-01	.COVER, CONTROL PANEL.....	1
2	PAOZZ	60984	40179-1	.BOLT, WASHER HD.....	4
3	PAOZZ	96906	MS21044N3	.NUT, NYLOCK	4
4	XDOFF	60984	41009-01	.DOOR, CABINET	1
5	PAFZZ	94222	01-13-45	.LOCK, DOOR	1
6	PAFZZ	39428	9540K28	.BUMPER, RUBBER	4
7	XDOZZ	60984	41003-33	.TRAY, UPPER (WELDED)	REF
8	XDOZZ	60984	41003-37	.SUPPORT, TRAY (WELDED)	REF
9	XDOZZ	60984	41003-35	.TRAY, LOWER (WELDED)	REF
10	XDOZZ	60984	41013-01	.BRACKET, MOTOR	1
11	PAFZZ	60984	40179-1	.BOLT, WASHER HD.....	4
12	PAFZZ	96906	MS21044N3	.NUT, NYLOCK	4
13	XAFZZ	60984	41003-01	.FRAME/CABINET (WELDED)	1
14	PAOZZ	96906	MS90725-6	.SCREW, CAP.....	4
15	PAOZZ	96906	MS35338-44	.WASHER, LOCK.....	4
16	PAOZZ	96906	MS51967-2	.NUT, PLAIN	4
17	PAOZZ	98003	HC83314-42- LALB-SS	.CATCH.....	1
18	PAOZZ	96906	MS35206-230	.SCREW, MACH, PNH.....	2
19	PAOZZ	96906	MS27183-5	.WASHER, FLAT.....	2
20	PAOZZ	96906	MS21044N06	.NUT, SELF-LOCK	2
				END OF FIGURE	

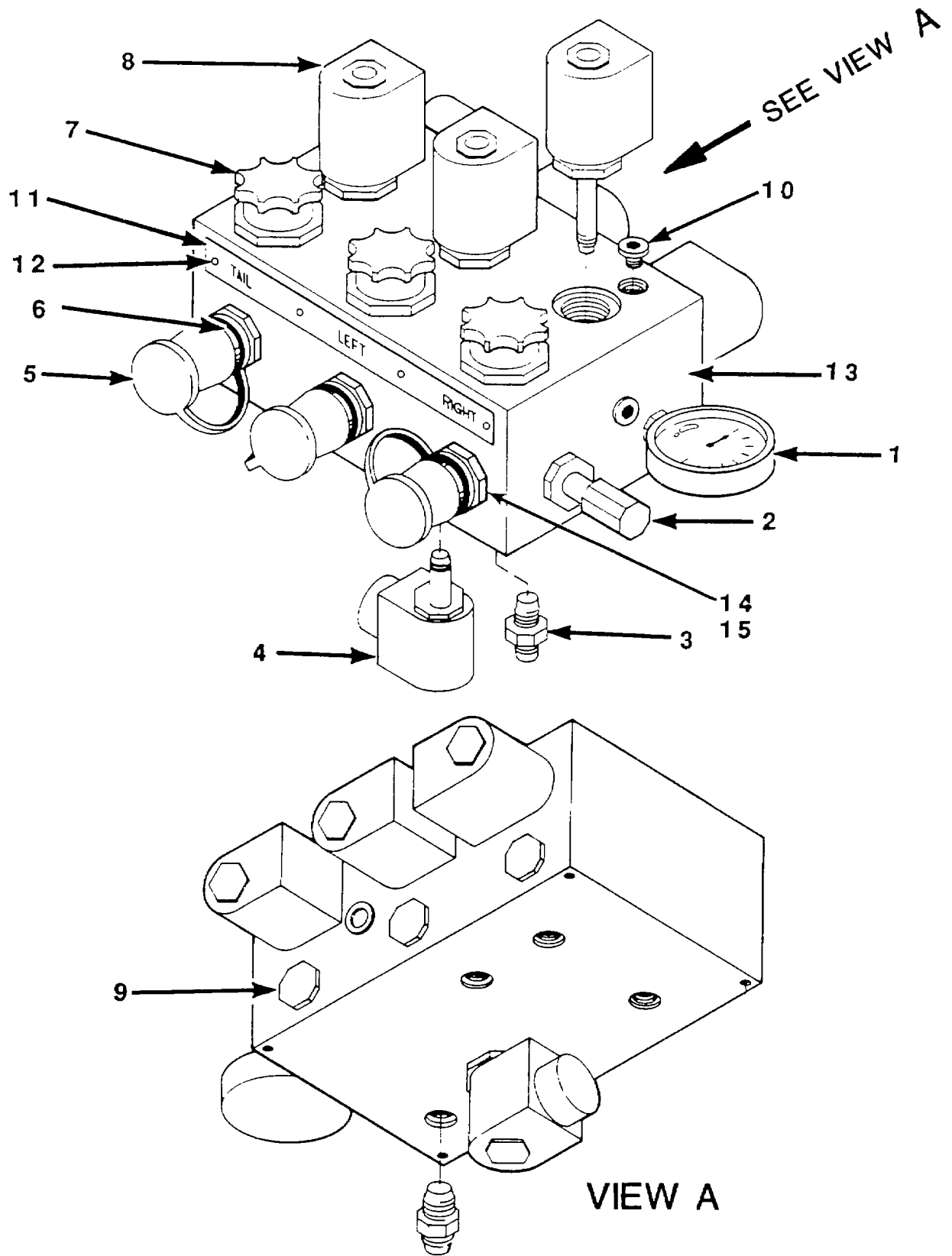

Figure 3. Manifold Assembly

SECTION II. REPAIR PARTS AND SPECIAL TOOLS LIST

(1) ITEM NO.	(2) SMR CODE	(3) CAGE CODE	(4) PART NUMBER	(5) DESCRIPTION AND USABLE ON CODE (UOC)	(6) QTY
				GROUP 03: HYDRAULIC SYSTEM GROUP 0302: PRESSURE GAGE GROUP 0303: RELIEF VALVE GROUP 0304: SOLENOID VALVE GROUP 0305: QUICK DIS- CONNECT GROUP 0306: NEEDLE VALVE KNOB GROUP 0307: NEEDLE VALVE GROUP 0308: CHECK VALVE GROUP 0309: MANIFOLD FIGURE 3. MANIFOLD ASSEMBLY	
1	PAFFF	60984	20081-10	MANIFOLD ASSY (SEE FIGURE 1 FOR NHA)	
2	PAFZZ	62091	25.300-5000PSI -1/4NPT	.GAGE, PRESSURE	1
2	PAOFF	54846	RV6-10-C-0- 100-3000 PSI	.VALVE, RELIEF, SPECIAL	1
	PAFZZ	96906	MS28778-10	..O' RING (REPLACEMENT)	1
	PAFZZ	96906	MS28775-014	..O' RING (REPLACEMENT)	1
	PAFZZ	96906	MS28774-014	..BACK-UP WASHER	1
3	PAFZZ	96906	MS51525B6	(REPLACEMENT) .CONNECTOR, STR THD	4
4	PAFFF	54846	SV4-10-0-0- 24DW	.VALVE, SOLENOID.....	1
	PAFZZ	96906	MS28778-10	..O' RING (REPLACEMENT)	1
	PAFZZ	96906	MS28775-014	..O' RING (REPLACEMENT)	1
	PAFZZ	96906	MS28774-014	..BACK-UP WASHER.....	2
5	PAOZZ	78357	PDC-12	(REPLACEMENT) .CAP, DUST	3
6	PAFFF	00624	3302-4	.QUICK DISCONNECT	3
7	PAOFF	54846	NV1-10-K-0	.VALVE, NEEDLE.....	3
	PAFZZ	96906	MS28778-10	..O' RING (REPLACEMENT)	1
	PAFZZ	96906	MS28775-014	..O' RING (REPLACEMENT)	1
	PAFZZ	96906	MS28774-014	..BACK-UP WASHER.....	2
8	PAFFF	54846	SV3-10-C-0- 24DW	(REPLACEMENT) .VALVE, SOLENOID.....	6
	PAFZZ	96906	MS28778-10	..O' RING (REPLACEMENT)	1
	PAFZZ	96906	MS28775-014	..O' RING (REPLACEMENT)	1
	PAFZZ	96906	MS28774-014	..BACK-UP WASHER.....	1
9	PAFFF	54846	CV1-10-B-0-5	(REPLACEMENT) .VALVE, CHECK.....	3
	PAFZZ	96906	MS28778-10	..O' RING (REPLACEMENT)	1
	PAFZZ	96906	MS28775-014	..O' RING (REPLACEMENT)	1

SECTION II. REPAIR PARTS AND SPECIAL TOOLS LIST

(1) ITEM NO.	(2) SMR CODE	(3) CAGE CODE	(4) PART NUMBER	(5) DESCRIPTION AND USABLE ON CODE (UOC)	(6) QTY
	PAFZZ	96906	MS28774-014	..BACK-UP WASHER..... (REPLACEMENT)	1
10	PAFZZ	30780	4HP50N-S	.PLUG, HOLLOW, HEX.....	5
11	XDFZZ	60984	41019-05	.NPL, TAIL-LEFT-RIGHT	1
12	PAFZZ	96906	MS21318-19	.SCREW, DRIVE	4
13	XAFZZ	60984	50167-01	.MANIFOLD	1
14	PAFZZ	39428	91079A032	.NUT, HEX JAM.....	3
15	PAFZZ	96906	MS29512-4	.'O' RING GASKET.....	3
END OF FIGURE					

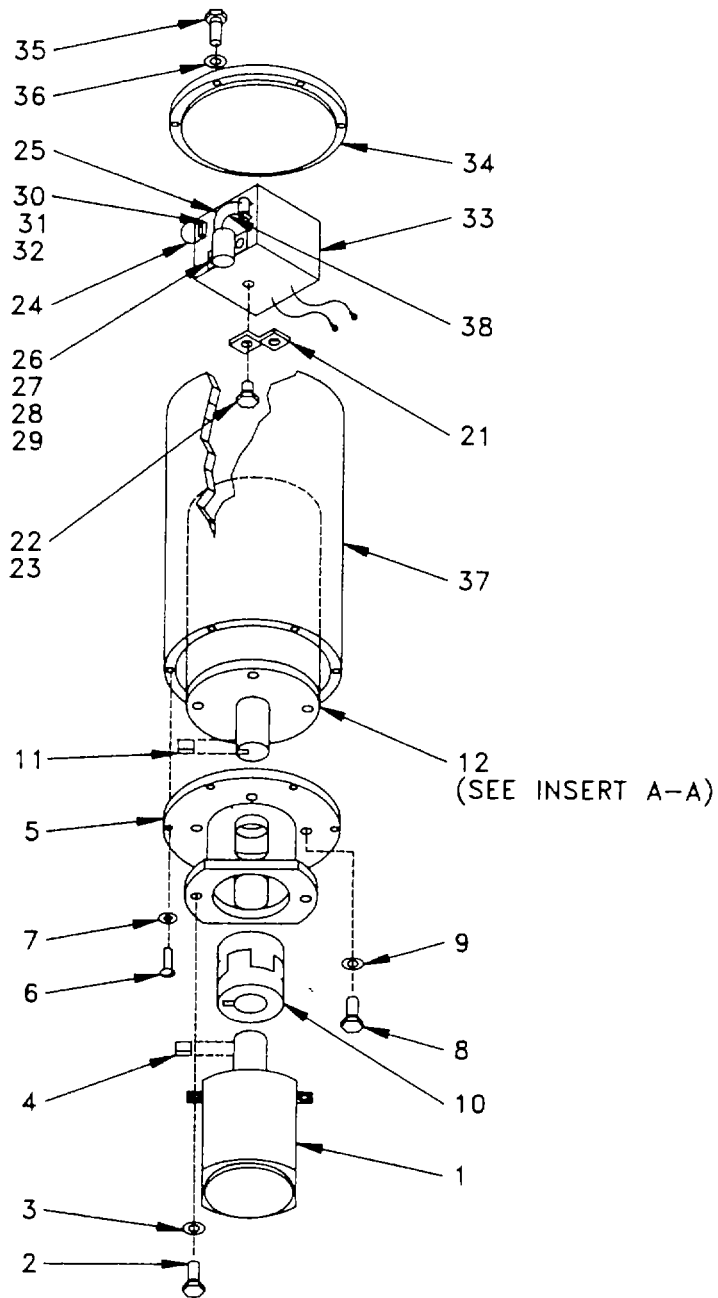

Figure 4. Motor And Pump Assembly (Page 1 Of 2)

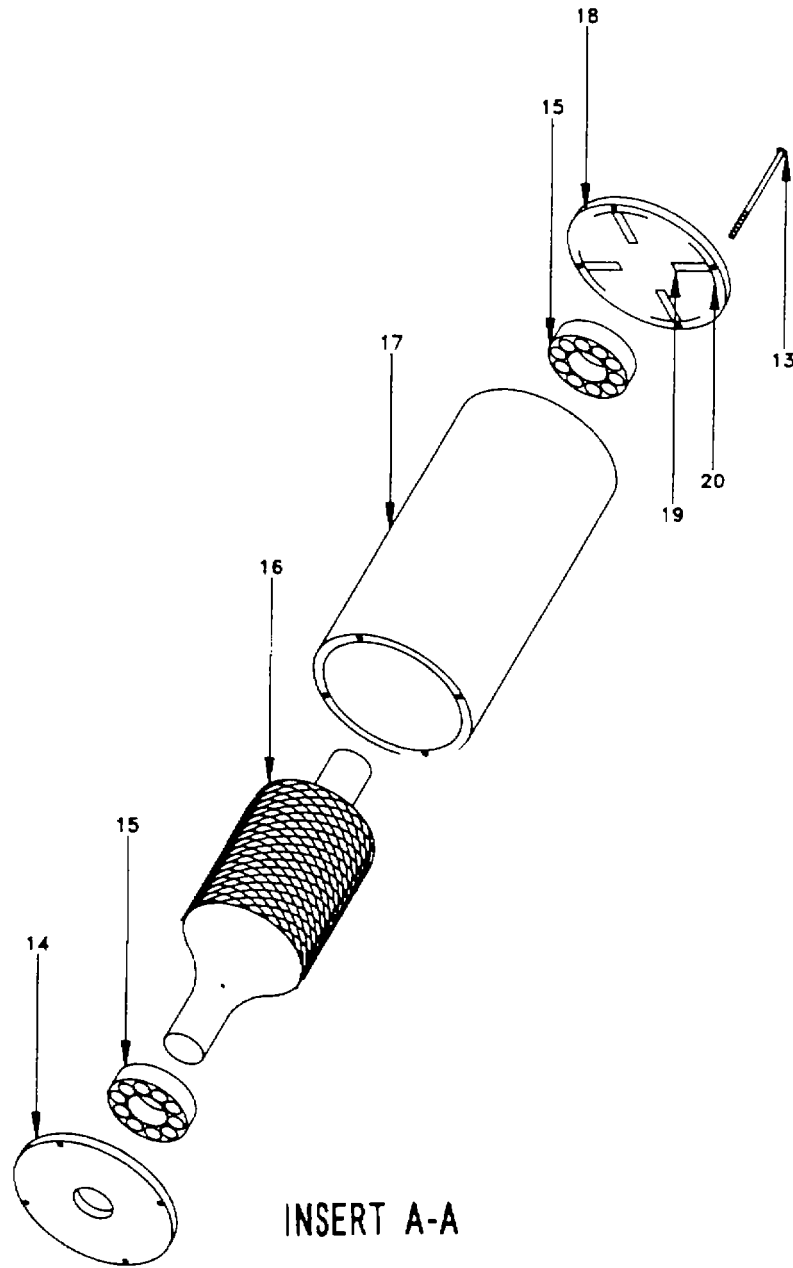

Figure 4. Motor And Pump Assembly (Page 2 Of 2)

SECTION II. REPAIR PARTS AND SPECIAL TOOLS LIST

(1) ITEM NO.	(2) SMR CODE	(3) CAGE CODE	(4) PART NUMBER	(5) DESCRIPTION AND USABLE ON CODE (UOC)	(6) QTY
				GROUP 04: ELECTRICAL SYSTEM GROUP 0301: GEAR PUMP GROUP 0401: DC MOTOR GROUP 0402: FLEXIBLE COUPLING GROUP 0403: START RELAY AND CIRCUIT BREAKER FIGURE 4. MOTOR AND PUMP ASSEMBLY	
	PAOFF	60984	20078-10	MOTOR AND PUMP ASSY (SEE FIGURE 1 FOR NHA)	
1	PAFFF	14140	TFP1002.6DCI06	..PUMP, GEAR HYD.....	1
2	PAOZZ	96906	MS90725-58	..SCREW, CAP, HEX.....	2
3	PAOZZ	96906	MS35338-46	..WASHER, LOCK.....	2
4	PAOZZ	60984	41007-01	..KEY (PUMP SHAFT).....	1
5	XDOFF	60984	41002-01	..ADAPTER, MOTOR/PUMP.....	1
6	PAOZZ	96906	MS35206-247	..SCREW, MACH, PNH.....	6
7	PAOZZ	96906	MS35338-42	..WASHER, LOCK.....	6
8	PAOZZ	96906	MS90725-10	..SCREW, CAP, HEX HD.....	4
9	PAOZZ	96906	MS35338-44	..WASHER, LOCK.....	4
10	PAOZZ	75665	L-075	..COUPLING ASSY., FLEX.....	1
	PAOZZ	75665		..COUPLING HALF, PUMP SHAFT 1/2 IN. BORE, W/1/8 IN. KEY & SET SCREW.....	1
	PAOZZ	75665		..COUPLING HALF, MOTOR SHAFT 5/8 IN. BORE W/3/16 KEY & SET SCREW.....	1
11	PAOZZ	75665		..SPIDER (L075SOX).....	1
12	PAFFF	60984	41007-03	..KEY, MOTOR SHAFT.....	1
			4BD-X588	..ELEC. MOTOR ASSY., 24VDC (SEE INSERT A-A).....	1
13	PAFZZ	60984	1BLT-01819	..BOLT, MOTOR.....	2
14	XDFZZ	60984	1DEC-00500	..CAP, DRIVE END.....	1
15	PAFZZ	60984	1BRG-00818	..BEARING.....	2
16	PAFFF	60984	1ARM-X588	..ARMATURE ASSY.....	1
17	PAFZZ	60984	1CSA-X588	..MOTOR CASE, W/MAGNETS.....	1
18	PAFZZ	60984	1BCA-01071	..CAP ASSY., BRUSH.....	1
19	PAFZZ	60984	1BRU-00040	... BRUSH.....	4
20	PAFZZ	60984	1NEG-00149	... SPRING, BRUSH.....	4
21	XDOZZ	60984	41039-01	..BRACKET.....	1
22	PAOZZ	96906	MS35207-263	..SCREW, MACH, PNH.....	1
23	PAOZZ	96906	MS21044N3	..NUT, SELF-LOCKING.....	1
24	XDOZZ	60984	60062-01	..WIRE (CB TO RELAY).....	1
25	XDOZZ	60984	60062-03	..WIRE (RELAY TO ISOLATION TERMINAL).....	1

SECTION II. REPAIR PARTS AND SPECIAL TOOLS LIST

(1) ITEM NO.	(2) SMR CODE	(3) CAGE CODE	(4) PART NUMBER	(5) DESCRIPTION AND USABLE ON CODE (UOC)	(6) QTY
26	PAOZZ	28891	124-903	.RELAY, START	1
27	PAOZZ	96906	MS35207-263	.SCREW, MACH, PNH.....	2
28	PAOZZ	96906	MS27183-8	.WASHER, FLAT.....	2
29	PAOZZ	96906	MS21044N3	.NUT, SELF-LOCKING.....	2
30	PAOZZ	13445	30055-10	.CIRCUIT BREAKER.....	1
31	PAOZZ	96906	MS35207-263	.SCREW, MACH, PNH.....	2
32	PAOZZ	96906	MS21044N3	.NUT, SELF-LOCKING.....	2
33	PAFFF	60984	41037-01	.ELECTRO-MAGNETIC INTER- FERENCE FILTER.....	1
34	XDOZZ	60984	41006-01	.PLATE, CASE, REAR	1
35	PAOZZ	96906	MS35206-247	.SCREW, MACH, PNH.....	6
36	PAOZZ	96906	MS35338-42	.WASHER, LOCK.....	6
37	XDOZZ	60984	41005-01	.CASE, OUTER	1
38	XDOZZ	60984	60062-05	.WIRE (RELAY TO ISOLATION TERMINAL)	1
END OF FIGURE					

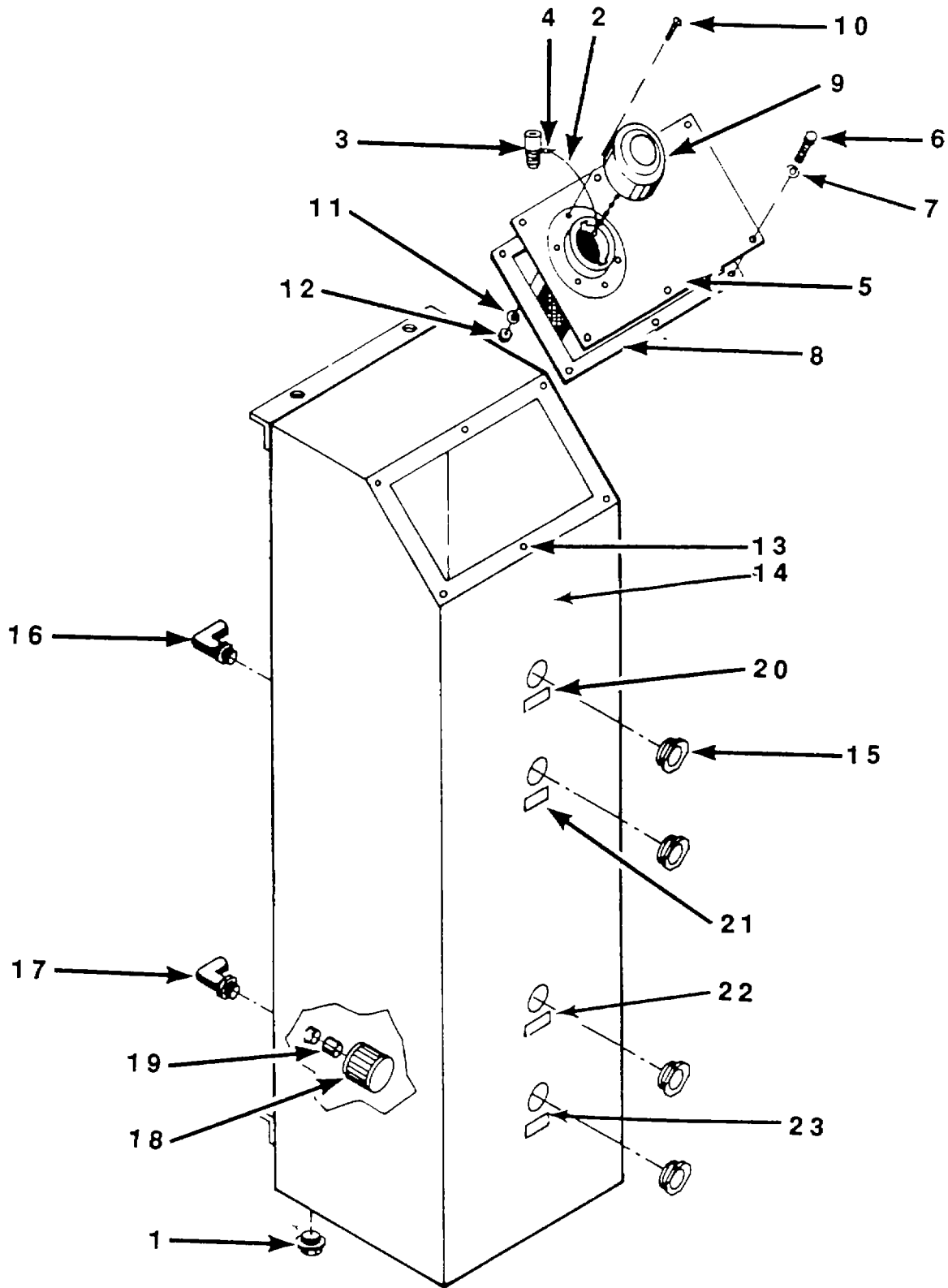

Figure 5. Reservoir Assembly

SECTION II. REPAIR PARTS AND SPECIAL TOOLS LIST

(1) ITEM NO.	(2) SMR CODE	(3) CAGE CODE	(4) PART NUMBER	(5) DESCRIPTION AND USABLE ON CODE (UOC)	(6) QTY
				GROUP 03: HYDRAULIC SYSTEM GROUP 0311: FILLER/BREATHER AND SPECIAL ADAPTER GROUP 0312: FLUID LEVEL SIGHT GLASS GROUP 0313: SUCTION STRAINER GROUP 0314: RESERVOIR TANK FIGURE 5. RESERVOIR ASSEMBLY	
	PBOFF	60984	20079-10	RESERVOIR ASSY (SEE FIGURE 1 FOR NHA)	
1	PAOZZ	39428	4638K514	.PLUG, DRAIN.....	1
2	PAOZZ	60984	20079-05	.LANYARD (9 IN/MIL-W-83420D WIRE).....	1
3	PBOZZ	60984	50168-01	.ADAPTER, SPECIAL.....	1
4	PAOZZ	96906	MS51844-22	.CRIMP FASTENER.....	2
5	XDOZZ	60984	20079-01	.COVER PLATE, RESERVOIR.....	1
6	PAOZZ	39428	91773A827	.SCREW, MACH, RDH.....	6
7	PAOZZ	39428	92146A011	.WASHER, LOCK.....	6
8	PAOZZ	60984	20079-03	.GASKET, RSVR (BUNA N 1/16 THICK).....	1
9	PAOZZ	70587	A-100-W	.FILLER/BREATHER.....	1
10	PAOZZ	39428	91773A827	.SCREW, MACH, RDH.....	6
11	PAOZZ	39428	92146A011	.WASHER, LOCK.....	6
12	PAOZZ	39428	91842A011	.NUT, BREATHER.....	6
13	PAOZZ	84256	AT502-S2-1032	.NUTSERT.....	6
14	PBFFF	60984	41001-01	.TANK, RESERVOIR.....	6
15	PAOZZ	24346	LSP101-08-01	.SIGHT GLASS, FLUID LEVEL.....	4
16	PAOZZ	96906	MS51504B6-8	.ELBOW, MALE PIPE.....	1
17	PAOZZ	96906	MS51504B8-8	.ELBOW, MALE NPT.....	1
18	PAOZZ	OG8T2	1A761	.STRAINER, SUCTION.....	1
19	PAOZZ	39428	4549K571	.NIPPLE, PIPE.....	1
20	PAFZZ	60984	41019-15	.NPL, REMOVE FLUID.....	1
21	PAFZZ	60984	41019-07	.NPL, FULL LEVEL.....	1
22	PAFZZ	60984	41019-13	.NPL, OPNL LEVEL.....	1
23	PAFZZ	60984	41019-11	.NPL, LOW LEVEL.....	1
				END OF FIGURE	

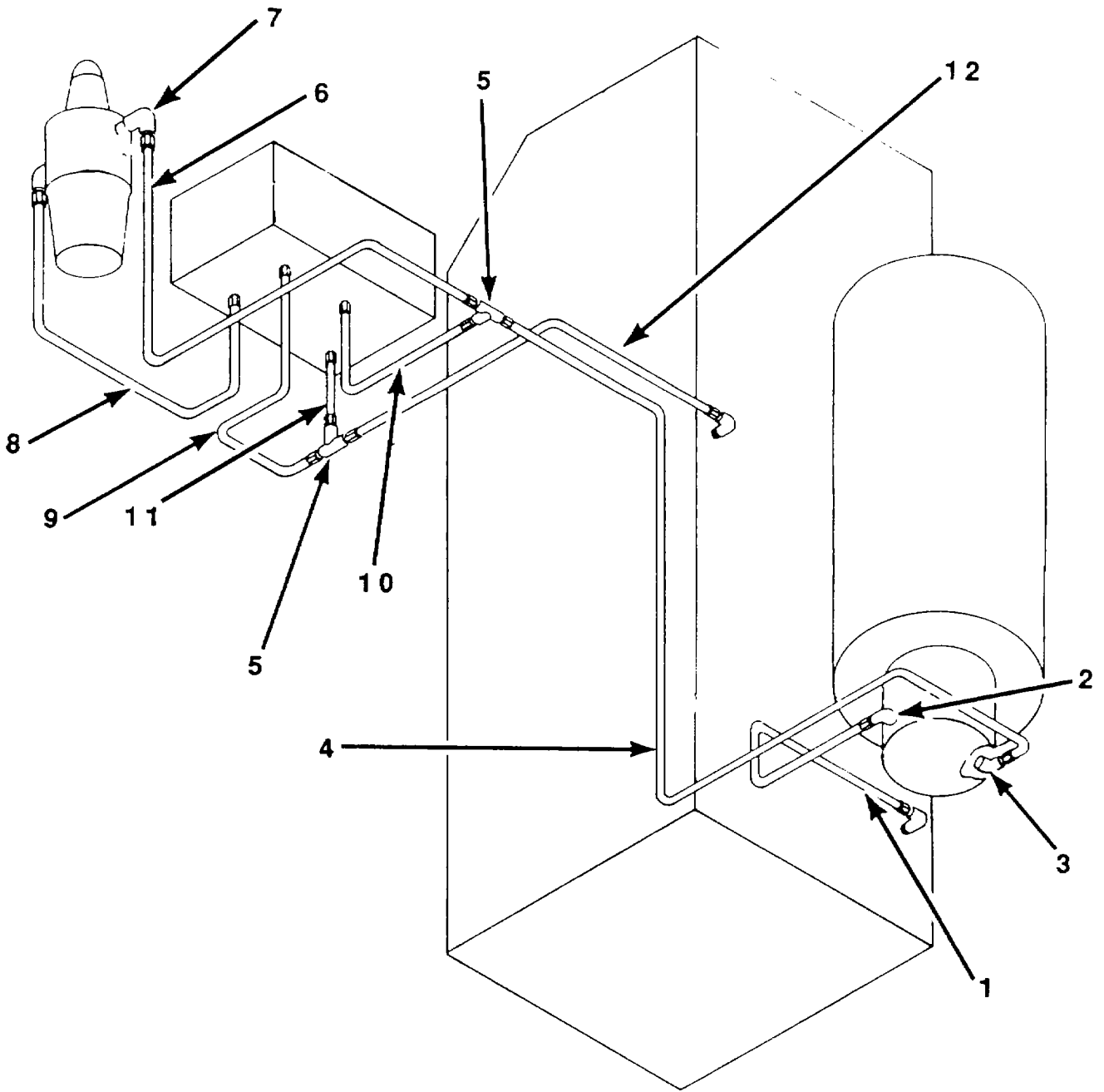

Figure 6. Hydraulic Piping Assembly

SECTION II. REPAIR PARTS AND SPECIAL TOOLS LIST

(1) ITEM NO.	(2) SMR CODE	(3) CAGE CODE	(4) PART NUMBER	(5) DESCRIPTION AND USABLE ON CODE (UOC)	(6) QTY
				GROUP 03: HYDRAULIC SYSTEM GROUP 0315: HYDRAULIC PIPING	
				FIGURE 6. HYDRAULIC PIPING ASSEMBLY	
	PAFFF	60984	20082-10	HYDRAULIC PIPING ASSEMBLY (SEE FIGURE 1 FOR NHA)	
1	MFFZZ	60984	50169-01	.TUBE ASSY, RESERVOIR - PUMP	1
				INLET	
2	PAFZZ	96906	MS51527B8	.ELBOW, STR THD	1
3	PAFZZ	96906	MS51527B6	.ELBOW, STR THD	1
4	MFFZZ	60984	50170-01	.TUBE ASSY, PUMP OUT-TEE	1
5	PAFZZ	96906	MS51510B6	.TEE, UNION	2
6	MFFZZ	60984	50171-01	.TUBE ASSY, TEE-FILTER INLET	1
7	PAFZZ	96906	MS51527B6-8	.ELBOW, STR THD	2
8	MFFZZ	60984	50172-01	.TUBE ASSY, FILTER OUT-.....	1
				MANIFOLD	
9	MFFZZ	60984	50173-01	.TUBE ASSY, MANIFOLD-TEE	1
10	MFFZZ	60984	50174-01	.TUBE ASSY, TEE-MANIFOLD	1
11	MFFZZ	60984	50175-01	.TUBE ASSY, MANIFOLD-TEE	1
12	MFFZZ	60984	50176-01	.TUBE ASSY, TEE-RESERVOIR.....	1
				END OF FIGURE	

SECTION II. REPAIR PARTS AND SPECIAL TOOLS LIST

(1) ITEM NO.	(2) SMR CODE	(3) CAGE CODE	(4) PART NUMBER	(5) DESCRIPTION AND USABLE ON CODE (UOC)	(6) QTY
				GROUP 04: ELECTRICAL SYSTEM GROUP 0404: INDICATOR LIGHT AND SWITCHES	
				FIGURE 7. CONTROL BOX ASSEMBLY	
	PAOOO	60984	20083-10	CONTROL BOX ASSY (SEE FIGURE 1 FOR NHA)	
1	PAOZZ	96906	MS51959-30	.SCREW (6-32 X 1/2).....	4
2	PAOZZ	68592	8510K1	.SWITCH, TOGGLE, START	1
3	PAOZZ	68592	8511K2	.SWITCH, TOGGLE, CONTROL	3
4	PAOZZ	95263	L59D-R24-W	.LIGHT, INDICATOR, POWER	1
5	XDOZZ	60984	41016-01	.HOOK	1
6	PAOZZ	39428	90283A110	.SCREW, MACH, PNH.....	2
7	PAOZZ	39428	90675A005	.LOCKNUT	2
8	PAOZZ	56501	143	.LOCKNUT	2
9	PAOZZ	56501	5304	.SEAL RING.....	1
10	PBOZZ	60984	41026-01	.CONDUIT, AL	1
11	PBOZZ	60984	41025-01	.COUPLING,PIPE, AL	1
12	PAOZZ	74545	SHC-1098-ZP	.STRAIN RELIEF CONNECTOR	1
13	XDOZZ	60984	41008-01	.CONTROL BOX.....	1
14	PAOZZ	60984	41017-01	.NPL, ON.....	1
15	PAOZZ	60984	41017-03	.NPL, PUMP.....	1
16	PAOZZ	60984	41017-05	.NPL, OFF	1
17	PAOZZ	60984	41017-07	.NPL, POWER ON	1
18	PAOZZ	60984	41017-11	.NPL, RAISE	3
19	PAOZZ	60984	41017-13	.NPL, LOWER	3
20	PAOZZ	60984	41017-15	.NPL, TAIL	1
21	PAOZZ	60984	41017-17	.NPL, LEFT	1
22	PAOZZ	60984	41017-21	.NPL, RIGHT.....	1
23	PAOZZ	68592	50151-BK-SIL	.BOOT, RUBBER	4
				END OF FIGURE	

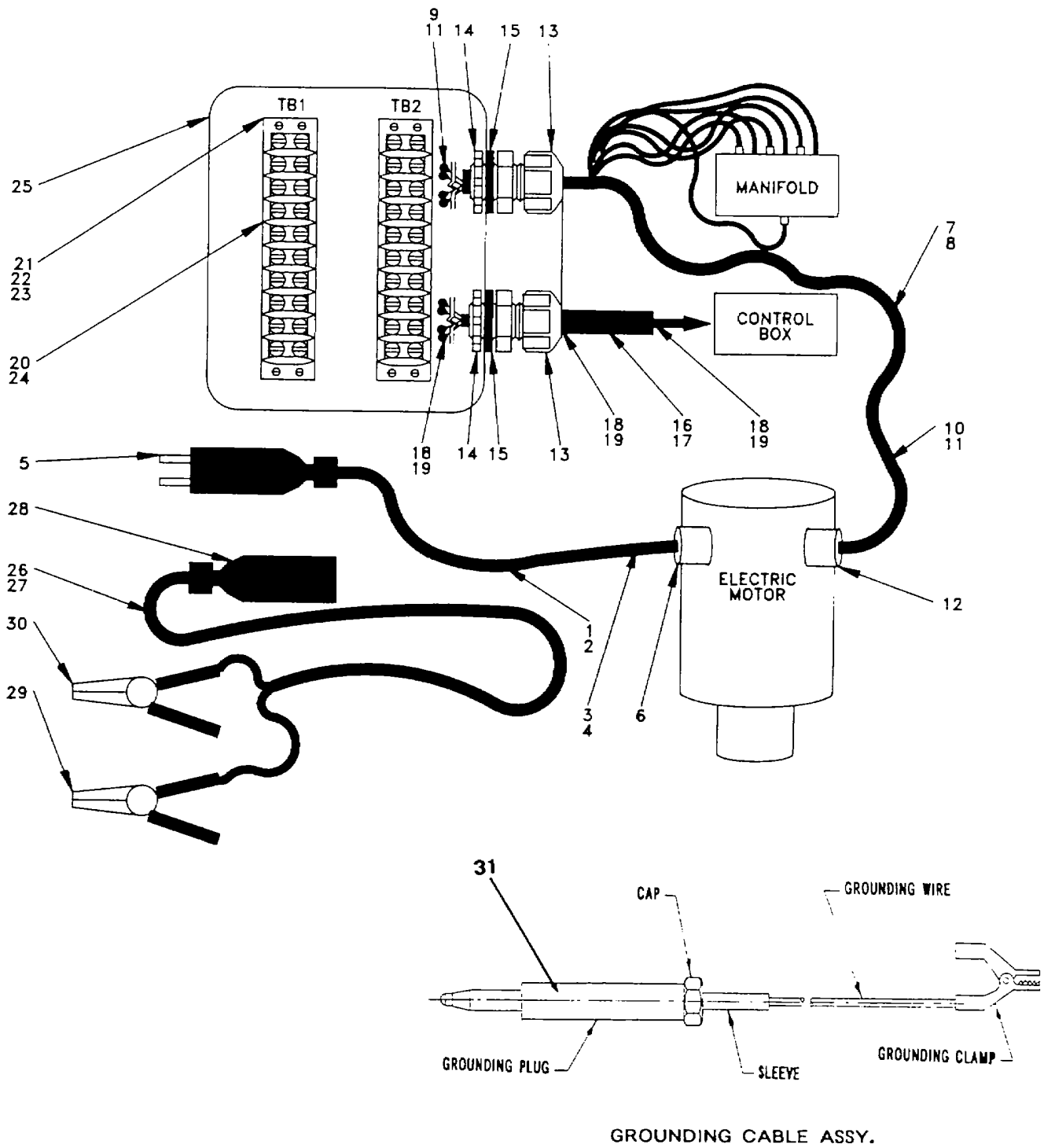

Figure 8. Electrical Components and Wiring Assembly

SECTION II. REPAIR PARTS AND SPECIAL TOOLS LIST

(1) ITEM NO.	(2) SMR CODE	(3) CAGE CODE	(4) PART NUMBER	(5) DESCRIPTION AND USABLE ON CODE (UOC)	(6) QTY
				GROUP 04: ELECTRICAL SYSTEM GROUP 0405: WIRING AND CABLES	
				FIGURE 8. ELECTRICAL COMPO- NENTS AND WIRING ASSEMBLY	
	PAFFF	60984	20084-10	ELECTRICAL COMPONENTS AND WIRING ASSEMBLY (SEE FIGURE 1 FOR NHA)	
1	XDFZZ	60984	60058-10	..CABLE ASSY, POWER	1
2	PAFZZ	5P990	8/2 TYPE SEOOW-A	..CABLE	1
3	PAFZZ	59730	RD8-38	..TERMINAL RING	2
4	PAFZZ	59730	WC--S	..WIRE MARKER	4
5	PAFZZ	80495	R68G1B	..RECEPTACLE, POWER.....	1
6	PAFZZ	56501	2942	..STRAIN RELIEF CONNECTOR	1
7	XDFZZ	60984	60061-10	..CABLE ASSY, MOTOR CONTROL.....	1
8	PAFZZ	07759	14/3 TYPE SO	..CABLE	1
9	PAFZZ	96906	MS25036-107	..TERMINAL RING	3
10	PAFZZ	59730	RB14-10	..TERMINAL RING	3
11	PAFZZ	59730	WC--S	..WIRE MARKER	6
12	PAFZZ	56501	2534	..STRAIN RELIEF CONNECTOR	1
13	PAFZZ	56501	2535	..STRAIN RELIEF CONNECTOR	2
14	PAFZZ	56501	142	..LOCKNUT	2
15	PAFZZ	56501	5303	..SEAL RING	2
16	XDFZZ	60984	60060-10	..CABLE ASSY, CONTROL BOX.....	1
17	PAFZZ	07759	16/10 TYPE SO	..CABLE	1
18	PAFZZ	96906	MS25036-107	..TERMINAL RING	16
19	PAFZZ	59730	WC--S	.. WIRE MARKER	16
20	PAFZZ	26405	110	..TERMINAL BOARD (W/6-32 X 1/4 SCREWS)	2
21	PAFZZ	96906	MS51959-34	..SCREW, MACH, FLH.....	8
22	PAFZZ	96906	MS35338-98	..WASHER, LOCK.....	8
23	PAFZZ	96906	MS35649-262	..NUT, PLAIN, HEX.....	8
24	PAFZZ	96906	MS600101A	..MARKER STRIP	2
25	XDFFF	60984	41027-01	..JUNCTION BOX (ALTERED ITEM)	1
26	PAFFF	60984	60059-10	..ADAPTER ASSY, POWER CABLE.....	1
27	PAFZZ	5P990	8/2 TYPE SEOOW-A	..CABLE	1
28	PAFZZ	96906	MS25488-25	..PLUG, POWER	1
29	PAFZZ	39428	7236K281	..CLIP, ALLIGATOR (RED)	1
30	PAFZZ	39428	7236K282	..CLIP, ALLIGATOR (BLACK).....	1
31	XDFZZ	96906	M83413/1-50	..GROUNDING CABLE	1
				END OF FIGURE	

SECTION III. SPECIAL TOOLS LIST

There are no special tools used for Hydraulic Kneeling/Erecting cart.

CROSS-REFERENCE INDEX

A. NATIONAL STOCK NUMBER INDEX

STOCK NUMBER	FIGURE	ITEM	STOCK	NUMBER	FIGURE	ITEM
--------------	--------	------	-------	--------	--------	------

B. PART NUMBER INDEX

CAGE	PART NUMBER	STOCK NUMBER	FIGURE	ITEM
70587	A-100-W		5	9
84256	AT502-S2-1032		5	13
54846	CVI-10-B-0-5		3	9
59793	DFBN/HC3OG3B1.0/12		1	7
98003	HC83314-42-LALB-SS		2	17
75665	L-075		4	10
24346	LSP101-08-01		5	15
95263	L59D-R24-W		7	4
96906	M83413/1-50		8	31
96906	MS21044N06		2	20
96906	MS21044N3		4	23
96906	MS21044N3		2	12
96906	MS21044N3		4	32
96906	MS21044N3		2	3
96906	MS21044N3		4	29
96906	MS21044N3		1	19
96906	MS21318-19		1	27
96906	MS21318-19		3	12
96906	MS25036-107		8	9
96906	MS25036-107		8	18
96906	MS25488-25		8	28
96906	MS27183-10		1	5
96906	MS27183-14		1	23
96906	MS27183-23		1	21
96906	MS27183-5		2	19
96906	MS27183-8		4	28
96906	MS29512-4		3	15
96906	MS35206-230		2	18
96906	MS35206-247		4	35
96906	MS35206-247		4	6
96906	MS35207-263		4	27
96906	MS35207-263		4	22
96906	MS35207-263		4	31
96906	MS35338-42		4	36
96906	MS35338-42		4	7
96906	MS35338-44		1	4
96906	MS35338-44		4	9
96906	MS35338-44		2	15
96906	MS35338-46		1	11
96906	MS35338-46		4	3
96906	MS35338-98		8	22
96906	MS35649-262		8	23
96906	MS51504B6-8		5	16
96906	MS51504B8-8		5	17
96906	MS51510B6		6	5

CROSS-REFERENCE INDEX

B. PART NUMBER INDEX

CAGE	PART NUMBER	STOCK NUMBER	FIGURE	ITEM
96906	MS51525B6		3	3
96906	MS51527B6		6	3
96906	MS51527B6-8		6	7
96906	MS51527B8		6	2
96906	MS51844-22		5	4
96906	MS51943-31		1	14
96906	MS51959-30		7	1
96906	MS51959-34		8	21
96906	MS51967-2		1	3
96906	MS51967-2		2	16
96906	MS600101A		8	24
96906	MS90725-10		4	8
96906	MS90725-55		1	22
96906	MS90725-58		4	2
96906	MS90725-6		2	14
96906	MS90725-6		1	13
96906	MS90726-3		1	10
54846	NVI-10-K-0		3	7
78357	PDC-12		3	5
59730	RB14-10		8	10
59730	RD8-38		8	3
54846	RV6-10-C-0-100-3000 PSI		3	2
80495	R68G1B		8	5
74545	SHC-1098-ZP		7	12
54846	SV3-10-C-0-24DW		3	8
54846	SV4-10-0-0-24DW		3	4
14140	TFP1002.6DCI06		4	1
59730	WC--S		8	4
59730	WC--S		8	19
59730	WC--S		8	11
94222	01-13-45		2	5
60984	1ARM-X588		4	16
OG8T2	IA761		5	18
60984	IBCA-01071		4	18
60984	1BLT-01819		4	13
60984	1BRG-00818		4	15
60984	1BRU-00040		4	19
60984	1CSA-X588		4	17
60984	1DEC-00500		4	14
60984	1NEG-00149		4	20
26405	110		8	20
28891	124-903		4	26
07759	14/3 TYPE SO		8	8
56501	142		8	14
56501	143		7	8

CROSS-REFERENCE INDEX

B. PART NUMBER INDEX

CAGE	PART NUMBER	STOCK NUMBER	FIGURE	ITEM
07759	16/10 TYPE SO		8	17
60984	20078-10		1	9
60984	20079-01		5	5
60984	20079-03		5	8
60984	20079-05		5	2
60984	20079-10		1	12
60984	20080-10		1	1
60984	20081-10		1	2
60984	20082-10		1	15
60984	20083-10		1	16
60984	20084-10		1	17
62091	25.300-5000PSI-1/4NPT		3	1
56501	2534		8	12
56501	2535		8	13
56501	2942		8	6
13445	30055-10		4	30
00624	3302-4		3	6
60984	4BD-X588		4	12
30780	4HP50N-S		3	10
60984	40179-1		1	18
60984	40179-1		2	11
60984	40179-1		1	8
60984	40179-1		2	2
60984	41001-01		5	14
60984	41002-01		4	5
60984	41003-01		2	13
60984	41003-11		1	29
60984	41003-33		2	7
60984	41003-35		2	9
60984	41003-37		2	8
60984	41005-01		4	37
60984	41006-01		4	34
60984	41007-01		4	4
60984	41007-03		4	11
60984	41008-01		7	13
60984	41009-01		2	4
60984	41010-01		2	1
60984	41013-01		2	10
60984	41016-01		7	5
60984	41017-01		7	14
60984	41017-03		7	15
60984	41017-05		7	16

B. PART NUMBER INDEX

CAGE	PART NUMBER	STOCK NUMBER	FIGURE	ITEM
60984	41017-07		7	17
60984	41017-11		7	18
60984	41017-13		7	19
60984	41017-15		7	20
60984	41017-17		7	21
60984	41017-21		7	22
60984	41018-01		1	24
60984	41019-01		1	26
60984	41019-03		1	25
60984	41019-05		3	11
60984	41019-07		5	21
60984	41019-11		5	23
60984	41019-13		5	22
60984	41019-15		5	20
60984	41023-01		1	6
60984	41024-01		1	28
60984	41025-01		7	11
60984	41026-01		7	10
60984	41027-01		8	25
60984	41037-01		4	33
60984	41039-01		4	21
39428	4549K571		5	19
39428	4638K514		5	1
68592	50151-BK-SIL		7	23
60984	50167-01		3	13
60984	50168-01		5	3
60984	50169-01		6	1
60984	50170-01		6	4
60984	50171-01		6	6
60984	50172-01		6	8
60984	50173-01		6	9
60984	50174-01		6	10
60984	50175-01		6	11
60984	50176-01		6	12
56501	5303		8	15
56501	5304		7	9
60984	60058-10		8	1
60984	60059-10		8	26
60984	60060-10		8	16
60984	60061-10		8	7
60984	60062-01		4	24
60984	60062-03		4	25
60984	60062-05		4	38
39428	7236K281		8	29
39428	7236K282		8	30

CROSS-REFERENCE INDEX

B. PART NUMBER INDEX

CAGE	PART NUMBER	STOCK NUMBER	FIGURE	ITEM
5P990	8/2 TYPE SEOOW-A		8	2
5P990	8/2 TYPE SEOOW-A		8	27
39428	8352T28		1	20
68592	8510K1		7	2
68592	8511K2		7	3
39428	90283A110		7	6
39428	90675A005		7	7
39428	91079A032		3	14
39428	91773A827		5	6
39428	91773A827		5	10
39428	91842A011		5	12
39428	92146A011		5	7
39428	92146A011		5	11
39428	93085K18		1	30
39428	9540K28		2	6

CROSS-REFERENCE INDEX

C. FIGURE AND ITEM NUMBER INDEX

FIGURE	ITEM	STOCK NUMBER	CAGE	PART NUMBER
1	1		60984	20080-10
1	2		60984	20081-10
1	3		96906	MS51967-2
1	4		96906	MS35338-44
1	5		96906	MS27183-10
1	6		60984	41023-01
1	7		59793	DFBN/HC30G3B1.0/12
1	8		60984	40179-1
1	9		60984	20078-10
1	10		96906	MS90726-3
1	11		96906	MS35338-46
1	12		60984	20079-10
1	13		96906	MS90725-6
1	14		96906	MS51943-31
1	15		60984	20082-10
1	16		60984	20083-10
1	17		60984	20084-10
1	18		60984	40179-1
1	19		96906	MS21044N3
1	20		39428	8352T28
1	21		96906	MS27183-23
1	22		96906	MS90725-55
1	23		96906	MS27183-14
1	24		60984	41018-01
1	25		60984	41019-03
1	26		60984	41019-01
1	27		96906	MS21318-19
1	28		60984	41024-01
1	29		60984	41003-11
1	30		39428	93085K18
2	1		60984	41010-01
2	2		60984	40179-1
2	3		96906	MS21044N3
2	4		60984	41009-01
2	5		94222	01-13-45
2	6		39428	9540K28
2	7		60984	41003-33
2	8		60984	41003-37
2	9		60984	41003-35
2	10		60984	41013-01
2	11		60984	40179-1
2	12		96906	MS21044N3
2	13		60984	41003-01
2	14		96906	MS90725-6
2	15		96906	MS35338-44

CROSS-REFERENCE INDEX

C. FIGURE AND ITEM NUMBER INDEX

FIGURE	ITEM	STOCK NUMBER	CAGE	PART NUMBER
2	16		96906	MS51967-2
2	17		98003	HC83314-42-LALB-SS
2	18		96906	MS35206-230
2	19		96906	MS27183-5
2	20		96906	MS21044N06
3	1		62091	25.300-5000PSI-1/4NPT
3	2		54846	RV6-10-C-0-100-3000 PSI
3	3		96906	MS51525B6
3	4		54846	SV4-10-0-0-24DW
3	5		78357	PDC-12
3	6		00624	3302-4
3	7		54846	NVI-10-K-0
3	8		54846	SV3-10-C-0-24DW
3	9		54846	CV1-10-B-0-5
3	10		30780	4HP50N-S
3	11		60984	41019-05
3	12		96906	MS21318-19
3	13		60984	50167-01
3	14		39428	91079A032
3	15		96906	MS29512-4
4	1		14140	TFP1002.6DCI06
4	2		96906	MS90725-58
4	3		96906	MS35338-46
4	4		60984	41007-01
4	5		60984	41002-01
4	6		96906	MS35206-247
4	7		96906	MS35338-42
4	8		96906	MS90725-10
4	9		96906	MS35338-44
4	10		75665	L-075
4	11		60984	41007-03
4	12		60984	4BD-X588
4	13		60984	1BLT-01819
4	14		60984	1DEC-00500
4	15		60984	1BRG-00818
4	16		60984	1ARM-X588
4	17		60984	1CSZ-X588
4	18		60984	IBCA-01071
4	19		60984	1BRU-00040
4	20		60984	1NEG-00149
4	21		60984	41039-01
4	22		96906	MS35207-263

CROSS-REFERENCE INDEX

C. FIGURE AND ITEM NUMBER INDEX

FIGURE	ITEM	STOCK NUMBER	CAGE	PART NUMBER
4	23		96906	MS21044N3
4	24		60984	60062-01
4	25		60984	60062-03
4	26		28891	124-903
4	27		96906	MS35207-263
4	28		96906	MS27183-8
4	29		96906	MS21044N3
4	30		13445	30055-10
4	31		96906	MS35207-263
4	32		96906	MS21044N3
4	33		60984	41037-01
4	34		60984	41006-01
4	35		96906	MS35206-247
4	36		96906	MS35338-42
4	37		60984	41005-01
4	38		60984	60062-05
5	1		39428	4638K514
5	2		60984	20079-05
5	3		60984	50168-01
5	4		96906	MS51844-22
5	5		60984	20079-01
5	6		39428	91773A827
5	7		39428	92146A011
5	8		60984	20079-03
5	9		70587	A-100-W
5	10		39428	91773A827
5	11		39428	92146A011
5	12		39428	91842A011
5	13		84256	AT502-S2-1032
5	14		60984	41001-01
5	15		24346	LSP101-08-01
5	16		96906	MS51504B6-8
5	17		96906	MS51504B8-8
5	18		OG8T2	IA761
5	19		39428	4549K571
5	20		60984	41019-15
5	21		60984	41019-07
5	22		60984	41019-13
5	23		60984	41019-11
6	1		60984	50169-01
6	2		96906	MS51527B8
6	3		96906	MS51527B6
6	4		60984	50170-01
6	5		96906	MS51510B6
6	6		60984	50171-01

CROSS-REFERENCE INDEX

C. FIGURE AND ITEM NUMBER INDEX

FIGURE	ITEM	STOCK NUMBER	CAGE	PART NUMBER
6	7		96906	MS51527B6-8
6	8		60984	50172-01
6	9		60984	50173-01
6	10		60984	50174-01
6	11		60984	50175-01
6	12		60984	50176-01
7	1		96906	MS51959-30
7	2		68592	8510K1
7	3		68592	8511K2
7	4		95263	L59D-R24-W
7	5		60984	41016-01
7	6		39428	90283A110
7	7		39428	90675A005
7	8		56501	143
7	9		56501	5304
7	10		60984	41026-01
7	11		60984	41025-01
7	12		74545	SHC-1098-ZP
7	13		60984	41008-01
7	14		60984	41017-01
7	15		60984	41017-03
7	16		60984	41017-05
7	17		60984	41017-07
7	18		60984	41017-11
7	19		60984	41017-13
7	20		60984	41017-15
7	21		60984	41017-17
7	22		60984	41017-21
7	23		68592	50151-BK-SIL
8	1		60984	60058-10
8	2		5P990	8/2 TYPE SEOOW-A
8	3		59730	RD8-38
8	4		59730	WC--S
8	5		80495	R68G1B
8	6		56501	2942
8	7		60984	60061-10
8	8		07759	14/3 TYPE SO
8	9		96906	MS25036-107
8	10		59730	RB14-10
8	11		59730	WC--S
8	12		56501	2534
8	13		74545	2535
8	14		56501	142
8	15		56501	5303
8	16		60984	60060-10

CROSS-REFERENCE INDEX

C. FIGURE AND ITEM NUMBER INDEX

FIGURE	ITEM	STOCK NUMBER	CAGE	PART NUMBER
8	17		07759	16/10 TYPE SO
8	18		96906	MS25036-107
8	19		59730	WC--S
8	20		26405	110
8	21		96906	MS51959-34
8	22		39428	MS35338-98
8	23		96906	MS35649-262
8	24		96906	MS600101A
8	25		60984	41027-01
8	26		60984	60059-10
8	27		5P990	8/2 TYPE SEOW-A
8	28		96906	MS25488-25
8	29		39428	7236K281
8	30		39428	7236K282
8	31		96906	M83413/1-50

APPENDIX D

EXPENDABLE SUPPLIES AND MATERIALS LIST

SECTION I. INTRODUCTION

D-1. Scope. This appendix lists expendable supplies and materials needed to operate and maintain the Hydraulic Kneeling/Erecting Cart Part Number 100640. These items are authorized to you by CTA 50970, Expendable Items (Except Medical, Class V, Repair Parts, and Heraldic Items).

D-2. Explanation of Columns.

- a. Column (1) - Item Number. This number is assigned to the entry in the listing.
- b. Column (2) - Level. This column identifies the lowest level of maintenance that requires the listed item.

O - Aviation Unit Maintenance (AVUM)
 F - Aviation Intermediate Maintenance (AVIM)

c. Column (3) - National Stock Number. This is the national stock number assigned to the item; it is to be used to request or requisition the item.

d. Column (4) - Description. Indicates the Federal item name and, if required, a description to identify the item.

e. Column (5) - Unit of Measure. (U/M) Indicates the measure used in performing the actual maintenance function. This measure is expressed by a two-character alphabetical abbreviation (e.g., ea. in pr). If the unit of measure differs from the unit of issue, requisition the lowest unit of issue that will satisfy your requirements.

SECTION II. EXPENDABLE SUPPLIES AND MATERIALS LIST

(1) ITEM NUMBER	(2) LEVEL	(3) NATIONAL STOCK NUMBER	(4) DESCRIPTION	(5) U/M
1	O	9150-00-190-0904	Grease, Automotive and Artillery MIL-G-10924	lb

SECTION II. EXPENDABLE SUPPLIES AND MATERIALS LIST

(1) ITEM NUMBER	(2) LEVEL	(3) NATIONAL STOCK NUMBER	(4) DESCRIPTION	(5) U/M
2	F	6850-00-285-8011	Solvent, Dry Cleaning, P-D-680	gl
3	O	9150-00-223-4134	Fluid, Hydraulic MIL-H-5606	gl
4	O	9150-00-149-7431	Fluid, Hydraulic MIL-H-83282	gl
5	O	9150-00-231-9062	Oil, Lubricating W-L-800	gl
6	O	8030-00-889-3535	Tape, Antlseize MIL-T-27730	roll
7	O	9150-00-935-9807	Fluid, Hydraulic (Preservative) MIL-H-6083	gl

ALPHABETICAL INDEX

Subject		Paragraph
A		
Adjustment, Relief Valve.....		3-19
B		
Bleed Procedure, Pre-operation.....		2-6
C		
Cables		
Inspection.....		3-36
Service.....		3-36
Repair.....		3-36
Removal.....		3-36
Installation.....		3-36
Calibration.....		1-6
Calibration, Pressure Gage.....		3-18
Capabilities and Features.....		1-8
Characteristics and Purpose.....		1-7
Check Valve		
Inspection.....		3-24
Removal.....		3-24
Repair.....		3-24
Installation.....		3-24
Circuit Breaker		
Inspection.....		3-34
Removal.....		3-34
Installation.....		3-34
Cleaning, Suction Strainer.....		3-29
Controls and Indicators.....		2-1
Control Panel Cover		
Inspection.....		3-14
Repair.....		3-14
Removal.....		3-14
Installation.....		3-14
D		
Destruction of Army Materiel to Prevent Enemy Use.....		1-3
Door, Cabinet		
Inspection.....		3-15
Repair.....		3-15
Removal.....		3-15
Installation.....		3-15
Door Lock		
Inspection.....		3-16
Removal.....		3-16
Installation.....		3-16

Subject	D (Continued)	Paragraph
Drain and Flush Hydraulic Reservoir.....		2-3
	E	
Electrical Wiring/Components Assembly, Description.....		1-9
Electromagnetic Interference Filter		
Inspection.....		3-34
Removal.....		3-34
Installation.....		3-34
Equipment Improvement Recommendations, Reporting.....		1-5
Equipment, Test.....		3-4
	F	
Filler/Breather		
Inspection.....		3-27
Removal.....		3-27
Installation.....		3-27
Filter		
Inspection.....		3-26
Service.....		3-26
Removal.....		3-26
Installation.....		3-26
Test.....		3-26
Flexible Coupling		
Inspection.....		3-33
Removal.....		3-33
Installation.....		3-33
Frame/Cabinet Assembly, Description.....		1-9
Functional Description.....		1-10
	G	
Gear Pump		
Inspection.....		3-17
Removal.....		3-17
Installation.....		3-17
	H	
Hydraulic Cart Operation.....		2-4
Hydraulic Piping		
Inspection.....		3-31
Repair.....		3-31
Removal.....		3-31
Installation.....		3-31
Test.....		3-31
Hydraulic Piping Assembly.....		1-9

Subject	Paragraph
Indicator Light	
Inspection.....	3-35
Service.....	3-35
Removal.....	3-35
Installation.....	3-35
Information	
General (PMCS).....	3-9
General (Maintenance).....	3-12
General (Storage or Shipment).....	3-37
Inspection	
Cabinet Door.....	3-15
Cables.....	3-36
Check Valve.....	3-24
Circuit Breaker.....	3-34
Control Panel Cover.....	3-14
Door Lock.....	3-16
Electromagnetic Filter.....	3-34
Filler/Breather.....	3-27
Filter.....	3-26
Flexible Coupling.....	3-33
Gear Pump.....	3-17
Hydraulic Piping.....	3-31
Indicator Light.....	3-35
Latch Assembly.....	3-14
Manifold.....	3-25
Motor, DC.....	3-32
Needle Valve.....	3-23
Needle Valve Knob.....	3-22
Pressure Gage.....	3-18
Quick Disconnect.....	3-21
Relief Valve.....	3-19
Reservoir Tank.....	3-30
Sight Glass.....	3-28
Solenoid Valve.....	3-20
Special Adapter.....	3-27
Start Relay.....	3-34
Suction Strainer.....	3-29
Switches.....	3-35
Wheel.....	3-13
Wiring.....	3-36
Inspection, Initial.....	3-7
Installation	
Cabinet Door.....	3-15
Cables.....	3-36
Check Valve.....	3-24
Circuit Breaker.....	3-34
Control Panel Cover.....	3-14
Door Lock.....	3-16
Electromagnet IC Filter.....	3-34

Subject

Paragraph

I (Continued)

Installation (Continued)	
Filter	3-26
Filler/Breather.....	3-27
Flexible Coupling.....	3-33
Gear Pump.....	3-17
Hydraulic Piping.....	3-31
Indicator Light.....	3-35
Latch Assembly.....	3-14
Manifold.....	3-25
Motor, DC.....	3-32
Needle Valve.....	3-23
Needle Valve Knob.....	3-22
Pressure Gage.....	3-18
Quick Disconnect.....	3-21
Relief Valve.....	3-19
Reservoir Tank.....	3-30
Sight Glass.....	3-28
Solenoid Valve.....	3-20
Special Adapter.....	3-27
Start Relay.....	3-34
Suction Strainer.....	3-29
Switches.....	3-35
Wheel.....	3-13
Wiring	3-36
K	
Kneeling and Erecting Operations for C141B and Truck	
Shipment.....	2-8
Kneeling and Erecting Operations for C5 Shipment (Rear Door Load Only).....	2-9
L	
Latch Assembly	
Inspection.....	3-14
Repair	3-14
Removal.....	3-14
Installation.....	3-14
Lubrication.....	3-10
M	
Maintenance Forms, Records, and Reports.....	1-2
Major Components, Location and Description.....	1-9
Manifold	
Inspection.....	3-25
Removal.....	3-25
Installation.....	3-25

Subject	Paragraph
M (Continued)	
Manifold Assembly, Description.....	1-9
Motor, DC	
Inspection.....	3-32
Removal.....	3-32
Repair.....	3-32
Installation.....	3-32
Motor and Pump Assembly, Description.....	1-9
N	
Needle Valve	
Inspection.....	3-23
Removal.....	3-23
Repair.....	3-23
Installation.....	3-23
Needle Valve Knob	
Inspection.....	3-22
Removal.....	3-22
Installation.....	3-22
O	
Operation, Hydraulic Cart.....	2-4
P	
PMCS Procedures.....	2-2
Preliminary Checks.....	2-5
Pre-operation Bleed Procedure.....	2-6
Pre-operation Relief Valve Setting Check.....	2-7
Pressure Gage	
Inspection.....	3-18
Removal.....	3-18
Calibration.....	3-18
Installation.....	3-18
Q	
Quick Disconnect	
Inspection.....	3-21
Removal.....	3-21
Installation.....	3-21

Subject	R	Paragraph
Relief Valve		
Inspection.....		3-19
Adjustment.....		3-19
Removal.....		3-19
Repair.....		3-19
Installation.....		3-19
Relief Valve Setting Check, Preoperation.....		2-7
Removal		
Cabinet Door.....		3-15
Cables.....		3-36
Check Valve.....		3-24
Circuit Breaker.....		3-34
Control Panel Cover.....		3-14
Door Lock.....		3-16
Electromagnetic Filter.....		3-34
Filler/Breather.....		3-27
Filter.....		3-26
Flexible Coupling.....		3-33
Gear Pump.....		3-17
Hydraulic Piping.....		3-31
Indicator Light.....		3-35
Latch Assembly.....		3-14
Manifold.....		3-25
Motor, DC.....		3-32
Needle Valve.....		3-23
Needle Valve Knob.....		3-22
Pressure Gage.....		3-18
Quick Disconnect.....		3-21
Relief Valve.....		3-19
Reservoir Tank.....		3-30
Sight Glass.....		3-28
Solenoid Valve.....		3-20
Special Adapter.....		3-27
Start Relay.....		3-34
Suction Strainer.....		3-29
Switches.....		3-35
Wheel.....		3-13
Wiring.....		3-36
Repair		
Cabinet Door.....		3-15
Cables.....		3-36
Check Valve.....		3-24
Control Panel Cover.....		3-14
Hydraulic Piping.....		3-31
Latch Assembly.....		3-14
Motor, DC.....		3-32
Needle Valve.....		3-23
Relief Valve.....		3-19
Reservoir Tank.....		3-30

Subject	R (Continued)	Paragraph
Repair (Continued)		
Solenoid Valve.....		3-20
Wiring		3-36
Repair Parts.....		3-5
Reservoir Assembly, Description.....		1-9
Reservoir Tank		
Inspection.....		3-30
Repair.....		3-30
Removal.....		3-30
Installation.....		3-30
	S	
Scope		1-1
Service		
Cables.....		3-36
Filter.....		3-26
Hydraulic System.....		3-8
Indicator Light.....		3-35
Switches.....		3-35
Wheel.....		3-13
Wiring		3-36
Servicing Hydraulic System.....		3-2
Sight Glass, Fluid Level		
Inspection.....		3-28
Removal.....		3-28
Installation.....		3-28
Solenoid Valve		
Inspection.....		3-20
Removal.....		3-20
Repair		3-20
Installation.....		3-20
Special Adapter		
Inspection.....		3-27
Removal.....		3-27
Installation.....		3-27
Start Relay		
Inspection.....		3-34
Removal.....		3-34
Installation.....		3-34
Storage or Shipment, Preparation.....		1-4
Suction strainer		
Inspection.....		3-29
Removal.....		3-29
Cleaning.....		3-29
Installation.....		3-29

Subject	S (Continued)	Paragraph
Switches		
Inspection.....		3-35
Service.....		3-35
Removal.....		3-35
Installation.....		3-35
T		
Test		
Filter.....		3-26
Hydraulic Piping.....		3-31
Tools, Common.....		3-2
Tools, Special.....		3-3
Troubleshooting.....		3-11
U		
Unpacking and Installation.....		3-6
W		
Wheel		
Inspection.....		3-13
Service.....		3-13
Removal.....		3-13
Installation.....		3-13
Wiring		
Inspection.....		3-36
Service.....		3-36
Repair.....		3-36
Removal.....		3-36
Installation.....		3-36

TM 1-1730-231-13&P

By Order of the Secretary of the Army

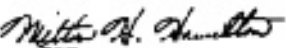
Official: 

MILTON H. HAMILTON
*Administrative Assistant to the
Secretary of the Army*

GORDON R. SULLIVAN
*General, United States Army
Chief of Staff*

DISTRIBUTION:

To be distributed in accordance with DA Form 1281-E, block no. 3299, requirements for TM 1-1730-231-13&P.

U.S. GOVERNMENT PRINTING OFFICE: 1992 654 028 / 60419

RECOMMENDED CHANGES TO EQUIPMENT TECHNICAL PUBLICATIONS

SOMETHING WRONG WITH PUBLICATION



*THEN...JOT DOWN THE
DOPE ABOUT IT ON THIS FORM.
CAREFULLY TEAR IT OUT, FOLD IT
AND DROP IT IN THE MAIL.*

FROM: (PRINT YOUR UNIT'S COMPLETE ADDRESS)

DATE SENT

PUBLICATION NUMBER

PUBLICATION DATE

PUBLICATION TITLE

BE EXACT PIN-POINT WHERE IT IS

PAGE
NO.

PARA-
GRAPH

FIGURE
NO.

TABLE
NO.

**IN THIS SPACE, TELL WHAT IS WRONG
AND WHAT SHOULD BE DONE ABOUT IT.**

TEAR ALONG PERFORATED LINE

PRINTED NAME, GRADE OR TITLE AND TELEPHONE NUMBER

SIGN HERE

The Metric System and Equivalents

Linear Measure

1 centimeter = 10 millimeters = .39 inch
 1 decimeter = 10 centimeters = 3.94 inches
 1 meter = 10 decimeters = 39.37 inches
 1 dekameter = 10 meters = 32.8 feet
 1 hectometer = 10 dekameters = 328.08 feet
 1 kilometer = 10 hectometers = 3,280.8 feet

Weights

1 centigram = 10 milligrams = .15 grain
 1 decigram = 10 centigrams = 1.54 grains
 1 gram = 10 decigram = .035 ounce
 1 decagram = 10 grams = .35 ounce
 acres
 1 hectogram = 10 decagrams = 3.52 ounces
 1 kilogram = 10 hectograms = 2.2 pounds
 1 quintal = 100 kilograms = 220.46 pounds
 1 metric ton = 10 quintals = 1.1 short tons

Liquid Measure

1 centiliter = 10 milliliters = .34 fl. ounce
 1 deciliter = 10 centiliters = 3.38 fl. ounces
 1 liter = 10 deciliters = 33.81 fl. ounces
 1 dekaliter = 10 liters = 2.64 gallons
 1 hectoliter = 10 dekaliters = 26.42 gallons
 1 kiloliter = 10 hectoliters = 264.18 gallons

Square Measure

1 sq. centimeter = 100 sq. millimeters = .155 sq. inch
 1 sq. decimeter = 100 sq. centimeters = 15.5 sq. inches
 1 sq. meter (centare) = 100 sq. decimeters = 10.76 sq. feet
 1 sq. dekameter (are) = 100 sq. meters = 1,076.4 sq. feet
 1 sq. hectometer (hectare) = 100 sq. dekameters = 2.47
 1 sq. kilometer = 100 sq. hectometers = .386 sq. mile

Cubic Measure

1 cu. centimeter = 1000 cu. millimeters = .06 cu. inch
 1 cu. decimeter = 1000 cu. centimeters = 61.02 cu. inches
 1 cu. meter = 1000 cu. decimeters = 35.31 cu. feet

Approximate Conversion Factors

<i>To change</i>	<i>To</i>	<i>Multiply by</i>	<i>To change</i>	<i>To</i>	<i>Multiply by</i>
inches	centimeters	2.540	ounce-inches	Newton-meters	.007062
feet	meters	.305	centimeters	inches	.394
yards	meters	.914	meters	feet	3.280
miles	kilometers	1.609	meters	yards	1.094
square inches	square centimeters	6.451	kilometers	miles	.621
square feet	square meters	.093	square centimeters	square inches	.155
square yards	square meters	.836	square meters	square feet	10.764
square miles	square kilometers	2.590	square meters	square yards	1.196
acres	square hectometers	.405	square kilometers	square miles	.386
cubic feet	cubic meters	.028	square hectometers	acres	2.471
cubic yards	cubic meters	.765	cubic meters	cubic feet	35.315
fluid ounces	milliliters	29.573	cubic meters	cubic yards	1.308
pints	liters	.473	milliliters	fluid ounces	.034
quarts	liters	.946	liters	pints	2.113
gallons	liters	3.785	liters	quarts	1.057
ounces	grams	28.349	liters	gallons	.264
pounds	kilograms	.454	grams	ounces	.035
short tons	metric tons	.907	kilograms	pounds	2.205
pound-feet	Newton-meters	1.356	metric tons	short tons	1.102
pound-inches	Newton-meters	.11296			

Temperature (Exact)

°F	Fahrenheit temperature	5/9 (after subtracting 32)	Celsius temperature	°C
----	---------------------------	-------------------------------	------------------------	----

PIN: 070526-000

This fine document...

Was brought to you by me:



[Liberated Manuals -- free army and government manuals](#)

Why do I do it? I am tired of sleazy CD-ROM sellers, who take publicly available information, slap “watermarks” and other junk on it, and sell it. Those masters of search engine manipulation make sure that their sites that sell free information, come up first in search engines. They did not create it... They did not even scan it... Why should they get your money? Why are not letting you give those free manuals to your friends?

I am setting this document FREE. This document was made by the US Government and is NOT protected by Copyright. Feel free to share, republish, sell and so on.

I am not asking you for donations, fees or handouts. If you can, please provide a link to liberatedmanuals.com, so that free manuals come up first in search engines:

<A HREF=<http://www.liberatedmanuals.com/>>Free Military and Government Manuals

- Sincerely
Igor Chudov
<http://igor.chudov.com/>
- [Chicago Machinery Movers](#)