

# \*TB 9-6625-2351-24

DEPARTMENT OF THE ARMY TECHNICAL BULLETIN

## CALIBRATION PROCEDURE FOR SPECTRUM ANALYZER HEWLETT-PACKARD, MODEL 8562A

Headquarters, Department of the Army, Washington, DC

2 July 2008

*Distribution Statement A: Approved for public release; distribution is unlimited*

### REPORTING OF ERRORS AND RECOMMENDING IMPROVEMENTS

You can improve this manual. If you find any mistakes or if you know of a way to improve these procedures, please let us know. Mail your letter or DA Form 2028 (Recommended Changes to Publications and Blank Forms) directly to: Commander, U.S. Army Aviation and Missile Command, ATTN: AMSAM-MMC-MA-NP, Redstone Arsenal, AL 35898-5000. A reply will be furnished to you. You may also send in your comments electronically to our E-mail address: [2028@redstone.army.mil](mailto:2028@redstone.army.mil) or by fax 256-842-6546/DSN 788-6546. For the World Wide Web use: <https://amcom2028.redstone.army.mil>. Instructions for sending an electronic 2028 can be found at the back of this manual.

SECTION		Paragraph	Page
I.	IDENTIFICATION AND DESCRIPTION		
	Test instrument identification .....	1	2
	Forms, records, and reports.....	2	2
	Calibration description .....	3	2
II.	EQUIPMENT REQUIREMENTS		
	Equipment required .....	4	3
	Accessories required .....	5	3
III.	CALIBRATION PROCESS		
	Preliminary instructions.....	6	5
	Equipment setup .....	7	5
	Calibrator output accuracy test .....	8	6
	Displayed average noise level test .....	9	7
	Resolution bandwidth accuracy and selectivity test.....	10	9
	Input attenuator accuracy .....	11	12
	IF gain uncertainty .....	12	14
	Residual FM .....	13	18

\*This bulletin supersedes TB 9-6625-2351-35, dated 4 May 2004.



Table 1. Calibration Description - Continued

Test instrument parameters	Performance specifications
Input attenuator accuracy	Range: 20 to 70 dB, referenced to 10 dB input attenuation Frequency range: 10 kHz to 22 GHz <sup>1</sup> Accuracy: $<\pm 0.6$ dB/10 dB step with a maximum cumulative error of $\pm 1.8$ dB
IF gain uncertainty	Range: 0 to -80 dBm reference level, 10 dB input attenuation Accuracy: $<\pm 1.0$ dB
Residual FM (zero span)	$<50$ Hz X N <sup>2</sup> p-p in 100 mS
Frequency readout accuracy	Frequency range: 9 kHz to 22 GHz <sup>1</sup> Accuracy: $<\pm$ (center frequency x $4 \times 10^{-6}$ + 5% of frequency span + 15% of RES BW + 250 Hz)
Frequency count marker accuracy	Frequency range: 9 kHz to 22 GHz <sup>1</sup> Accuracy: $<\pm(4 \times 10^{-6} + 50 \text{ Hz} \times N^2 + 1 \text{ LSD})$
Frequency span	Range: 0 Hz, 2.5 kHz X N <sup>2</sup> to 19.25 GHz over the 10-division crt horizontal axis, variable in approximately 1% increments or in a 1,2,5, sequence Accuracy (span $\geq 10$ kHz): $<\pm 5\%$
Frequency response (10 dB input attenuation) referenced to 300 MHz	Range: Accuracy: 9 kHz to 2.9 GHz $<\pm 1.5$ dB 2.9 to 6.46 GHz $<\pm 2.5$ dB 6.46 to 13 GHz $<\pm 3.0$ dB 13 to 18 GHz $<\pm 4.0$ dB
Displayed average noise level (no signal at input, 100 Hz RES BW, and 0 dB input attenuation)	Frequency Range: dBm 10 kHz $<-90$ 100 kHz $<-100$ 1 MHz to 2.9 GHz $<-121$ 2.9 to 6.46 GHz $<-121$ 6.46 to 13 GHz $<-110$ 13 to 19.7 GHz <sup>1</sup> $<-105$
Residual responses (no signal at input, 0 dB input attenuation)	Range: 200 kHz to 6.46 GHz Responses: $<-90$ dBm

<sup>1</sup>Limited to 18.0 GHz due to N type input connector.

<sup>2</sup>N is the harmonic mixing mode.

## SECTION II EQUIPMENT REQUIREMENTS

**4. Equipment Required.** Table 2 identifies the specific equipment to be used in this calibration procedure. This equipment is issued with Secondary Transfer Calibration Standards Set AN/GSM-287, AN/GSM-705. Alternate items may be used by the calibrating activity. The items selected must be verified to perform satisfactorily prior to use and must bear evidence of current calibration. The equipment must meet or exceed the minimum use specifications listed in table 2. The accuracies listed in table 2 provide a four-to-one ratio between the standard and TI. Where the four-to-one ratio cannot be met the actual accuracy of the equipment selected is shown in parenthesis.

**5. Accessories Required.** The accessories required for this calibration are common usage accessories, issued as indicated in paragraph 4 above, and are not listed in this calibration procedure.

Table 2. Minimum Specifications of Equipment Required

Common name	Minimum use specifications	Manufacturer and model (part number)
ATTENUATOR	Range: 0 to 12 dB Frequency: 50 MHz	Hewlett-Packard, Model 355C (7910807)
ATTENUATOR (FIXED)	6 dB: Frequency range: 50 MHz to 18 GHz Accuracy: $\pm 0.3$ dB  10 dB: Frequency range: 50 MHz to 18 GHz Accuracy: $\pm 0.5$ dB  20 dB: Frequency range: 50 MHz to 18 GHz Accuracy: $\pm 0.5$ dB	Weinschel, Model 9918-6dB, Model 9918-10dB and Model 9918-20dB
MEASURING RECEIVER	Frequency range: 300 MHz Accuracy: $\pm 300$ Hz dBm range: -9.7 to -10.3 Accuracy: $\pm 0.075$ dBm Frequency response: 10 MHz to 18 GHz (referenced to 300 MHz) at 10 dBm Accuracy: <sup>1</sup>	Measuring receiver system N5530S consisting of: Spectrum Analyzer, Agilent Model E4440A (E4440A), Power meter, Agilent Model E4419B (E4419B), and Sensor module, Agilent Model N5532A opt. 504 (504), 518 (518), 526 (526)
MULTIMETER	Range: 1000 Vdc Accuracy: $\pm 2$ Vdc	Fluke, Model 8840A/AF-05 (AN/GSM-64D)
POWER SPLITTER	Frequency range: 10 MHz to 18 GHz Power range: -10 dBm Accuracy: <sup>1</sup>	Weinschel, Model 1870A (7916839)
SYNTHESIZED SIGNAL GENERATOR	Frequency range: 10 MHz to 18 GHz Power range: 0 to -15 dBm Accuracy: $\pm 1.525$ dBm	ANRITSU, Model 68369NV (68369NV)
SYNTHESIZER/LEVEL GENERATOR	Frequency range: 9 kHz to 50 MHz Amplitude range: -80 to +10 dBm Accuracy: $\pm 0.02$ dB per 10 dB step	Hewlett-Packard, Model 3335AOPT 001-KO6 (MIS-35938)

<sup>1</sup>Combined accuracy of measuring receiver and power splitter is  $\pm 0.375$  dBm.

### SECTION III CALIBRATION PROCESS

#### 6. Preliminary Instructions

a. The instructions outlined in paragraphs 6 and 7 are preparatory to the calibration process. Personnel should become familiar with the entire bulletin before beginning the calibration.

b. Items of equipment used in this procedure are referenced within the text by common name as listed in table 2.

c. Unless otherwise specified, verify the result of each test and, whenever the test requirement is not met, take corrective action before continuing with the calibration. Additional maintenance information is contained in the manufacturer's manual for this TI.

d. When indications specified in paragraphs 8 through 17 are not within tolerance, perform the power supply check prior to making adjustments. After adjustments are made, repeat paragraphs 8 through 17. Do not perform power supply check if all other parameters are within tolerance.

e. Unless otherwise specified, all controls and control settings refer to TI.

**7. Equipment Setup**

**WARNING**

HIGH VOLTAGE is used or exposed during the performance of this calibration. DEATH ON CONTACT may result if personnel fail to observe safety precautions. REDUCE OUTPUT(S) to minimum after each step within the performance check where applicable.

- a. Connect TI to 115 V ac power source.
- b. Press **LINE** pushbutton to on and allow at least 30 minutes for TI to warm-up and stabilize.

**NOTE**

- 1. [ ] Denotes softkey on display.
- 2. Refer to C in figure 1 for softkey location.
- 3. [ ] Softkeys and keys will be referred to as keys in this procedure.

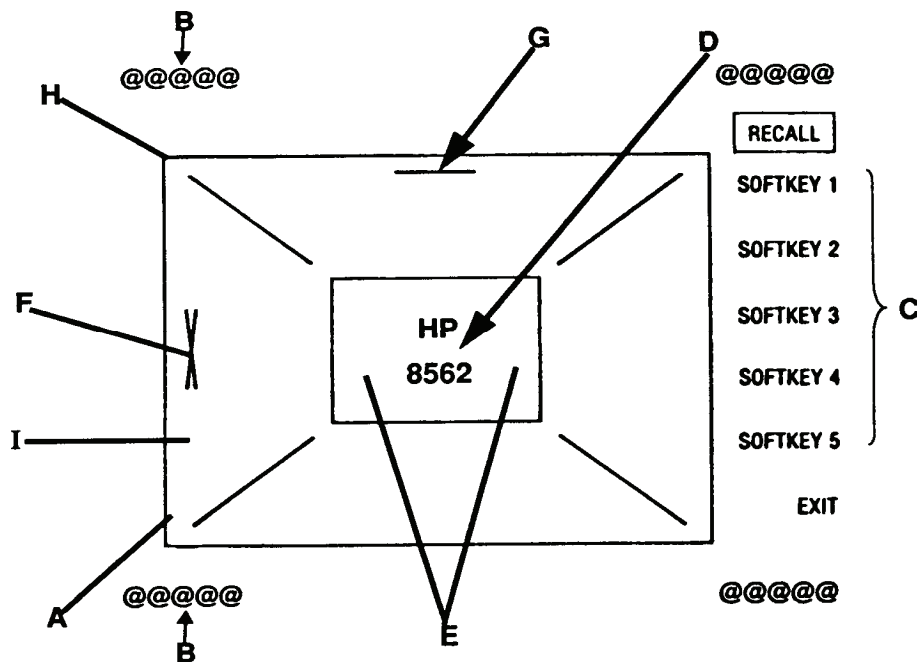

Figure 1. Crt adjustment pattern.

**c.** Press TI keys as listed in (1) through (3) below:

- (1) **INSTRUMENT STATE RECALL.**
- (2) **[MORE].**
- (3) **[CRT ADJ PATTERN].**

**d.** Adjust **TRACE ALIGN** (rear panel) until leftmost line of test pattern A (fig. 1) is parallel with crt bezel.

**e.** Adjust **X POSN** (rear panel) until leftmost @ characters B (fig. 1) and softkey labels C (fig. 1) appear just inside left and right edges of crt bezel.

**f.** Adjust **Y POSN** (rear panel) until the softkey labels C (fig. 1) align with the appropriate softkeys.

**g.** Press **INSTRUMENT STATE PRESET** key.

## **8. Calibrator Output Accuracy Test**

### **a. Performance Check**

#### **NOTE**

Ensure proper calibration factors for sensor module being used are loaded into measuring receiver.

- (1) Connect measuring receiver sensor module input to **TI CAL OUTPUT**.
- (2) Setup measuring receiver to measure frequency. If measuring receiver does not indicate between 299.9988 and 300.0012 MHz, perform **b** (1) below.
- (3) Setup measuring receiver to measure RF power in dBm at 300 MHz. If measuring receiver does not indicate between -9.7 and -10.3 dBm, perform **b** (2) below.
- (4) Disconnect sensor module from TI.
- (5) Connect **TI CAL OUTPUT** to **INPUT 50 Ω**.
- (6) Press TI keys and enter values using the **DATA** keys as listed in (a) through (g) below:
  - (a) **INSTRUMENT STATE PRESET.**
  - (b) **FREQUENCY** then **[CENTER FREQ]** to **300 MHz**.
  - (c) **SPAN** then **[SPAN WIDTH]** to **20 MHz**.
  - (d) **MARKER PEAK SEARCH.**
  - (e) **AMPLITUDE** then **[REF LVL]** to **-10 dBm**.
  - (f) **[MORE].**
  - (g) **[REF LVL CAL].**
- (7) Adjust TI knob until **MKR** indication is between -9.83 and -10.17 dBm.
- (8) Press **[STORE REF LVL]** key.

### **b. Adjustments**

**NOTE**

Allow TI 30 minutes warm-up before performing the adjustment below.

(1) Adjust A15R306 (located on A15 board) for a measuring receiver indication between 299.99997 and 300.00003 MHz.

(2) Adjust A15R561 (located on A15 board) for a measuring receiver indication between -9.95 and -10.05 dBm.

**9. Displayed Average Noise Level Test****a. Performance Check**

- (1) Connect TI **CAL OUTPUT** to **INPUT 50  $\Omega$** .
- (2) Press TI keys and enter values using the **DATA** keys as listed in (a) through (k) below:
  - (a) **INSTRUMENT STATE PRESET**.
  - (b) **FREQUENCY** then [**CENTER FREQ**] to **300 MHz**.
  - (c) **SPAN** then [**SPAN WIDTH**] to **10 kHz**.
  - (d) **AMPLITUDE** then [**REF LVL**] to **-10 dBm**.
  - (e) [**ATTEN**] to **0 dB**.
  - (f) **CONTROL BW** then [**RES BW**] to **100 Hz**.
  - (g) [**VIDEO BW**] to **30 Hz**.
  - (h) **MARKER PEAK SEARCH**.
  - (i) **AMPLITUDE**.
  - (j) [**MORE**].
  - (k) [**REF LVL CAL**].
- (3) Slowly adjust TI knob until **MKR** indication is between -9.83 and -10.17 dBm.
- (4) Disconnect **CAL OUTPUT** from **INPUT 50  $\Omega$**  and connect a 50  $\Omega$  termination to **INPUT 50  $\Omega$** .
- (5) Press TI keys and enter values using **DATA** keys as listed in (a) through (h) below:
  - (a) **AMPLITUDE** then [**REF LVL**] to **-50 dBm**.
  - (b) **SPAN** then [**ZERO SPAN**].
  - (c) **FREQUENCY** then [**CENTER FREQ**] to **10 kHz**.
  - (d) **CONTROL BW** then [**VIDEO BW**] to **1 Hz**.
  - (e) **CONTROL TRIG**.
  - (f) [**SINGLE**].
  - (g) [**SINGLE**] wait for completion of sweep.
  - (h) **MARKER ON**.
- (6) TI **MKR** amplitude indication will be <-90 dBm.
- (7) Press TI **FREQUENCY** key then [**CENTER FREQ**] to **99 kHz**.

- (8) Press TI **CONTROL TRIG** key then [**SINGLE**] key. TI **MKR** amplitude indication will be <-100 dBm.
- (9) Press TI keys and enter values using **DATA** keys as listed in (a) through (e) below:
  - (a) **FREQUENCY** and then [**START FREQ**] to **1 MHz**.
  - (b) [**STOP FREQ**] to **2.9 GHz**.
  - (c) **MARKER OFF**.
  - (d) **CONTROL BW** then [**RES BW**] to **1 MHz**.
  - (e) [**VIDEO BW**] to **10 kHz**.
- (10) Press TI keys as listed in (a) through (d) below:
  - (a) **CONTROL TRIG**.
  - (b) [**SINGLE**] wait for completion of sweep.
  - (c) **MARKER ON**.
  - (d) [**MKRNOISE ON**].
- (11) Adjust TI knob to position marker at the highest average noise level on TI crt.
- (12) Press TI keys and enter values using **DATA** keys as listed in (a) through (h) below:
  - (a) **MARKER MKR**→ then [**MARKER**→ **CF**].
  - (b) **SPAN** then [**ZERO SPAN**].
  - (c) **MARKER OFF**.
  - (d) **CONTROL BW** then [**RES BW**] to **100 Hz**.
  - (e) [**VIDEO BW**] to **1 Hz**.
  - (f) **CONTROL TRIG**.
  - (g) [**SINGLE**] wait for completion of sweep.
  - (h) **MARKER ON**.
- (13) TI **MKR** amplitude indication will be <-121 dBm.
- (14) Press TI keys and enter values using **DATA** keys as listed in (a) through (e) below:
  - (a) **FREQUENCY** then [**START FREQ**] to **2.9 GHz**.
  - (b) [**STOP FREQ**] to **6.46 GHz**.
  - (c) **MARKER OFF**.
  - (d) **CONTROL BW** then [**RES BW**] to **1 MHz**.
  - (e) [**VIDEO BW**] to **10 kHz**.
- (15) Repeat (10) through (12) above. TI **MKR** amplitude indication will be <-121 dBm.
- (16) Press TI keys and enter values using **DATA** keys as listed in (a) through (e) below:
  - (a) **FREQUENCY** then [**START FREQ**] to **6.46 GHz**.
  - (b) [**STOP FREQ**] to **13 GHz**.
  - (c) **MARKER OFF**.
  - (d) **CONTROL BW** then [**RES BW**] to **1 MHz**.



- (e) **[VIDEO BW]** to **10 kHz**.
  - (17) Repeat (10) through (12) above. TI **MKR** amplitude indication will be <-110 dBm.
  - (18) Press TI keys and enter values using **DATA** keys as listed in (a) through (e) below:
    - (a) **FREQUENCY** then **[START FREQ]** to **13 GHz**.
    - (b) **[STOP FREQ]** to **18 GHz**.
    - (c) **MARKER OFF**.
    - (d) **CONTROL BW [RES BW]** to **1 MHz**.
    - (e) **[VIDEO BW]** to **10 kHz**.
  - (19) Repeat (10) through (12) above. TI **MKR** amplitude indication will be <-105 dBm.
- b. Adjustments.** No adjustments can be made.

## 10. Resolution Bandwidth Accuracy and Selectivity Test

### a. Performance Check

- (1) Connect TI **10 MHz REF IN/OUT** to synthesizer/level generator **40/N MHz REF INPUT**.
- (2) Connect synthesizer/level generator **OUTPUT 50  $\Omega$**  to TI **INPUT 50  $\Omega$** .
- (3) Press synthesizer/level generator keys to values as listed in (a) through (c) below:
  - (a) **FREQUENCY** to **40 MHz**.
  - (b) **AMPLITUDE** to **-3 dBm**.
  - (c) **AMPTD INCR** to **1 dB**.
- (4) Press TI keys enter values using **DATA** keys as listed in (a) through (k) below:
  - (a) **INSTRUMENT STATE PRESET**.
  - (b) **AMPLITUDE**.
  - (c) **[MORE]**.
  - (d) **[IF ADJUST]**.
  - (e) **[IF ADJ OFF]**.
  - (f) **FREQUENCY** then **[CENTER FREQ]** to **40 MHz**.
  - (g) **SPAN** then **[ZERO SPAN]**.
  - (h) **AMPLITUDE** then **[LOG dB/DIV]** to **1 dB**.
  - (i) **CONTROL BW** then **[RES BW]** to **2 MHz** (1 MHz for SN prefix below 2805A).
  - (j) **[VIDEO BW]** to **300 Hz**.
  - (k) **CONTROL SWEEP** then **[SWEEP TIME]** to **50 ms**.
- (5) Adjust synthesizer/level generator amplitude to position the signal 2 to 3 divisions (2 to 3 dB) below TI reference level.
- (6) Set synthesizer/level generator **AMPTD INCR** to **3 dB**.
- (7) Press TI keys as listed in (a) through (e) below:

- (a) **AMPLITUDE**.
- (b) **[MORE]**.
- (c) **[IF ADJUST]**.
- (d) **[ADJ CURR IF STATE]** wait for **IF ADJUST STATUS** messages to disappear.
- (e) **SPAN** then **[ZERO SPAN]**.

(8) Press synthesizer/level generator **FREQUENCY** key and adjust frequency to peak signal amplitude on TI.

**NOTE**

At 2 MHz setting, several minor peaks might be observed.  
Select peak with highest amplitude.

- (9) Press synthesizer/level generator **AMPLITUDE** key then **INCR ↓** key.
- (10) Press **TI MARKER ON** key then **[MARKER DELTA]** key.
- (11) Press synthesizer/level generator **INCR ↑** key.
- (12) Press synthesizer/level generator **FREQUENCY** key and increase frequency for a **TI Δ MKR** indication between -0.02 and +0.02 dB. Record synthesizer/level generator frequency indication as upper 3 dB frequency.
- (13) Decrease synthesizer/level generator frequency past TI signal peak amplitude until **Δ MKR** indicates between -0.02 and +0.02 dB. Record synthesizer/level generator frequency indication as lower 3 dB frequency.
- (14) Subtract lower 3 dB frequency recorded in (13) above from upper 3 dB frequency recorded in (12) above. The result will be within the limits specified in table 3. Record the result as actual 3 dB bandwidth in table 3.
- (15) Set synthesizer/level generator frequency to 40 MHz.
- (16) Press **TI MARKER OFF** key.

Table 3. Resolution Bandwidth Accuracy

Test instrument <b>CONTROL BW [RES SW] settings</b>	3 dB bandwidth limits		Actual bandwidth	
	Lower 3 dB frequency Min	Upper 3 dB frequency Max	3dB (14)	60 dB (27)
2 MHz	1.5 MHz	2.5 MHz		
1 MHz	750 kHz	1.25 MHz		
300 kHz	270 kHz	330 kHz		
100 kHz	90 kHz	110 kHz		
30 kHz	27 kHz	33 kHz		
10 kHz <sup>1</sup>	9 kHz	11 kHz		

Table 3. Resolution Bandwidth Accuracy Continued

Test instrument <b>CONTROL BW</b> <b>[RES SW]</b> settings	3 dB bandwidth limits		Actual bandwidth	
	Lower 3 dB frequency Min	Upper 3 dB frequency Max	3dB (14)	60 dB (27)
3 kHz <sup>1</sup>	2.7 kHz	3.3 kHz		
1 kHz <sup>1</sup>	900 Hz	1.1 kHz		
300 Hz <sup>1</sup>	270 Hz	330 Hz		
100 Hz <sup>1</sup>	70 Hz	130 Hz		

<sup>1</sup>Press TI **CONTROL BW** key then **[VIDEO BW]** to 1 Hz.

#### NOTE

The 3 dB bandwidth recorded in table 3 will be used to determine shape factor in (28) below.

(17) Repeat technique of (4) (i) and (7) through (16) above for remaining **CONTROL BW [RES BW]** settings in table 3.

(18) Press TI keys and enter values using **DATA** keys as listed in (a) through (c) below:

- (a) **AMPLITUDE** then **[LOG dB/DIV]** to **10 dB**.
- (b) **CONTROL BW** then **[RES BW]** to **2 MHz** (1 MHz for SN prefix below 2805A).
- (c) **[VIDEO BW]** to **300 Hz**.

(19) Set synthesizer/level generator amplitude to -3 dBm and **AMPTD INCR** to **60 dB**.

(20) Press TI keys as listed in (a) through (d) below:

- (a) **AMPLITUDE**.
- (b) **[MORE]**.
- (c) **[IF ADJUST]**.
- (d) **[ADJ CURR IF STATE]** wait for **IF ADJUST STATUS** messages to disappear.

(21) Press synthesizer/level generator **FREQUENCY** key and adjust frequency to peak signal amplitude on TI display.

#### NOTE

At 2 MHz setting, several minor peaks might be observed.  
Select peak with highest amplitude.

(22) Press synthesizer/level generator **AMPLITUDE** key then **INCR ↓** key.

(23) Press TI **MARKER ON** key then **[MARKER DELTA]** key.

(24) Press synthesizer/level generator **INCR ↑** key.

(25) Press synthesizer/level generator **FREQUENCY** key and increase frequency for a TI **Δ MKR** indication between -0.02 and +0.02 dB. Record synthesizer/level generator frequency indication as upper 60 dB frequency.

(26) Decrease synthesizer/level generator frequency past TI signal amplitude peak amplitude until **Δ MKR** indicates between -0.02 and +0.02 dB. Record synthesizer/level generator frequency as lower 60 dB frequency.

(27) Subtract lower 60 dB frequency recorded in (26) above from upper 60 dB frequency recorded in (25) above. Record the result as actual 60 dB bandwidth in table 3.

(28) Divide the 60 dB bandwidth recorded in (27) above by the 3 dB bandwidth recorded in table 3 above. The result must be a shape factor of 15 or less.

(29) Set synthesizer/level generator frequency to 40 MHz.

(30) Press **TI MARKER OFF** key.

(31) Repeat technique of (18) (b) and (20) through (30) above for remaining **CONTROL BW [RES BW]** settings listed in table 3.

**b. Adjustments.** No adjustments can be made.

## 11. Input Attenuator Accuracy

### a. Performance Check

(1) Connect equipment as shown in figure 2.

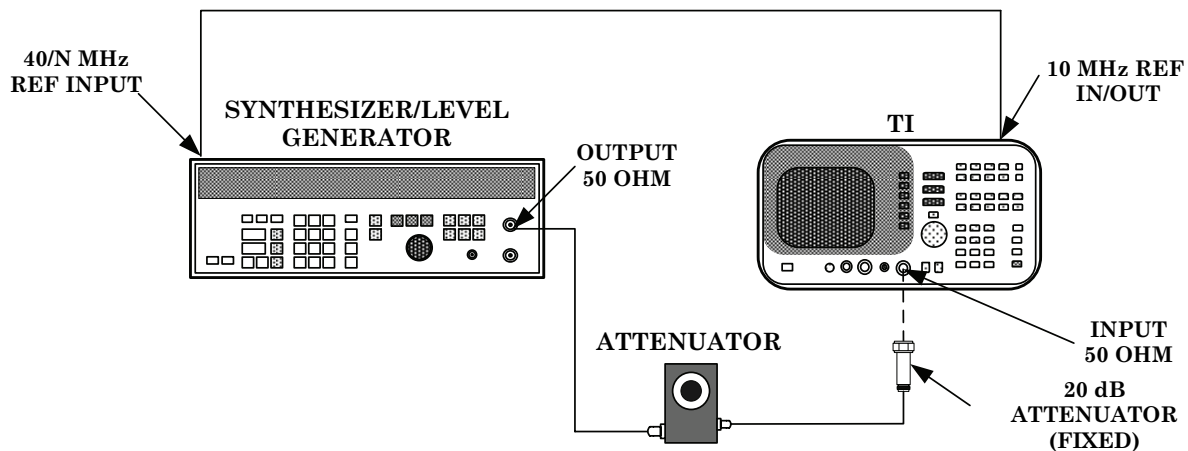

Figure 2. Input attenuator accuracy (50 MHz) - equipment setup.

(2) Press synthesizer/level generator keys to values as listed in (a) through (c) below:

(a) **FREQUENCY** to **50 MHz**.

(b) **AMPLITUDE** to **-50 dBm**.

(c) **AMPTD INCR** to **10 dB**.

(3) Press TI keys and enter values using **DATA** keys as listed in (a) through (k) below:

(a) **INSTRUMENT STATE PRESET**.

(b) **[REALIGN LO & IF]** wait for **ADJUST STATUS** messages to disappear.

(c) **INSTRUMENT STATE RECALL**.

(d) **[MORE]**.

(e) **[FACTORY PRSEL PK]**.

(f) **FREQUENCY** then **[CENTER FREQ]** to **50 MHz**.

(g) **SPAN** then **[ZERO SPAN]**.

- (h) **AMPLITUDE** then **[REF LVL]** to **-70 dBm**.
  - (i) **[LOG dB/DIV]** to **1 dB**.
  - (j) **CONTROL BW** then **[RES BW]** to **3 kHz**.
  - (k) **[VIDEO BW]** to **1 Hz**.
- (4) Set attenuator to 0 dB.

**NOTE**

Attenuator (fixed) listed in table 2 may be substituted in equipment setup as necessary to obtain TI reference level in (5) below.

- (5) Adjust attenuator to position signal peak 2 to 3 divisions below TI reference level.
- (6) Press TI keys as listed in (a) through (e) below:
  - (a) **CONTROL TRIG**.
  - (b) **[SINGLE]**.
  - (c) **[SINGLE]**.
  - (d) **MARKER ON**.
  - (e) **[MARKER DELTA]**.
- (7) Press synthesizer/level generator **AMPLITUDE** key.
- (8) Press synthesizer/level generator **INCR ↑** key.
- (9) Press TI **AMPLITUDE** key then **[REF LVL]** to **-60 dBm** and **[ATTEN]** to **20 dB**.
- (10) Press TI **CONTROL TRIG** key then **[SINGLE]** key and wait for completion of sweep. TI **Δ MKR** indication will be within limits specified in table 4. Record **Δ MKR** indication as actual **Δ MKR** indication in table 4.

Table 4. Input Attenuator Accuracy

Synthesizer/level generator amplitude settings (dBm)	Test instrument				
	[REF LVL] settings (dBm)	[ATTEN] settings (dB)	Δ MKR indications (dB)		
			Min	Max	Actual
-40	-60	20	+8.2	+11.8	
-30	-50	30	+18.2	+21.8	
-20	-40	40	+28.2	+31.8	
-10	-30	50	+38.2	+41.8	
0	-20	60	+48.2	+51.8	
+10	-10	70	+58.2	+61.8	

- (11) Repeat (8) through (10) above for remaining synthesizer/level generator amplitude, TI **[REF LVL]** and **[ATTEN]** settings listed in table 4.
- (12) Calculate the step-to-step accuracy for TI **[ATTEN]** 20 dB setting by subtracting 10 dB from the actual **Δ MKR** indication recorded in table 4 for **[ATTEN]** 20 dB setting. Difference will be between -0.6 and +0.6 dB.
- (13) Calculate the step-to-step accuracy for TI **[ATTEN]** 30, 40, 50, 60 and 70 dB settings by subtracting previous **[ATTEN]** setting actual **Δ MKR** indication recorded in

table 4 from the current [ATTEN] setting actual  $\Delta$  MKR indication recorded in table 4 and then subtract 10 dB from the results. Difference will be between -0.6 and +0.6 dB for each setting.

EXAMPLE:

$$30 \text{ dB step-to-step accuracy} = \begin{matrix} \text{(Current)} \\ \text{TI [ATTEN] 30 dB} \\ \text{(actual } \Delta \text{ MKR indication)} \end{matrix} - \begin{matrix} \text{(Previous)} \\ \text{TI [ATTEN] 20 dB} \\ \text{actual } \Delta \text{ MKR indication} \end{matrix} - 10 \text{ dB}$$

b. **Adjustments.** No adjustments can be made.

## 12. IF Gain Uncertainty

### a. Performance Check

(1) Connect equipment as shown in figure 3.

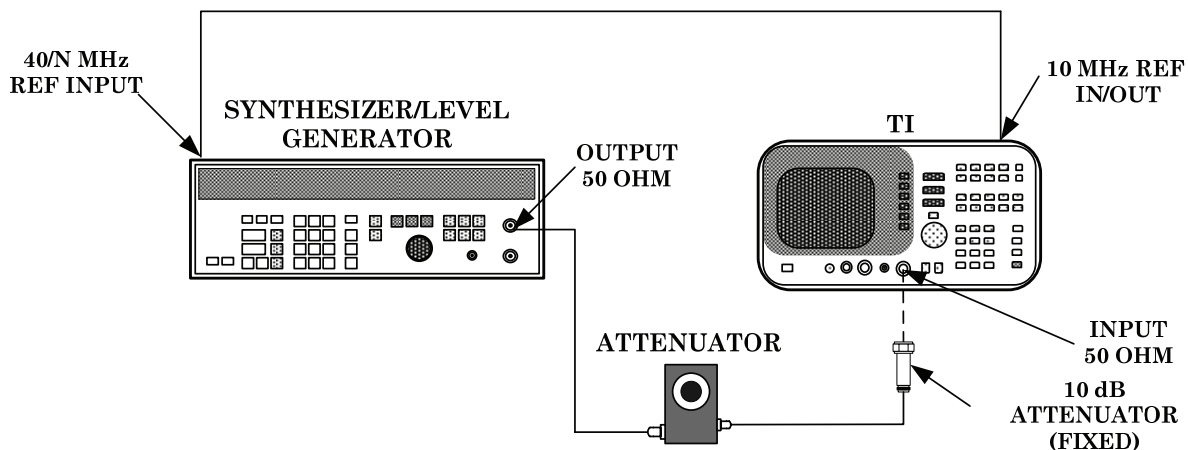

Figure 3. IF gain uncertainty - equipment setup.

- (2) Press synthesizer/level generator keys to values listed in (a) through (c) below:
  - (a) **FREQUENCY** to **50 MHz**.
  - (b) **AMPLITUDE** to **+10 dBm**.
  - (c) **AMPTD INCR** to **10 dB**.
- (3) Press TI keys and enter values using **DATA** keys as listed in (a) through (g) below:
  - (a) **INSTRUMENT STATE PRESET**.
  - (b) **[REALIGN LO & IF]** wait for **ADJUST STATUS** messages to disappear.
  - (c) **FREQUENCY** then **[CENTER FREQ]** to **50 MHz**.
  - (d) **SPAN** then **[ZERO SPAN]**.
  - (e) **AMPLITUDE** then **[LOG dB/DIV]** to **1 dB**.
  - (f) **CONTROL BW** then **[RES BW]** to **10 kHz**.
  - (g) **[VIDEO BW]** to **1 Hz**.

- (4) Set attenuator to 0 dB.
- (5) Press TI **MARKER ON** key.

**NOTE**

Attenuator (fixed) listed in table 2 may be substituted in equipment setup as necessary to obtain TI reference level in (6), (16), and (26) below.

- (6) Adjust attenuator to position signal peak 2 to 3 dB (2 to 3 divisions) below TI reference level.
- (7) Press TI keys as listed in (a) through (e) below:
  - (a) **CONTROL TRIG**.
  - (b) **[SINGLE]**.
  - (c) **[SINGLE]**.
  - (d) **MARKER ON**.
  - (e) **[MARKER DELTA]**.
- (8) Press synthesizer/level generator **AMPLITUDE** key.
- (9) Press synthesizer/level generator **INCR ↓** key.
- (10) Press TI **AMPLITUDE** then **[REF LVL]** to **-10 dBm**.
- (11) Press TI **CONTROL TRIG** key then **[SINGLE]** key and wait for completion of sweep.
- (12) TI **Δ MKR** indication will be between **-9** and **-11 dB**.
- (13) Repeat technique of (9) through (11) above for synthesizer/level generator amplitude and TI **AMPLITUDE [REF LVL]** settings listed in table 5. TI **Δ MKR** indications will be within limits specified in table 5.

Table 5. Log Gain Uncertainty (10 dB Steps)

Synthesizer/level generator amplitude settings (dBm)	Test instrument		
	AMPLITUDE [REF LVL] settings (dBm)	Δ MKR indications (dB)	
		Min	Max
-10	-20	-21	-19
-20	-30	-31	-29
-30	-40	-41	-39
-40	-50	-51	-49
-50	-60	-61	-59
-60	-70	-71	-69
-70	-80	-81	-79

- (14) Set synthesizer/level generator amplitude to +10 dBm and **AMPTD INCR** to **1 dB**.
- (15) Press TI keys and enter values using **DATA** keys as listed in (a) though (c) below:
  - (a) **MARKER MKR→** then **[MARKER NORMAL]**.
  - (b) **AMPLITUDE** then **[REF LVL]** to **0 dBm**.
  - (c) **CONTROL TRIG** then **[CONT]**.

(16) Adjust attenuator to position signal peak 2 to 3 dB (2 to 3 divisions) below TI reference level.

(17) Press TI keys as listed in (a) through (e) below:

- (a) **CONTROL TRIG.**
- (b) **[SINGLE].**
- (c) **[SINGLE].**
- (d) **MARKER ON.**
- (e) **[MARKER DELTA].**

(18) Press synthesizer/level generator **AMPLITUDE** key.

(19) Press synthesizer/level generator **INCR ↓** key.

(20) Press TI **AMPLITUDE** key then **[REF LVL]** to **-1 dBm.**

(21) Press TI **CONTROL TRIG** key then **[SINGLE]** key and wait for completion of sweep.

(22) TI **Δ MKR** indication will be between 0 and -2 dB.

(23) Repeat technique of (19) through (21) above for synthesizer/level generator amplitude and TI **AMPLITUDE [REF LVL]** settings listed in table 6. TI **Δ MKR** indications will be within limits specified in table 6.

Table 6. Log Gain Uncertainty (1 dB Steps)

Synthesizer/level generator amplitude settings (dBm)	Test instrument		
	AMPLITUDE [REF LVL] settings (dBm)	Δ MKR indications (dB)	
		Min	Max
+8	-2	-3	-1
+7	-3	-4	-2
+6	-4	-5	-3
+5	-5	-6	-4
+4	-6	-7	-5
+3	-7	-8	-6
+2	-8	-9	-7
+1	-9	-10	-8
0	-10	-11	-9
-1	-11	-12	-10
-2	-12	-13	-11

(24) Set synthesizer/level generator amplitude to +10 dBm and **AMPTD INCR** to **10 dB.**

(25) Press TI keys to values using **DATA** keys as listed in (a) through (e) below:

- (a) **MARKER MKR→** then **[MARKER NORMAL].**
- (b) **AMPLITUDE** then **[REF LVL]** to **0 dBm.**
- (c) **[LINEAR]** then **[MORE].**
- (d) **[UNITS]** then **[dBm].**
- (e) **CONTROL TRIG** then **[CONT].**



(26) Adjust attenuator to position signal peak 2 to 3 dB (2 to 3 divisions) below TI reference level.

(27) Press TI keys as listed in (a) through (e) below:

- (a) **CONTROL TRIG.**
- (b) **[SINGLE].**
- (c) **[SINGLE].**
- (d) **MARKER ON.**
- (e) **[MARKER DELTA].**

(28) Press synthesizer/level generator **AMPLITUDE** key.

(29) Press synthesizer/level generator **INCR** ↓ key.

(30) Press TI **AMPLITUDE** key then **[REF LVL]** to **-10 dBm**.

(31) Press TI **CONTROL TRIG** key then **[SINGLE]** key and wait for completion of sweep.

(32) TI **Δ MKR** indication will be between -9 and -11 dB.

(33) Repeat technique of (29) through (31) above for synthesizer/level generator and TI **AMPLITUDE [REF LVL]** settings listed in table 7. TI **Δ MKR** indications will be within limits specified in table 7.

Table 7. Linear IF Gain Uncertainty

Synthesizer/level generator amplitude settings (dBm)	Test instrument		
	AMPLITUDE [REF LVL] settings (dBm)	ΔMKR indications (dB)	
		Min	Max
-10	-20	-21	-19
-20	-30	-31	-29
-30	-40	-41	-39
-40	-50	-51	-49
-50	-60	-61	-59
-60	-70	-71	-69
-70	-80	-81	-79

**b. Adjustments.** Refer to paragraph 1 a.

### 13. Residual FM

#### a. Performance Check

- (1) Connect synthesized signal generator **RF Output** to TI **INPUT 50 Ω**.
- (2) Set synthesized signal generator frequency to 2.5 GHz and level output to -10 dBm.
- (3) Press TI keys and enter values using **DATA** keys listed in (a) through (v) below:
  - (a) **INSTRUMENT STATE PRESET.**
  - (b) **FREQUENCY** then **[CENTER FREQ]** to **2.5 GHz**.
  - (c) **SPAN** then **[SPAN WIDTH]** to **1 MHz**.
  - (d) **AMPLITUDE** then **[REF LEVEL]** to **-5 dBm**.

- (e) **[LOG dB/DIV]** to 1 dB.
- (f) **CONTROL BW** then **[RES BW]** to 3 kHz.
- (g) **MARKER PEAK SEARCH**.
- (h) **[SIG TRK ON]**.
- (i) **SPAN** then **[SPAN WIDTH]** to 10 kHz.
- (j) **CONTROL BW** then **[RES BW]** to 1 kHz.
- (k) **MARKER ON**.
- (l) **[SIG TRK OFF]**.
- (m) **MARKER PEAK SEARCH**.
- (n) **MARKER MKR→**.
- (o) **[MARKER→ CF]**.
- (p) **[MARKER→ REF LVL]**.
- (q) **MARKER OFF**.
- (r) **CONTROL TRIG**.
- (s) **[SINGLE]**.
- (t) **[SINGLE]** wait for completion of sweep.
- (u) **MARKER PEAK SEARCH**.
- (v) **[MARKER DELTA]**.

- (4) Adjust TI knob ccw for a  $\Delta$  **MKR** indication between -0.9 and -1.1 dB and press **[MARKER DELTA]** key.
- (5) Adjust TI knob ccw for a  $\Delta$  **MKR** indication between -3.9 and -4.1 dB.
- (6) Divide  $\Delta$  **MKR** frequency (in Hz) by  $\Delta$  **MKR** amplitude (in dB) to obtain slope of **[RES BW]** filter and record result.

EXAMPLE: If  $\Delta$  **MKR** frequency is 380 Hz and  $\Delta$  **MKR** amplitude is 3.92 dB then slope would be:  $380 \text{ Hz} \div 3.92 \text{ dB} = 96.94 \text{ Hz/dB}$ .

- (7) Press TI keys as listed in (a) through (c) below:
  - (a) **MARKER OFF**.
  - (b) **MARKER PEAK SEARCH**.
  - (c) **[MARKER DELTA]**.
- (8) Adjust TI knob ccw for a  $\Delta$  **MKR** indication between -2.9 and -3.1 dB.
- (9) Press TI keys and enter values using **DATA** keys as listed in (a) through (g) below:
  - (a) **MARKER MKR→**.
  - (b) **[MARKER NORMAL]**.
  - (c) **[MARKER→ CF]**.
  - (d) **SPAN** then **[ZERO SPAN]**.
  - (e) **CONTROL SWEEP** then **[SWEEP TIME]** to 100 ms.

- (f) **CONTROL TRIG.**
- (g) **[SINGLE].**

#### **NOTE**

If displayed trace is not approximately 3 divisions below the reference level, press **[CONT]** key and then **FREQUENCY** key. Adjust displayed trace approximately 3 divisions below reference level with TI knob.

- (10) Press **CONTROL TRIG** key then **[SINGLE]** key.
- (11) Press **MARKER ON** key and adjust TI knob to position marker on horizontal division with greatest amplitude deviation.
- (12) Press **[MARKER DELTA]** key and adjust TI knob to position marker at lowest amplitude in the same horizontal division. Record absolute value of  $\Delta$  **MKR** amplitude indication.
- (13) Multiply value recorded in (6) above by value recorded in (12) above. Result will be less than 50 Hz.

**b. Adjustments.** No adjustments can be made.

### **14. Frequency Readout and Frequency Count Marker Accuracy**

#### **a. Performance Check**

- (1) Connect TI **10 MHz REF IN/OUT** to synthesized signal generator **10 MHz REF IN**.
- (2) Connect synthesized signal generator **RF Output** to TI **INPUT 50  $\Omega$** .
- (3) Set synthesized signal generator frequency to 1.5 GHz and level output to -10 dBm.
- (4) Press TI keys and enter values using **DATA** keys as listed in (a) through (f) below:
  - (a) **INSTRUMENT STATE PRESET.**
  - (b) **FREQUENCY** then **[CENTER FREQ]** to **1.5 GHz**.
  - (c) **SPAN** then **[SPAN WIDTH]** to **1 MHz**.
  - (d) **INSTRUMENT STATE RECALL.**
  - (e) **[MORE].**
  - (f) **[FACTORY PRSEL PK].**
- (5) Press TI **MARKER PEAK SEARCH** key. TI **MKR** frequency indication will be between 1.499948 and 1.500051 GHz.
- (6) Repeat technique of (4) (c) and (5) above for remaining TI **SPAN [SPAN WIDTH]** settings listed in table 8. TI **MKR** frequency indications will be within the limits specified in table 8.

Table 8. Frequency Readout Accuracy – 1.5 GHz

Synthesized signal generator frequency setting (GHz)	Test instrument			
	FREQUENCY [CENTER FREQ] setting (GHz)	SPAN [SPAN WIDTH] settings	MKR frequency indications (GHz)	
			Min	Max
1.5	1.5	10 MHz	1.49948	1.50051
1.5	1.5	20 MHz	1.49895	1.50104
1.5	1.5	50 MHz	1.49745	1.50254
1.5	1.5	100 MHz	1.4948	1.5052
1.5	1.5	1 GHz	1.450	1.550

- (7) Set synthesized signal generator frequency to 4 GHz.
- (8) Press TI keys and enter values using **DATA** keys as listed in (a) through (e) below:
  - (a) **FREQUENCY** then **[CENTER FREQ]** to **4 GHz**.
  - (b) **MARKER PEAK SEARCH**.
  - (c) **INSTRUMENT STATE MIXER INT**.
  - (d) **[PRESEL AUTO PK]** wait for **PEAKING** message to disappear.
  - (e) **SPAN** then **[SPAN WIDTH]** to **1 MHz**.
- (9) Press TI **MARKER PEAK SEARCH** key. TI **MKR** frequency indication will be between 3.999948 and 4.000051 GHz.
- (10) Press TI **SPAN** key then **[SPAN WIDTH]** to **10 MHz**.
- (11) Press TI **MARKER PEAK SEARCH** key. TI **MKR** frequency indication will be between 3.99948 and 4.00051 GHz.
- (12) Repeat technique of (10) and (11) above for remaining **SPAN [SPAN WIDTH]** settings listed in table 9. TI **MKR** frequency indications will be within limits specified in table 9.

Table 9. Frequency Readout Accuracy – 4 GHz

Synthesized signal generator frequency setting (GHz)	Test instrument			
	FREQUENCY [CENTER FREQ] setting (GHz)	SPAN [SPAN WIDTH] settings	MKR frequency indications (GHz)	
			Min	Max
4	4	20 MHz	3.99895	4.00104
4	4	50 MHz	3.99745	4.00254
4	4	100 MHz	3.9948	4.0051
4	4	1 GHz	3.950	4.050

- (13) Set synthesized signal generator frequency to 9 GHz.
- (14) Press TI keys and enter values using **DATA** keys as listed in (a) through (e) below:
  - (a) **FREQUENCY** then **[CENTER FREQ]** to **9 GHz**.
  - (b) **MARKER PEAK SEARCH**.
  - (c) **INSTRUMENT STATE MIXER INT**.
  - (d) **[PRESEL AUTO PK]** wait for **PEAKING** message to disappear.
  - (e) **SPAN** then **[SPAN WIDTH]** to **1 MHz**.

(15) Press **TI MARKER PEAK SEARCH** key. **TI MKR** frequency indication will be between 8.999948 and 9.000051 GHz.

(16) Press **TI SPAN** key then **[SPAN WIDTH]** to **10 MHz**.

(17) Press **TI MARKER PEAK SEARCH** key. **TI MKR** frequency indication will be between 8.99948 and 9.00051 GHz.

(18) Repeat technique of (16) and (17) above for remaining **SPAN [SPAN WIDTH]** settings listed in table 10. **TI MKR** frequency indications will be within limits specified in table 10.

Table 10. Frequency Readout Accuracy – 9 GHz

Synthesized signal generator frequency setting (GHz)	Test instrument			
	<b>FREQUENCY [CENTER FREQ]</b> setting (GHz)	<b>SPAN [SPAN WIDTH]</b> settings	<b>MKR frequency indications (GHz)</b>	
			Min	Max
9	9	20 MHz	8.99895	9.00104
9	9	50 MHz	8.99745	9.00254
9	9	100 MHz	8.9948	9.0051
9	9	1 GHz	8.950	9.050

(19) Set synthesized signal generator frequency to 16 GHz.

(20) Press **TI** keys and enter values using **DATA** keys as listed in (a) through (e) below:

(a) **FREQUENCY** then **[CENTER FREQ]** to **16 GHz**.

(b) **MARKER PEAK SEARCH**.

(c) **INSTRUMENT STATE MIXER INT**.

(d) **[PRESEL AUTO PK]** wait for **PEAKING** message to disappear.

(e) **SPAN** then **[SPAN WIDTH]** to **1 MHz**.

(21) Press **TI MARKER PEAK SEARCH** key. **TI MKR** frequency indication will be between 15.999948 and 16.000051 GHz.

(22) Press **TI SPAN** key then **[SPAN WIDTH]** to **10 MHz**.

(23) Press **TI MARKER PEAK SEARCH** key. **TI MKR** frequency indication will be between 15.99948 and 16.00051 GHz.

(24) Repeat technique of (22) and (23) above for remaining **SPAN [SPAN WIDTH]** settings listed in table 11. **TI MKR** frequency indications will be within limits specified in table 11.

Table 11. Frequency Readout Accuracy – 16 GHz

Synthesized signal generator frequency setting (GHz)	Test instrument			
	<b>FREQUENCY [CENTER FREQ]</b> setting (GHz)	<b>SPAN [SPAN WIDTH]</b> settings	<b>MKR frequency indications (GHz)</b>	
			Min	Max
16	16	20 MHz	15.99895	16.00104
16	16	50 MHz	15.99745	16.00254
16	16	100 MHz	15.9948	16.0051
16	16	1 GHz	15.950	16.050

- (25) Set synthesized signal generator frequency to 1.5 GHz.
- (26) Press TI keys and enter values using **DATA** keys as listed in (a) through (c) below:
  - (a) **FREQUENCY** then [**CENTER FREQ**] to **1.5 GHz**.
  - (b) **SPAN** then [**SPAN WIDTH**] to **1 MHz**.
  - (c) **INSTRUMENT STATE FREQ COUNT** then [**COUNTER RES**] to **10 Hz**.
- (27) Press **MARKER PEAK SEARCH** key. TI **MKR** frequency indication will be between 1.49999994 and 1.50000006 GHz.
- (28) Repeat technique of (25) through (27) above for synthesized signal generator and TI [**CENTER FREQ**] settings listed in table 12. TI **MKR** frequency indication will be within limits specified in table 12.

Table 12. Frequency Count Marker Accuracy

Synthesized signal generator frequency settings (GHz)	Test instrument [ <b>CENTER FREQ</b> ] settings (GHz)	Test instrument <b>MKR</b> frequency indications (GHz)	
		Min	Max
4	4	3.99999994	4.00000006
9	9	8.99999989	9.00000011
16	16	15.99999984	16.00000016

**b. Adjustments.** Refer to paragraph 1 a.

**15. Frequency Span Accuracy**

**a. Performance Check**

- (1) Connect TI **10 MHz REF IN/OUT** to synthesized signal generator **10 MHz REF IN**.
- (2) Connect synthesized signal generator **RF Output** to TI **INPUT 50 Ω**.
- (3) Press TI keys as listed in (a) through (d) below:
  - (a) **INSTRUMENT STATE PRESET**.
  - (b) **INSTRUMENT STATE RECALL**.
  - (c) [**MORE**].
  - (d) [**FACTORY PRSEL PK**].
- (4) Press TI **FREQUENCY** key then [**CENTER FREQ**] to **1.5 GHz**.
- (5) Press TI **SPAN** key then [**SPAN WIDTH**] to **10 kHz**.
- (6) Set synthesized signal generator frequency to 1.499996 GHz and level output to -10 dBm.
- (7) Press TI keys as listed in (a) through (e) below:
  - (a) **MARKER OFF**.
  - (b) **CONTROL TRIG**.
  - (c) [**SINGLE**] wait for completion of sweep.

- (d) **MARKER PEAK SEARCH.**
- (e) **[MARKER DELTA].**
- (8) Set synthesized signal generator frequency to 1.500004 GHz.
- (9) Press TI keys as listed in (a) through (c) below:
  - (a) **CONTROL TRIG.**
  - (b) **[SINGLE]** wait for completion of sweep.
  - (c) **MARKER PEAK SEARCH.**
- (10) TI  $\Delta$  MKR indication will be between 7.6 and 8.4 kHz.
- (11) Repeat technique of (5) through (9) above for TI SPAN [SPAN WIDTH] and synthesized signal generator frequency settings listed in table 13. TI  $\Delta$  MKR indications will be within limits specified in table 13.

Table 13. Frequency Span Accuracy – 1.5 GHz Center Frequency

Test instrument		Synthesized signal generator		Test instrument	
FREQUENCY [CENTER FREQ] settings	SPAN [SPAN WIDTH] settings	Frequency (GHz) settings in (6) above	Frequency (GHz) settings in (8) above	$\Delta$ MKR indications	
				Min	Max
1.5	20 kHz	1.499992	1.500008	15.2 kHz	16.8 kHz
1.5	50 kHz	1.49998	1.50002	38.0 kHz	42.0 kHz
1.5	100 kHz	1.49996	1.50004	76.0 kHz	84.0 kHz
1.5	101 kHz	1.49996	1.50004	76.0 kHz	84.0 kHz
1.5	200 kHz	1.49992	1.50008	152 kHz	168.0 kHz
1.5	500 kHz	1.4998	1.5002	380 kHz	420 kHz
1.5	1 MHz	1.4996	1.5004	760 kHz	840 kHz
1.5	1.01 MHz	1.4996	1.5004	760 kHz	840 kHz
1.5	2 MHz	1.4992	1.5008	1.52 MHz	1.68 MHz
1.5	5 MHz	1.498	1.502	3.80 MHz	4.20 MHz
1.5	10 MHz	1.496	1.504	7.60 MHz	8.40 MHz
1.5	20 MHz	1.492	1.508	15.2 MHz	16.8 MHz
1.5	50 MHz	1.48	1.52	38.0 MHz	42.0 MHz
1.5	100 MHz	1.46	1.54	76.0 MHz	84.0 MHz
1.5	200 MHz	1.42	1.58	152 kHz	168.0 MHz
1.5	500 MHz	1.3	1.7	380.0 MHz	420.0 MHz
1.5	1 GHz	1.1	1.9	760.0 MHz	840.0 MHz
1.5	2 GHz	0.7	2.3	1.52 GHz	1.68 GHz

- (12) Press TI **FREQUENCY** key then **[CENTER FREQ]** to **9 GHz**.
- (13) Set synthesized signal generator frequency to 9 GHz.
- (14) Press TI keys as listed in (a) through (g) below:
  - (a) **MARKER OFF.**
  - (b) **CONTROL TRIG.**
  - (c) **[CONT].**
  - (d) **MARKER PEAK SEARCH.**

- (e) **INSTRUMENT STATE MIXER INT.**
  - (f) **[PRESEL AUTO PK]** wait for **PEAKING** message to disappear.
  - (g) **SPAN** then **[SPAN WIDTH]** to **10 kHz**.
- (15) Set synthesized signal generator frequency to 8.999996 GHz.
- (16) Press TI keys as listed in (a) through (e) below:
- (a) **MARKER OFF.**
  - (b) **CONTROL TRIG.**
  - (c) **[SINGLE]** wait for completion of sweep.
  - (d) **MARKER PEAK SEARCH.**
  - (e) **[MARKER DELTA].**
- (17) Set synthesized signal generator frequency to 9.000004 GHz.
- (18) Press TI keys as listed in (a) through (c) below:
- (a) **CONTROL TRIG.**
  - (b) **[SINGLE]** wait for completion of sweep.
  - (c) **MARKER PEAK SEARCH.**
- (19) TI  $\Delta$  **MKR** indication will be between 7.6 and 8.4 kHz.
- (20) Press TI **SPAN** key then **[SPAN WIDTH]** to **20 MHz**.
- (21) Set synthesized signal generator frequency to 8.992 GHz.
- (22) Press TI keys as listed in (a) through (e) below:
- (a) **MARKER OFF.**
  - (b) **CONTROL TRIG.**
  - (c) **[SINGLE].**
  - (d) **MARKER PEAK SEARCH.**
  - (e) **[MARKER DELTA].**
- (23) Set synthesized signal generator frequency to 9.008 GHz.
- (24) Press TI keys as listed in (a) through (c) below:
- (a) **CONTROL TRIG.**
  - (b) **[SINGLE].**
  - (c) **MARKER PEAK SEARCH.**
- (25) TI  $\Delta$  **MKR** indication will be between 15.2 and 16.8 MHz.
- (26) Press TI **SPAN** key then **[SPAN WIDTH]** to **50 MHz**.
- (27) Set synthesized signal generator frequency to 8.98 GHz.
- (28) Press TI keys as listed in (a) through (e) below:
- (a) **MARKER OFF.**
  - (b) **CONTROL TRIG.**



- (c) **[SINGLE]**.
  - (d) **MARKER PEAK SEARCH**.
  - (e) **[MARKER DELTA]**.
- (29) Set synthesized signal generator frequency to 9.02 GHz.
- (30) Press TI keys as listed in (a) through (c) below:
- (a) **CONTROL TRIG**.
  - (b) **[SINGLE]**.
  - (c) **MARKER PEAK SEARCH**.
- (31) TI  $\Delta$  MKR indication will be between 38 and 42 MHz.
- (32) Press TI SPAN key then **[SPAN WIDTH]** to **5 GHz**.
- (33) Set synthesized signal generator frequency to 7 GHz.
- (34) Press TI keys as listed in (a) through (e) below:
- (a) **MARKER OFF**.
  - (b) **CONTROL TRIG**.
  - (c) **[SINGLE]**.
  - (d) **MARKER PEAK SEARCH**.
  - (e) **[MARKER DELTA]**.
- (35) Set synthesized signal generator frequency to 11 GHz.
- (36) Press TI keys as listed in (a) through (c) below:
- (a) **CONTROL TRIG**.
  - (b) **[SINGLE]**.
  - (c) **MARKER PEAK SEARCH**.
- (37) TI  $\Delta$  MKR indication will be between 3.8 and 4.2 GHz.
- (38) Press TI **FREQUENCY** key then **[CENTER FREQ]** to **16 GHz**.
- (39) Set synthesized signal generator frequency to 16 GHz.
- (40) Press TI keys as listed in (a) through (g) below:
- (a) **MARKER OFF**.
  - (b) **CONTROL TRIG**.
  - (c) **[CONT]**.
  - (d) **MARKER PEAK SEARCH**.
  - (e) **INSTRUMENT STATE MIXER INT**.
  - (f) **[PRESEL AUTO PK]** wait for **PEAKING** message to disappear.
  - (g) **SPAN** then **[SPAN WIDTH]** to **10 kHz**.
- (41) Set synthesized signal generator frequency to 15.999996 GHz.
- (42) Press TI keys as listed in (a) through (e) below:

- (a) **MARKER OFF.**
  - (b) **CONTROL TRIG.**
  - (c) **[SINGLE]** wait for completion of sweep.
  - (d) **MARKER PEAK SEARCH.**
  - (e) **[MARKER DELTA].**
- (43) Set synthesized signal generator frequency to 16.000004 GHz.
- (44) Press TI keys as listed in (a) through (c) below:
- (a) **CONTROL TRIG.**
  - (b) **[SINGLE]** wait for completion of sweep.
  - (c) **MARKER PEAK SEARCH.**
- (45) TI  $\Delta$  **MKR** indication will be between 7.6 and 8.4 kHz.
- (46) Press TI **SPAN** key then **[SPAN WIDTH]** to **50 MHz**.
- (47) Set synthesized signal generator frequency to 15.98 GHz.
- (48) Press TI keys as listed in (a) through (e) below:
- (a) **MARKER OFF.**
  - (b) **CONTROL TRIG.**
  - (c) **[SINGLE].**
  - (d) **MARKER PEAK SEARCH.**
  - (e) **[MARKER DELTA].**
- (49) Set synthesized signal generator frequency to 16.02 GHz.
- (50) Press TI keys as listed in (a) through (c) below:
- (a) **CONTROL TRIG.**
  - (b) **[SINGLE].**
  - (c) **MARKER PEAK SEARCH.**
- (51) TI  $\Delta$  **MKR** indication will be between 38 and 42 MHz.
- (52) Press TI **SPAN** key then **[SPAN WIDTH]** to **5 GHz**.
- (53) Set synthesized signal generator frequency to 14 GHz.
- (54) Press TI keys as listed in (a) through (e) below:
- (a) **MARKER OFF.**
  - (b) **CONTROL TRIG.**
  - (c) **[SINGLE].**
  - (d) **MARKER PEAK SEARCH.**
  - (e) **[MARKER DELTA].**
- (55) Set synthesized signal generator frequency to 18 GHz.
- (56) Press TI keys as listed in (a) through (c) below:

- (a) **CONTROL TRIG.**
- (b) **[SINGLE].**
- (c) **MARKER PEAK SEARCH.**

(57) TI  $\Delta$  MKR indication will be between 3.8 and 4.2 GHz.

b. **Adjustments.** Refer to paragraph 1 a.

## 16. Frequency Response

### a. Performance Check

#### NOTE

Ensure proper calibration factors for sensor module being used are loaded into measuring receiver.

- (1) Connect equipment as shown in figure 4.

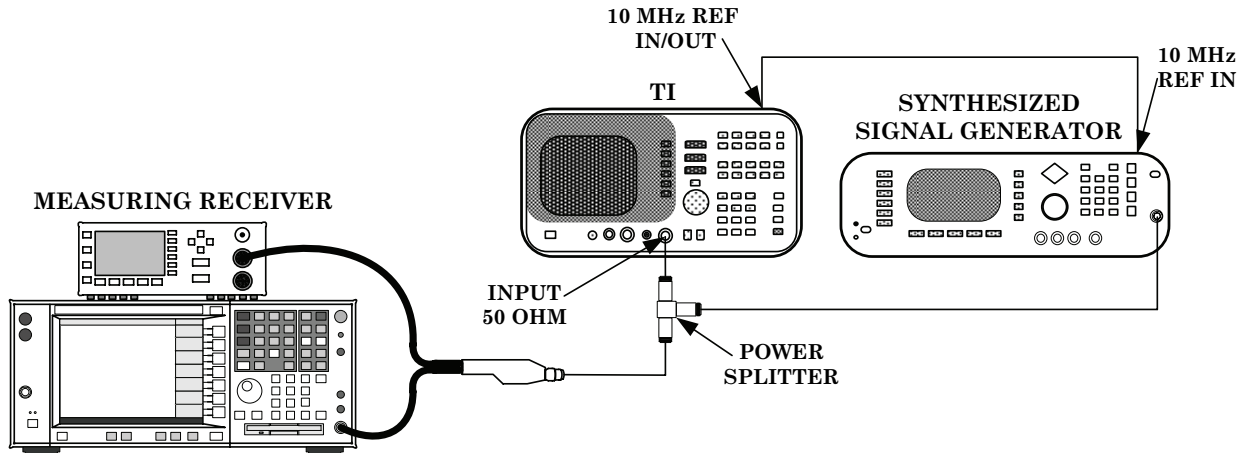

Figure 4. Frequency response - equipment setup.

- (2) Press TI keys and enter values using **DATA** keys as listed in (a) through (g) below:
  - (a) **INSTRUMENT STATE PRESET.**
  - (b) **INSTRUMENT STATE RECALL.**
  - (c) **[MORE].**
  - (d) **[FACTORY PRSEL PK].**
  - (e) **FREQUENCY** then **[CENTER FREQ]** to **300 MHz.**
  - (f) **SPAN** then **[SPAN WIDTH]** to **1 MHz.**
  - (g) **AMPLITUDE** then **[LOG dB/DIV]** to **2 dB/DIV.**
- (3) Set synthesized signal generator frequency to 300 MHz and level output to -5 dBm.
- (4) Press **MARKER PEAK SEARCH** key.
- (5) Set measuring receiver to measure RF power in dBm at 300 MHz.

(6) Adjust synthesized signal generator level output for a TI **MKR** amplitude indication between -9.95 and -10.05 dBm.

(7) Record measuring receiver indication.

(8) Set synthesized signal generator frequency to 18 GHz.

(9) Set measuring receiver to measure RF power in dBm at synthesized signal generator frequency.

(10) Press TI **FREQUENCY** key then [**CENTER FREQ**] to 18 GHz.

(11) Press **MARKER PEAK SEARCH** key.

(12) Repeat (6) above. Measuring receiver indication will be within  $\pm 4$  dB of indication recorded in (7) above.

(13) Repeat (8) through (12) above setting synthesized signal generator frequency and TI [**CENTER FREQ**] to 17.5, 17, 16.5, 16, 15.5, 15, 14.5, 14, and 13.5 GHz.

(14) Repeat technique of (8) through (12) above setting synthesized signal generator frequency and TI [**CENTER FREQ**] to 13, 12.5, 12, 11.5, 11, 10.5, 10, 9.5, 9, 8.5, 8, 7.5, and 7 GHz. Measuring receiver indication will be within  $\pm 3$  dB of indication recorded in (7) above.

(15) Repeat technique of (8) through (12) above setting synthesized signal generator frequency and TI [**CENTER FREQ**] to 6.46, 6, 5.5, 5, 4.5, 4, and 3.5 GHz. Measuring receiver indication will be within  $\pm 2.5$  dB of indication recorded in (7) above.

(16) Repeat technique of (8) through (12) above setting synthesized signal generator frequency and TI [**CENTER FREQ**] to 2.9 GHz, 2 GHz, 1.5 GHz, 1 GHz, 500 MHz, 100 MHz, 50 MHz, and 20 MHz. Measuring receiver indication will be within  $\pm 1.5$  dB of indication recorded in (7) above.

(17) Set synthesized signal generator frequency to 10 MHz.

(18) Repeat (9) above.

(19) Press TI **FREQUENCY** key then [**CENTER FREQ**] to 10 MHz.

(20) Press TI **SPAN** key then [**SPAN WIDTH**] to 10 kHz.

(21) Press **MARKER PEAK SEARCH** key.

(22) Adjust synthesized signal generator level output for a TI **MKR** amplitude indication between -9.95 and -10.05 dBm.

(23) Measuring receiver indication will be within  $\pm 1.5$  dB of indication recorded in (7) above. Record measuring receiver indication.

(24) Connect equipment as shown in figure 5.

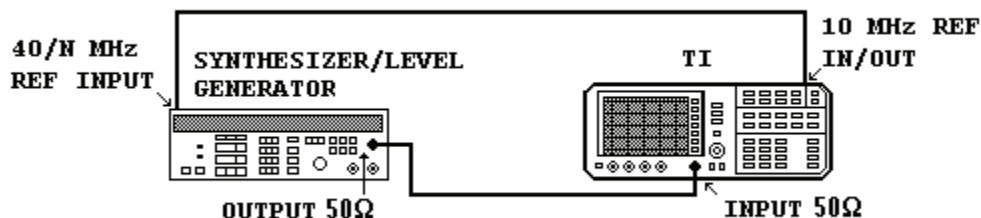

Figure 5. Frequency response - equipment setup.

- (25) Press synthesizer/level generator keys to values as listed in (a) through (c) below:
- FREQUENCY** to **10 MHz**.
  - AMPLITUDE** to **-4 dBm**.
  - AMPTD INCR** to **0.1 dB**.
- (26) Press TI **MARKER PEAK SEARCH** key.
- (27) Slowly adjust synthesizer/level generator amplitude until TI **MKR** indication is as close as possible to measuring receiver indication recorded in (23) above.
- (28) Set synthesizer/level generator frequency to 1 MHz.
- (29) Press **FREQUENCY** key then [**CENTER FREQ**] to **1 MHz**.
- (30) Press **MARKER PEAK SEARCH** key.
- (31) TI **MKR** indication will be within  $\pm 1.5$  dB of measuring receiver indication recorded in (7) above.
- (32) Repeat (28) through (31) above for synthesizer/level generator frequency and TI [**CENTER FREQ**] 100 kHz and 9 kHz settings.

**b. Adjustments.** Refer to paragraph 1 a.

## 17. Residual Responses

### a. Performance Check

- Connect TI **CAL OUTPUT** to **INPUT 50 Ω**.
- Press TI keys and enter values using **DATA** keys as listed in (a) through (j) below:
  - INSTRUMENT STATE PRESET**.
  - FREQUENCY** then [**CENTER FREQ**] to **300 MHz**.
  - SPAN** then [**SPAN WIDTH**] to **10 kHz**.
  - CONTROL BW** then [**RES BW**] to **300 Hz**.
  - AMPLITUDE** then [**REF LVL**] to **-10 dBm**.
  - [**ATTEN**] to **0 dB**.
  - MARKER PEAK SEARCH**.
  - AMPLITUDE**.
  - [**MORE**].

(j) **[REF LVL CAL]**.

(3) Slowly adjust TI knob until **MKR** amplitude indication is between -9.83 and -10.17 dBm.

(4) Press **[STORE REF LVL]** key.

(5) Disconnect TI **CAL OUTPUT** from **INPUT 50 Ω** and connect a 50 Ω termination to **INPUT 50 Ω**.

(6) Press TI keys and enter values using **DATA** keys as listed in (a) through (i) below:

(a) **INSTRUMENT STATE PRESET**.

(b) **FREQUENCY** then **[CENTER FREQ]** to **15.2 MHz**.

(c) **SPAN** then **[SPAN WIDTH]** to **30 MHz**.

(d) **FREQUENCY** then **[CF STEP]** to **28.5 MHz**.

(e) **AMPLITUDE** then **[REF LVL]** to **-50 dBm**.

(f) **[ATTEN]** to **0 dB**.

(g) **CONTROL BW** then **[RES BW]** to **10 kHz**.

(h) **CONTROL TRIG** then **[SINGLE]**.

(i) **CONTROL DISPLAY** then **[DISPLAY LINE]** to **-90 dBm**.

(7) Press TI **CONTROL TRIG** key, then **[SINGLE]** key, and wait for completion of sweep. The noise level will be at least 6 dB below the display line; if not, reduce **SPAN [SPAN WIDTH]** and **CONTROL BW [RES BW]** values to reduce noise level.

**NOTE**

If **SPAN** is reduced, **[CF STEP]** reduction must be no more than 95 percent of the **SPAN**.

(8) If a residual is not present proceed to (13) below. If residual is suspected, press **CONTROL TRIG** key then **[SINGLE]** key. Record the amplitude and frequency of any response above the display line.

**NOTE**

Noise peak will not persist when **[SINGLE]** key is pressed. However a residual response will persist.

(9) If response is marginal, press TI keys as listed in (a) through (d) below:

(a) **INSTRUMENT STATE SAVE**.

(b) **[SAVE STATE]**.

(c) **[STATE 0]**.

(d) **MARKER ON**.

(10) Position marker on peak of response in question and press TI keys as listed in (a) through (e) below:

(a) **MARKER MKR→** then **[MARKER→ CF]**.

(b) **SPAN** then **[SPAN WIDTH]**.

- (c) **STEP** ↓ four times.
- (d) **CONTROL TRIG** then **[CONT]**.
- (e) **CONTROL BW** then **[RES BW AUTO]**.

(11) Reduce **SPAN [SPAN WIDTH]** and **CONTROL BW [RES BW]** until **[RES BW]** is **300 Hz**. Record the frequency and amplitude of any residual response above the display line. Residual responses will be <-90 dBm.

(12) Press TI keys as listed in (a) through (c) below:

- (a) **INSTRUMENT STATE RECALL**.
- (b) **[RECALL STATE]**.
- (c) **[STATE 0]**.

(13) Press TI **FREQUENCY** key then **[CENTER FREQ]** key.

(14) Press **STEP** ↑ key.

(15) Repeat (7) through (14) above to check for residuals up to 2.9 GHz.

(16) Press TI **FREQUENCY** key then **[CENTER FREQ]** to **2.915 GHz** and repeat (7) through (14) above to check residuals up to 6.46 GHz.

**b. Adjustments.** No adjustments can be made.

## 18. Power Supply

### NOTE

Do not perform power supply check if all other parameters are within tolerance.

#### a. Performance Check

- (1) Press TI **LINE** switch to **OFF**.

### WARNING

Allow 30 seconds for the high-voltage capacitors to discharge before removing the protective cover from the A6 power supply (located at TI top).

- (2) Remove A6 power supply cover.
- (3) Set multimeter to measure 1000V dc.
- (4) Connect multimeter **INPUT HI** to A6TP405 (fig. 6) and **INPUT LO** to A6TP401 (fig. 6).
- (5) Record dc voltage marked on A6A1 HV module (located at TI top).
- (6) Note the value of inductor A6L401 (fig. 6). If A6L401 (fig. 6) is 10 mH, perform (7) and (8) below. If A6L401 (fig. 6) is 20 mH, perform (7) and (9) below.
- (7) Press TI **LINE** switch to **ON**.

**NOTE**

Perform (8) below ONLY if A6L401 (fig. 6) is 10 mH.

(8) If multimeter does not indicate a dc voltage equal to 2 V above the dc voltage recorded in (5) above, perform **b** (1) below.

**NOTE**

Perform (9) below ONLY if A6L401 (fig. 6) is 20 mH.

(9) If multimeter does not indicate a dc voltage equal to the dc voltage recorded in (5) above, perform **b** (2) below.

(10) Press TI LINE switch to **OFF**.

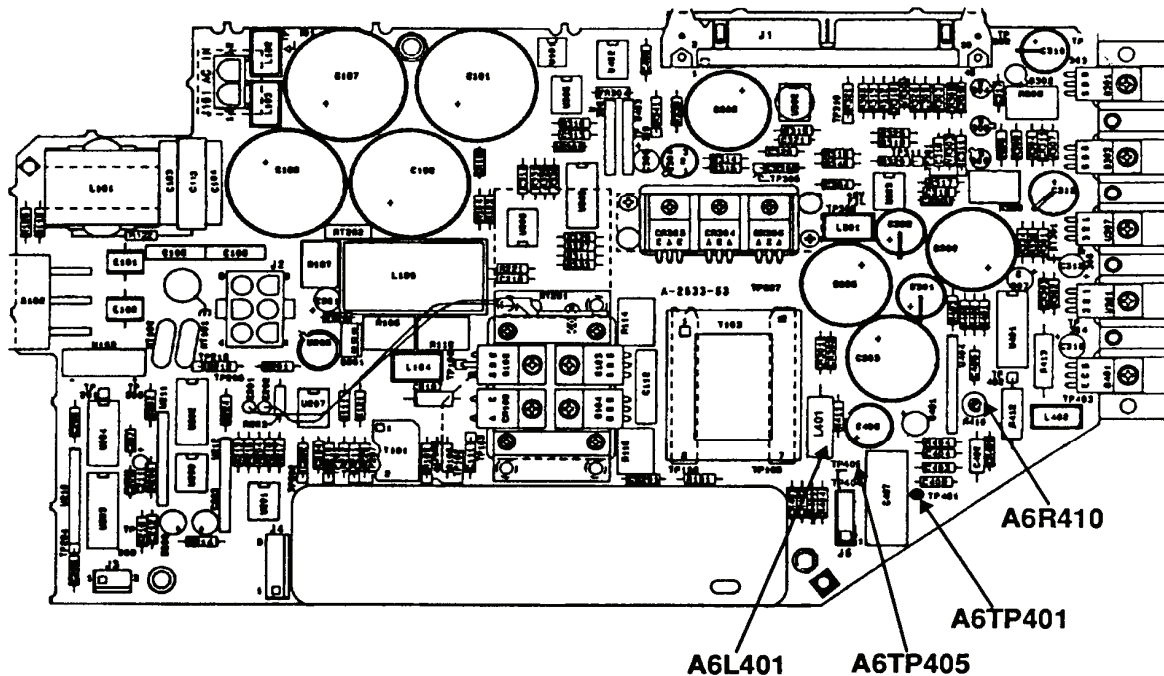

Figure 6. Power supply location sheet.

**b. Adjustments**

(1) Adjust A6R410 (fig. 6) for a dc voltage equal to 2 V above the dc voltage recorded in (5) above (R).

(2) Adjust A6R410 (fig. 6) for a dc voltage equal to the dc voltage recorded in (5) above (R).

**19. Final Procedure**

**a.** Deenergize and disconnect all equipment.

**b.** Annotate and affix DA label/form in accordance with TB 750-25.



By Order of the Secretary of the Army:

Official:



JOYCE E. MORROW  
*Administrative Assistant to the  
Secretary of the Army*

0815001

GEORGE W. CASEY, JR.  
*General, United States Army  
Chief of Staff*

Distribution:

To be distributed in accordance with the initial distribution number (IDN) 344794, requirements for calibration procedure TB 9-6625-2351-24.



### Instructions for Submitting an Electronic 2028

The following format must be used if submitting an electronic 2028. The subject line must be exactly the same and all fields must be included; however, only the following fields are mandatory: 1, 3, 4, 5, 6, 7, 8, 9, 10, 13, 15, 16, 17, and 27.

From: "Whomever" [whomever@redstone.army.mil](mailto:whomever@redstone.army.mil)

To: <2028@redstone.army.mil

Subject: DA Form 2028

1. **From:** Joe Smith
2. **Unit:** home
3. **Address:** 4300 Park
4. **City:** Hometown
5. **St:** MO
6. **Zip:** 77777
7. **Date Sent:** 19-OCT-93
8. **Pub no:** 55-2840-229-23
9. **Pub Title:** TM
10. **Publication Date:** 04-JUL-85
11. **Change Number:** 7
12. **Submitter Rank:** MSG
13. **Submitter FName:** Joe
14. **Submitter MName:** T
15. **Submitter LName:** Smith
16. **Submitter Phone:** 123-123-1234
17. **Problem:** 1
18. **Page:** 2
19. **Paragraph:** 3
20. **Line:** 4
21. **NSN:** 5
22. **Reference:** 6
23. **Figure:** 7
24. **Table:** 8
25. **Item:** 9
26. **Total:** 123
27. **Text**

This is the text for the problem below line 27.







This fine document...

Was brought to you by me:



## [Liberated Manuals -- free army and government manuals](#)

Why do I do it? I am tired of sleazy CD-ROM sellers, who take publicly available information, slap “watermarks” and other junk on it, and sell it. Those masters of search engine manipulation make sure that their sites that sell free information, come up first in search engines. They did not create it... They did not even scan it... Why should they get your money? Why are not letting you give those free manuals to your friends?

I am setting this document FREE. This document was made by the US Government and is NOT protected by Copyright. Feel free to share, republish, sell and so on.

I am not asking you for donations, fees or handouts. If you can, please provide a link to [liberatedmanuals.com](http://liberatedmanuals.com), so that free manuals come up first in search engines:

<A HREF=<http://www.liberatedmanuals.com/>>Free Military and Government Manuals</A>

- Sincerely  
Igor Chudov  
<http://igor.chudov.com/>
- [Chicago Machinery Movers](#)