

## TECHNICAL BULLETIN

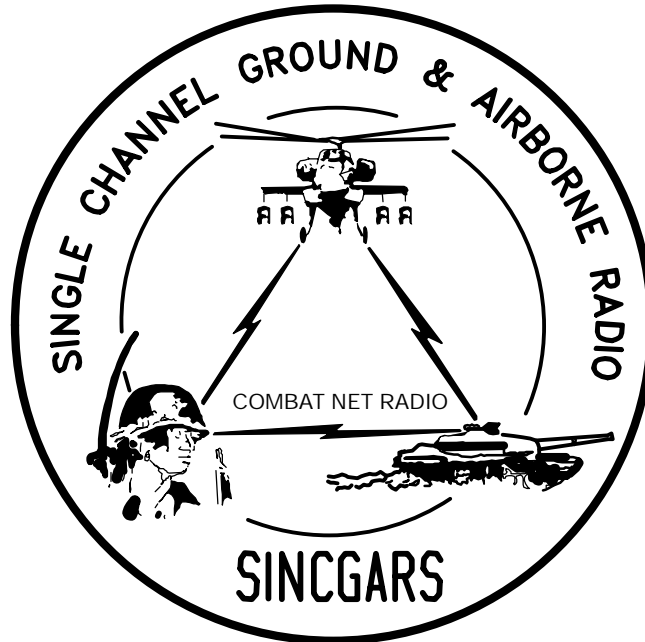

INSTALLATION INSTRUCTIONS FOR  
INSTALLATION KIT, ELECTRONIC EQUIPMENT  
MK- 2295/VRC (NSN 5895- 01- 295- 2503) (EIC: N/A)  
TO PERMIT INSTALLATION OF  
RADIO SET AN/VRC- 87/88/90 SERIES  
IN A  
COUNTERMEASURES SET, SPECIAL PURPOSE,  
AN/MLQ- 34

Approved for public release; distribution is unlimited.

---

HEADQUARTERS, DEPARTMENT OF THE ARMY

1 AUGUST 1999

**INSTALLATION INSTRUCTIONS FOR  
INSTALLATION KIT, ELECTRONIC EQUIPMENT  
MK- 2295/VRC (NSN 5895- 01- 295- 2503)(EIC: N/A)  
TO PERMIT INSTALLATION OF RADIO SET AN/VRC- 87/88/90 SERIES  
IN A  
COUNTERMEASURES SET, SPECIAL PURPOSE, AN/MLQ- 34**

**REPORTING OF ERRORS AND RECOMMENDING IMPROVEMENTS**

You can help improve this manual. If you find any mistakes, or if you know of a way to improve the procedures, please let us know. Mail your letter, DA Form 2028 (Recommended Changes to Publications and Blank Forms) or DA 2028±2 located in back of this manual direct to: Commander, US Army Communications±Electronics Command Fort Monmouth, ATTN: AMSEL±LC±LEO±D±CS±CFO, Fort Monmouth, New Jersey 07703±5000. The Fax number is 732±532±1413, DSN 992±1413. You may also e±mail your recommendation to AMSEL±LC±LEO±PUBS±CHG@ce-com3.monmouth.army.mil.

In either case a reply will be furnished direct to you.

TABLE OF CONTENTS

Subject	Section	Page
Scope .....	0.1	1
General Information .....	0.2	1
Maintenance Forms, Records, and Reports .....	0.3	1
Reports of Maintenance and Unsatisfactory Equipment .....	0.3.1	1
Report of Packing and Handling Deficiencies .....	0.3.2	1
Discrepancy in Transportation Deficiency Report (TDR) (SF 361) .....	0.3.3	1
Consolidated Index of Army Publications .....	0.4	1
Purpose of Installation .....	1.	2
End Item or System to be Modified .....	2.	2
Application Times .....	3.	2
Time for Completion of Installation .....	3.1	2
Time for Installation of One Assembly or Component .....	3.2	2
Preparation for Installation .....	4.	2
Preparation of Shelter .....	4.1	2
Preparation of MK .....	4.2	2
MK, Distribution, and Consumables .....	4.3	3
Tools and Test, Measurement, and Diagnostic Equipment (TMDE) Required ...	4.4	6
Installation Procedures .....	5.	7
Installation of Antenna AS-3900/VRC (antenna) .....	5.1	9
Installation of Antenna Base .....	5.1.1	9
Installation of Top Antenna Assembly .....	5.1.2	10
Installation of Mounting Base, Electrical Equipment MT-6352/VRC (mounting base) .....	5.2	11
Installation of Cables .....	5.3	13
Post-Installation and Checkout .....	5.4	15
Appendix A. References .....		A1

\*This manual supersedes TB 11±5820±890±20±13, dated 1 September 1993.

LIST OF ILLUSTRATIONS

Figure	Title	Page
4-1	MK Illustrated Parts List .....	5
5-1(1)	MK and Radio Installation: MK Equipment Locations .....	7
5-1(2)	MK and Radio Installation: Radio Equipment Locations .....	8
5-2	Antenna Base Installation .....	9
5-3	Top Antenna Assembly Installation .....	10
5-4	Mounting Base Installation .....	11
5-5	Cable Installation .....	14
5-6	Cable Diagram: For AN/VRC-87/88/90 Series .....	16

LIST OF TABLES

Number	Title	Page
4-1	Parts List for Installation of Radio Set AN/VRC-87/88/90 Series .....	4

## 0.1 SCOPE

This technical bulletin provides Installation Instructions for Electronic Equipment MK-2295/VRC, commonly referred to as the Mounting Kit (MK). The MK shall be installed into the following type of shelter(s):

Countermeasures Set, Special Purpose, AN/MLQ-34

The MK is used for installation of radio set components at field locations. The information contained in this technical bulletin is the official authorization to perform the installation at the unit maintenance level.

### NOTES

This technical bulletin is not an authorization for requisition or turn-in of shelters.

This technical bulletin does not establish quantity or types of shelters assigned to using units.

This technical bulletin does not contain information on the maintenance or replacement of the MKs. This information is contained in the MAC of TM 11-5820-890-20-2 and RPSTL of TM 11-5820-890-20P.

## 0.2 GENERAL INFORMATION.

The MK becomes operable when all the radio set components are installed in the shelter and correct power is supplied. Refer to TM 11-5820-890-20-1 or TM 11-5820-890-20-2 for installation, Operational (OP) Check instructions, and required maintenance procedures. Refer to TM 11-5820-890-20P for repair parts.

Included in the Radio Set AN/VRC-87/88/90 Series is:

Radio Set AN/VRC-87/88/90 Series (for RT-1523(C)/U)

## 0.3 MAINTENANCE FORMS, RECORDS, AND REPORTS.

0.3.1 Reports of Maintenance and Unsatisfactory Equipment. See section 4.2.2.3 for information.

0.3.2 Report of Packaging and Handling Deficiencies. See section 4.2.2.1 for information.

0.3.3 Discrepancy in Transportation Deficiency Report (TDR) (SF361). See section 4.2.2.2 for information.

## 0.4 CONSOLIDATED INDEX OF ARMY PUBLICATIONS.

Refer to the latest issue of DA Pam 25-30 to determine whether there are new changes, or additional publications pertaining to the equipment.

1. PURPOSE OF INSTALLATION.

The Electronic Equipment MK-2295/VRC (MK) contains the items needed to mount Radio Set AN/VRC- 87/88/90 Series in a Countermeasures Set, Special Purpose, AN/MLQ-34.

2. END ITEM OR SYSTEM TO BE MODIFIED.

Not applicable.

3. APPLICATION TIMES.

3.1 Time for Completion of Installation. Using one person, a total of 3.0 work hours is required. Typical shelter downtime is 3.5 hours.

3.2 Time for Installation of One Assembly or Component. The following table lists the time required to install one component. All times have been rounded off to the nearest half hour. The sum of these times will not reflect the typical shelter downtime.

ITEM	SECTION	TIME
Antenna AS-3900/VRC	5.1	0.5
Mounting Base, Electrical Equipment MT-6352/VRC	5.2	1.5
Cables	5.3	1.0

4. PREPARATION FOR INSTALLATION.

This section explains how to prepare the shelter and MK for installation.

4.1 Preparation of Shelter. To prepare the shelter for installation, insure that the site includes adequate lighting and a power source when drilling is required. Inspect the shelter for damage that could affect installation. Have any such damage repaired before installing MK.

4.1.1 Items to be Removed. Remove existing AN/VRC-12 radio family installation kit/harness. See TM 11-5820-401-20-2 for removing items used with intercom systems, or TM 11-5820-401-20-1 (used without intercom systems), and TM 32-5865-060-24.

4.1.2 List of Items to be Retained. Not applicable.

4.2 Preparation of MK. To prepare MK, unpack, inspect and check inventory.

4.2.1 Precautions During Handling. Observe these steps to prevent equipment damage.

- a. Keep dust covers in place on connectors.
- b. Do not disassemble or modify parts in MK unless authorized to do so.
- c. Keep mounting hardware covered and protected until needed.
- d. When exposed to moisture, rain or salt water, keep all parts dry to prevent corrosion.

#### 4.2.2 Unpack and Inspect Equipment.

4.2.2.1 Inspect Packaging for Evidence of Damage. Any shipping damage should be reported on SF364 Report of Discrepancy (ROD) as prescribed in AR 735-11-2/DLAR 4140.55/NAVMATINST 4355.73A/AFR 400-64/MCO 4430.3F.

4.2.2.2 Unpack and Inventory MK. If any item is missing, fill out and forward Transportation Deficiency Report (TDR) (SF361) as described in AR 55-38/NAVSUPINST 4610.33C/AFR 75-18/MCO P4610.19D/DLAR 4500.15.

4.2.2.3 Examine Each Item for Damage. If any item is damaged, fill out and forward SF364 Report of Discrepancy (ROD) as prescribed in AR 735-11-2/DLAR 4140.55/NAVMATINST 4355.73A/AFR 400-64/MCO 4430.3F. All damages should be reported as prescribed by DA Pam 738-750, as contained in Maintenance Management Up date.

#### 4.3 MK, Distribution, and Consumables.

4.3.1 Items Supplied in MK and/or Required for Installation. Use Table 4-1 and figure 4-1 to identify and inventory MK parts supplied to install Radio Set AN/VRC-87/88/90 Series.

#### 4.3.2 Distribution and Issue Instructions.

- a. US Forces: Do not requisition MK. They will be shipped automatically.
- b. US Army Depots: Requisition MK through supply channels.
- c. Multiservice: Instructions shall be included for multiservice modifications.
- d. MAP/MAS Countries: Instructions shall be provided for MAP/MAS countries.

Table 4- 1. Parts List for Installation of Radio Set AN/VRC- 87/88/90 Series

NSN	ITEM DESCRIPTION AND PART NUMBER	QUANTITY IN MK	SMR CODE	FIGURE, ITEM NO.
5985-01-297-2971	Antenna AS-3900/VRC (A3017899-1)	1	PAOOF A	4-1, 2
5305-00-847-1159	Screw, Cap, Hexagon (3/8-16 x 1 3/4 in) MS35307-365	4	PAOZZA	
5310-00-913-8881	Nut, Hexagon (3/8-16 in) MS51971-3	4	PAOZZA	4-1, 1
5310-00-061-1258	Washer, Lock, Internal/External-Toothed (3/8 in) MS45904-76	8	PAOZZA	
5310-00-889-2527	Washer, Lock, Internal/External-Toothed (5/16 in) MS45904-72	2	PAOZZA	
5306-00-225-9086	Bolt, Machine (5/16-24 x 5/8 in) MS90726-31 (Not Used)	1	PAOZZA	
5330-01-205-2864	Gasket (A3013655-1)	1	PAOZZA	
5975-01-188-8873	Mounting Base, Electrical Equipment MT-6352/VRC (A3013367-1)	1	PAOOF A	
5306-00-225-9089	Bolt, Machine (5/16-24 x 1 in) MS90726-34	5	PAOZZA	
5310-00-889-2527	Washer, Lock, Internal/External-Toothed (5/16 in) MS45904-72	10	PAOZZA	
5310-00-880-7746	Nut, Hexagon (5/16 - 24 in) MS51968-5	5	PAOZZA	
5935-01-037-3476	Adapter, Connector M55339/16-00914	1	PAOZZA	
4020-01-341-8795	Fiber Rope Assembly, Single Leg (A3167672-1)	1	PAOZZA	4-1, 4

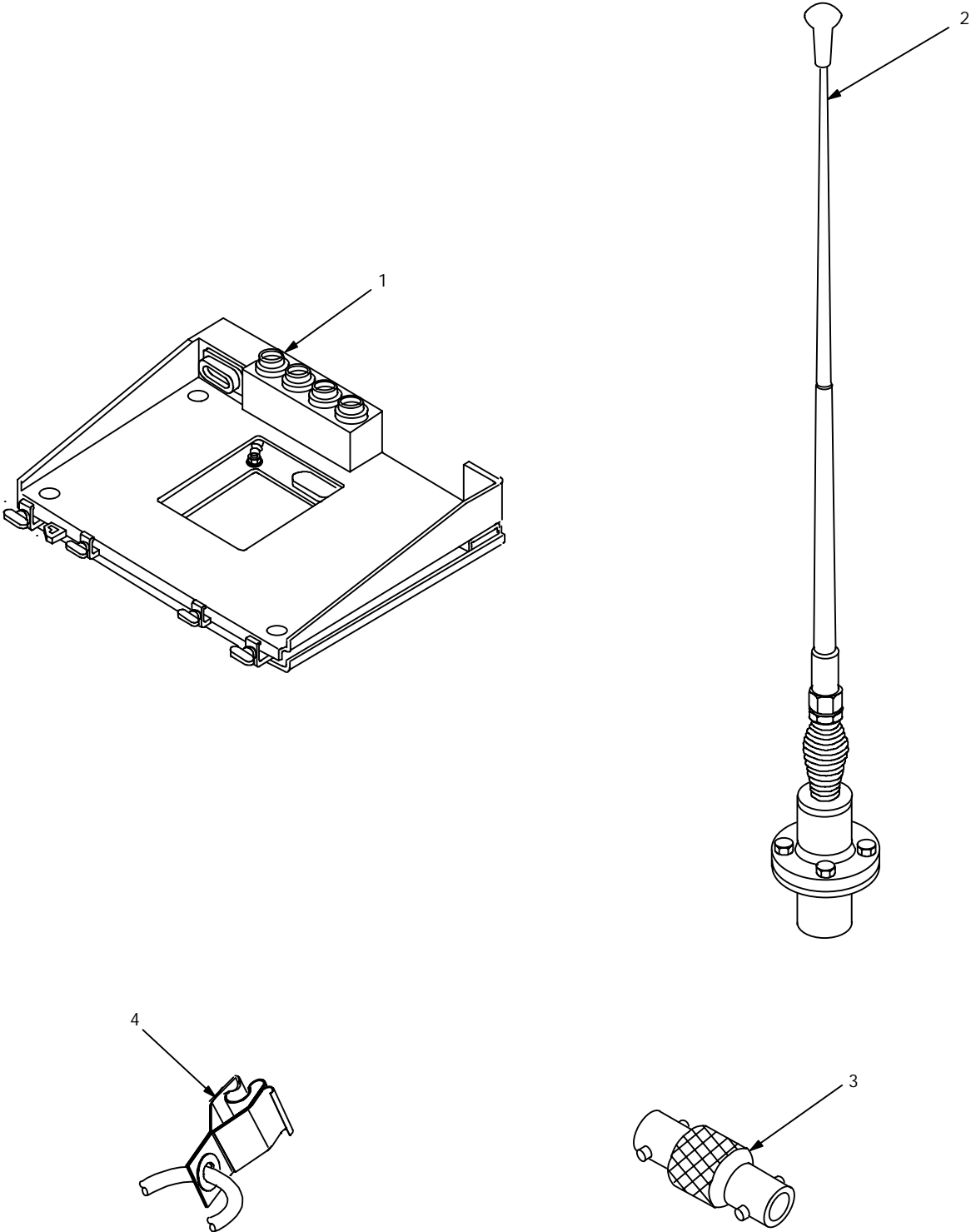

Figure 4- 1. MK Illustrated Parts List



4.3.3 Consumable Materials. The table below lists materials required for installation but not supplied with MK.

NSN	NOMENCLATURE
8040- 00- 117- 8510	Adhesive- Sealant, Clear, RTV
6850- 00- 880- 7616	Silicone Compound, MIL- S- 8660
8030- 00- 292- 1102	Conductive Anti- seize Compound

4.4 Tools and Test, Measurement, and Diagnostic Equipment (TMDE) Required. The following tools and TMDE are needed for installation.

NOMENCLATURE	NSN	QUANTITY
Radio Set*		1
Electric Grinder or Equivalent		1
Pocket Knife, Electrician's	5110-00-240-5943	1
Screwdriver, No. 2 Point Phillips, 4 in	5120-00-234-8913	1
Screwdriver, 1/4 in Flatblade, 4 in	5120-00-222-8852	1
Pliers, Round Nose	5120-00-240-6172	1
Pliers, Diagonal Cutting	5110-00-965-0974	1
Wrench, Open/Box: 7/16 in	5120-00-228-9505	1
1/2 in	5120-00-228-9506	1
9/16 in	5120-00-228-9507	1
Handle, Socket Wrench	5120-00-240-5364	1
Socket: 7/16 in	5120-00-227-6703	1
1/2 in	5120-00-237-0977	1
9/16 in	5120-00-227-6704	1
Electric Drill	5130-00-889-8994	1
Drill Bits: 3/16	5133-00-227-9654	1
Size Z (.413)	5133-00-262-2174	1

\* Use radio issued with your vehicle if available.

5. INSTALLATION PROCEDURES.

This section describes where and how to install MK items in the shelter. See figure 5- 1 for an overall view of where the MK equipment, as well as radio components, typically will be installed. When installing MK equipment, be sure to read and follow instructions and illustrations carefully.

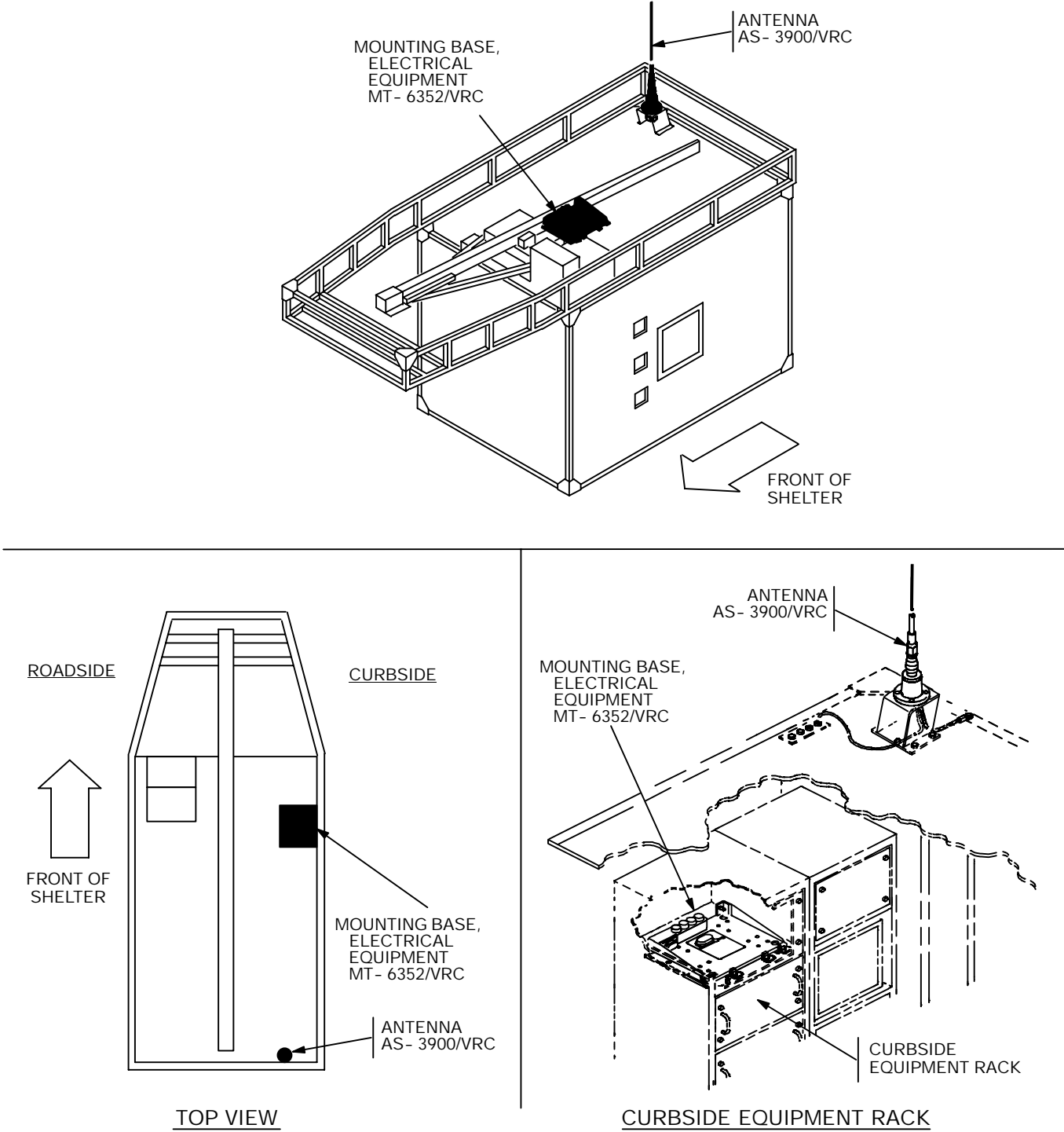

Figure 5- 1 (1). MK and Radio Installation: MK Equipment Locations

5. INSTALLATION PROCEDURES. Continued

INSTALLATION  
FOR  
AN/VRC- 87/88/90 Series

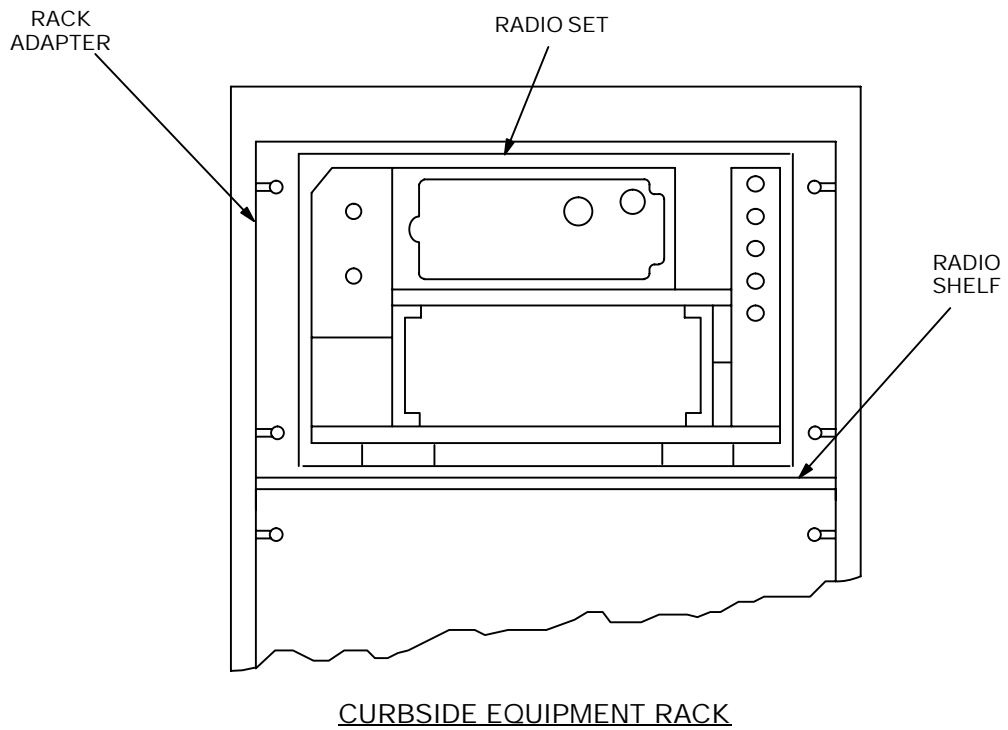

Figure 5- 1 (2). MK and Radio Installation:  
Radio Equipment Locations

5.1 Installation of Antenna AS- 3900/VRC (antenna). See figure 5- 1 (1) for location.

5.1.1 Installation of Antenna Base.

ITEM	ACTION	REMARKS
------	--------	---------

NOTE

Apply a thin coat of adhesive- sealant to both sides of each internal/external- toothed (IET) washer during installation, and to the area of contact where IET washer is to be placed.

- |  |   |  |
|--|---|--|
| a. Gasket (6).   | Place on existing antenna support and align mounting holes. See figure 5 2.                 |  |
| b. Antenna base (7).   | Place on top of gasket (6) and antenna support; then align mounting holes. See figure 5- 2. |  |
| c. Four cap screws (1), eight internal/external toothed (IET) washers (2) and four nuts (5). | Install and secure to antenna base (7) and antenna support.                                 | Tools: 9/16 in open/box wrench and 9/16 in socket. |
| d. Ground strap (4), two IET washers (3) and existing bolt.                                  | Install and secure to existing mounting hole in antenna support.                            |  |

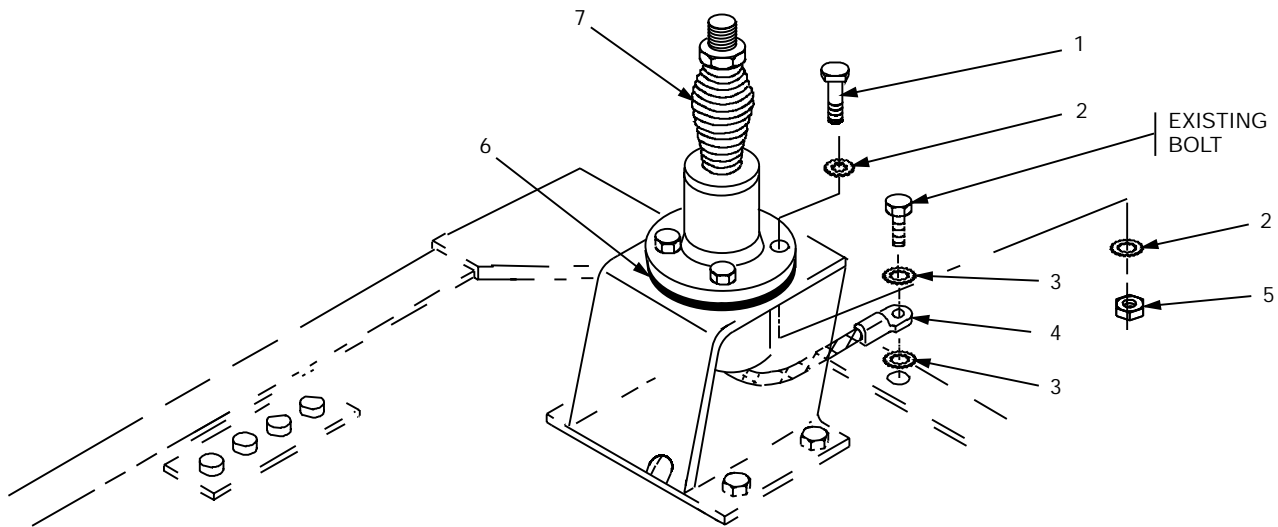

- 1. CAP SCREW (3/8- 16 x 1 3/4 in)
- 2. IET WASHER (3/8 in)
- 3. IET WASHER (5/16 in)
- 4. GROUND STRAP
- 5. NUT (3/8- 16 in)
- 6. GASKET
- 7. ANTENNA BASE

Figure5- 2. Antenna Base Installation: Rear Curbside

5.1.2 Installation of Top Antenna Assembly. The top portion of the antenna includes a lower element and an upper element (with installed cap). Use the following procedure to assemble, install and tie down all antennas.

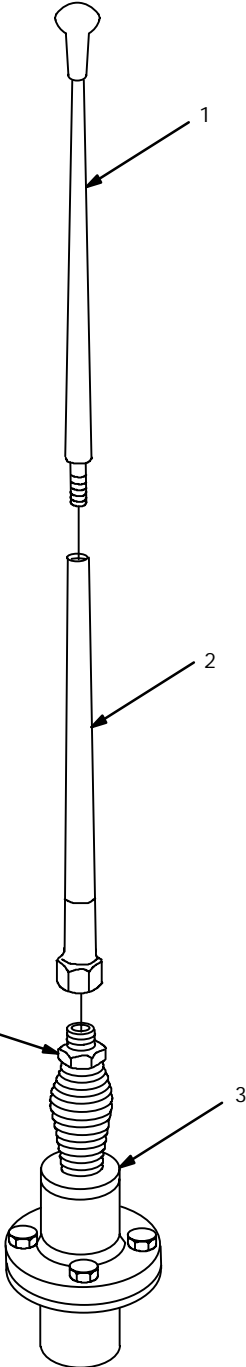
ITEM	ACTION	REMARKS
a. Antenna elements (1, 2).	Apply silicone compound to element threads and assemble. See figure 5- 3.	
b. Antenna element (2).	Install and hand- tighten to antenna base (3).	
c. Lock wire (4).	Install to antenna element (2) and antenna base (3). See figure 5- 3, detail A.  Cut and remove excess wire with diagonal cutting pliers.	
d. Fiber rope assembly (5).	Attach clip to antenna element (1). Tie rope to vehicle to position antenna in desired location. See figure 5- 3, detail B.	

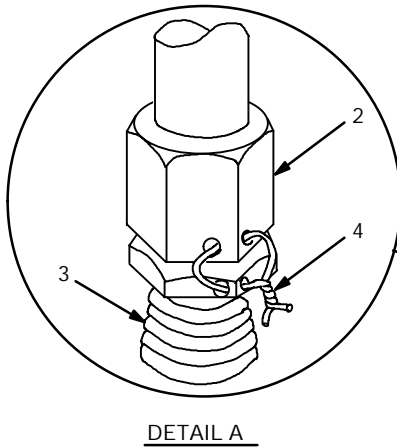
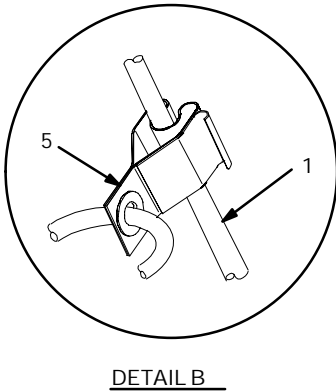

- 1. ANTENNA ELEMENT (UPPER)
- 2. ANTENNA ELEMENT (LOWER)
- 3. ANTENNA BASE
- 4. LOCK WIRE
- 5. FIBER ROPE ASSEMBLY

Figure 5- 3. Top Antenna Assembly Installation

5.2 Installation of Mounting Base, Electrical Equipment MT- 6352/VRC (mounting base). Continued.

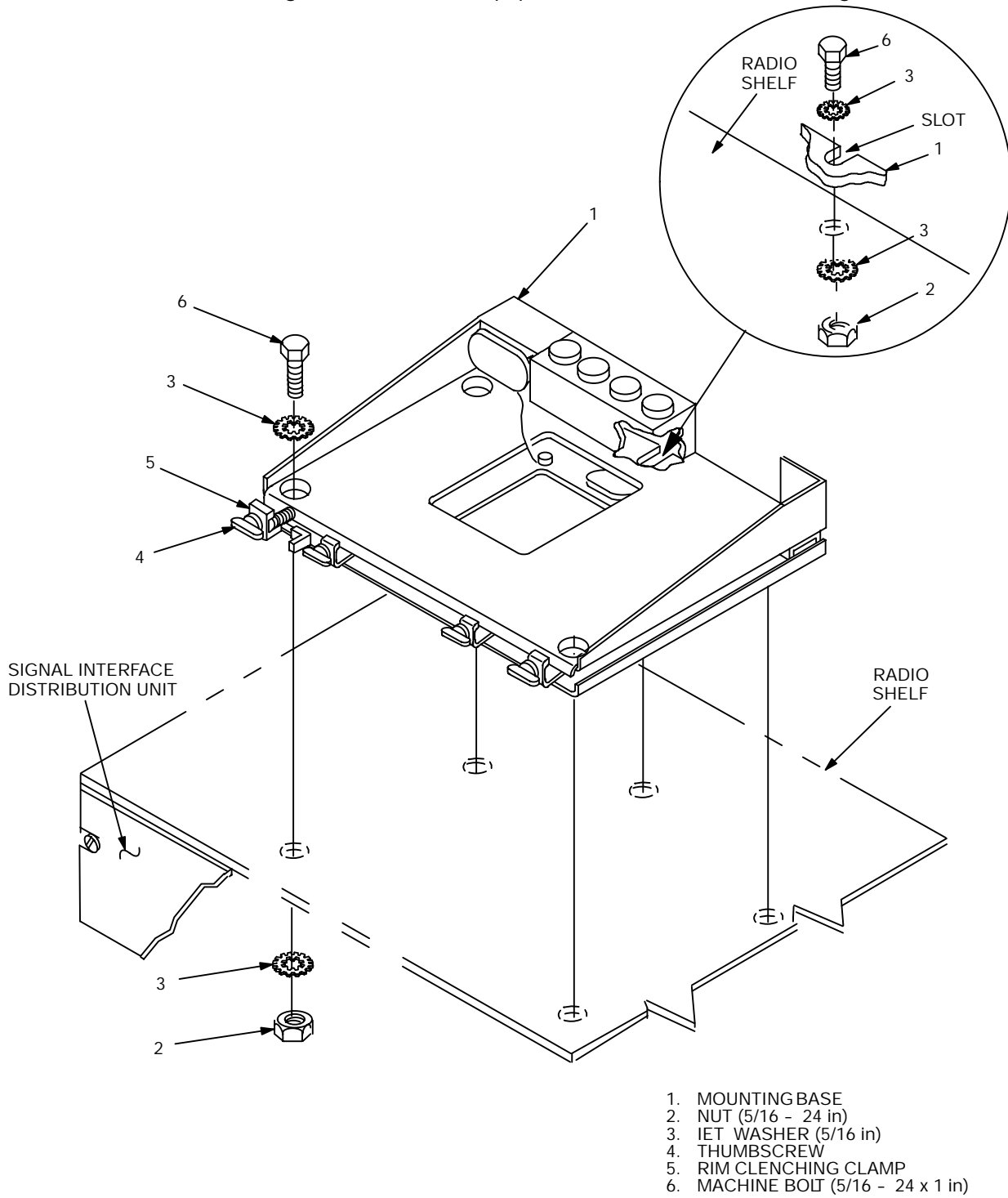

Figure 5- 4. Mounting Base Installation

5.2 Installation of Mounting Base, Electrical Equipment MT- 6352/VRC (mounting base). Remove and retain attaching bag of 5/16 in mounting hardware for installation. To insure good electrical grounding, any rust, corrosion or paint around mounting holes in radio shelf should be removed before installing the mounting base. See Figure 5- 4 and perform the following steps

ITEM	ACTION	REMARKS
NOTE		
Apply a thin coat of adhesive- sealant to both sides of each internal/external- toothed (IET) washer during installation, and to the area of contact where IET washer is to be placed.		
a. Signal interface distribution unit.	Temporarily remove and retain. See Figure 5- 4.	
b. Mounting base (1) and existing radio shelf.	Remove a 2" square area of paint on the underside of the mounting base (1) around left front and rear mounting holes. Remove a 2" square area of paint on the existing radio shelf around the existing mounting holes that mate with left front and rear mounting holes of mounting base (1). Clean the paint removed areas and apply a thin coat of conductive anti- seize compound.	Tools: Electric grinder or equivalent.
c. Mounting base (1).	Place on radio shelf over existing holes.	
d. Two outer thumbscrews (4).	Turn ccw until both sets of threads have cleared center of holes.	
e. Mounting base (1).	Align four holes and rear slot with matching hole pattern in existing radio shelf.	
f. Five machine bolts (6), ten internal/external- toothed (IET) washers (3) and five nuts (2).	Install and secure to mounting base (1) and radio shelf.	Tools: 1/2 in socket and 1/2 in open/box wrench.
g. Two outer thumbscrews (4).	Tighten and secure to rim clenching clamps (5) and mounting base (1).	

## 5.3 Installation of Cables.

WARNING

Make sure shelter power source is positioned OFF or disconnected before installing cables.

ITEM	ACTION	REMARKS
a. Existing RF cable (A18W1) and existing RF cable (A18W2).	Disconnect from existing bandpass filter and existing secure voice filter junction box. See figure 5- 5.	
b. Existing bandpass filter.	Remove from curbside equipment rack.	
c. Existing RF cable (W148) connector P2 and existing RF cable (W246) connector P1.	Disconnect from existing secure voice filter junction box.	
d. Existing RF cable (W148) connector P2.	Connect and secure to connector adapter (3).	
e. Existing RF cable (W246) connector P1.	Connect and secure to connector adapter (3).	
f. Existing RF cable (W292) connector P2.	Connect and secure to antenna base (1) connector J1.	
g. Existing RF cable (W148) connector P1.	Position on top of mounting base (2).	
h. Existing shelter intercom cable connector P1.	Connect and secure to mounting base (2) connector J3.	
i. Existing power cable connector P1.	Connect and secure to mounting base (2) connector J1.	



5.3 Installation of Cables. Continued

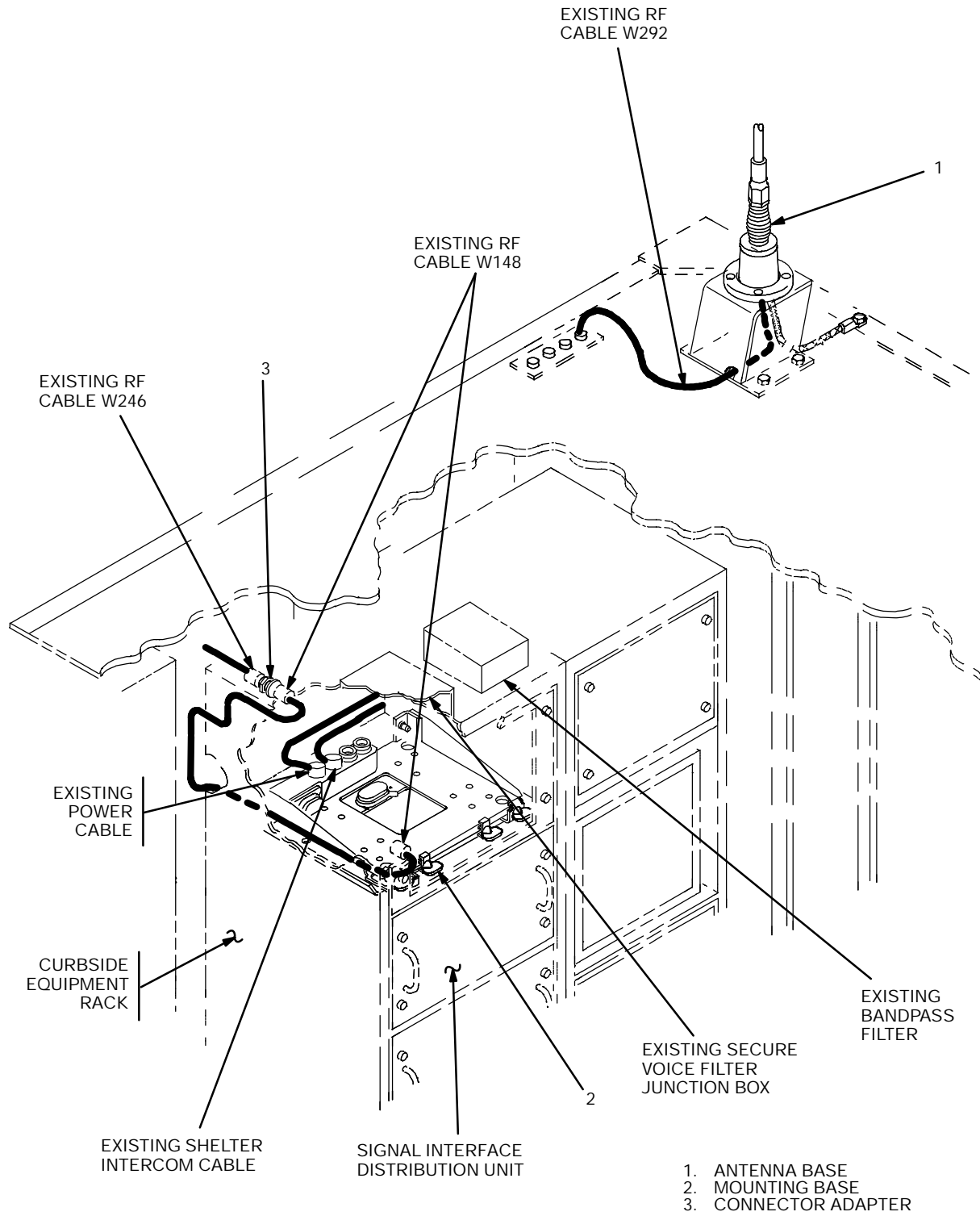
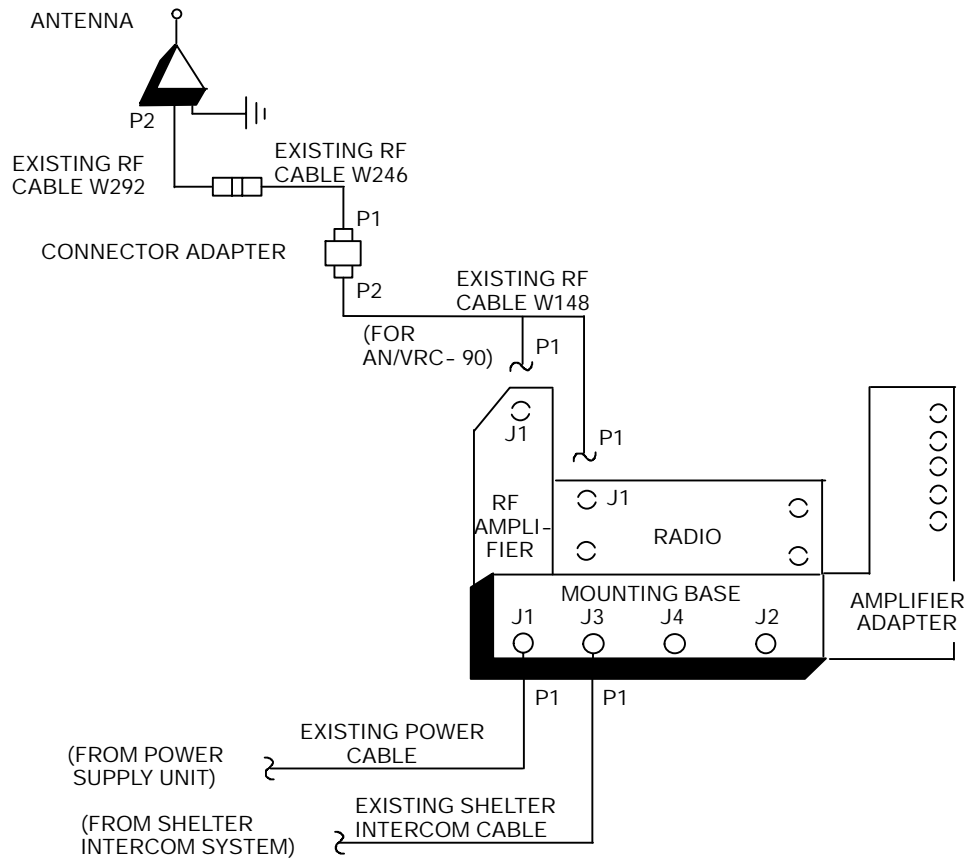

Figure 5- 5. Cable Installation

5.4 Post- Installation and Checkout. After equipment is installed and cables are connected, perform the following steps.

ITEM	ACTION	REMARKS
a. Equipment.	Check for secure mounting. Check for loose parts, connectors and mounting hardware.	
b. Cables.	Check for proper installation and connection of cables. See figure 5- 6 for cable connections. Unused cables should be stowed in appropriate place inside the shelter.	
c. Protective covers.	Insure that all installed cables are covered when not in use or connected.	
d. Radio issued with shelter.	Install and connect cables. See TM 11- 5820- 890- 20- 1 or TM 11- 5820- 890- 20- 2 for installation and Operational (OP) Check instructions.	
e. MK line replaceable units.	See TM 11- 5820- 890- 20P for Repair Parts and Special Tools List (RPSTL) information.	

5.4 Post- Installation and Checkout. Continued



CABLE ASSEMBLY	FROM			TO		
	CABLE CONN.	UNIT	UNIT CONN.	CABLE CONN.	UNIT	UNIT CONN.
Existing power cable		Power supply unit		P1	Mounting base	J1
Existing RF cable W292		Existing RF cable W246		P2	Antenna base	J1
Existing RF cable W246		Existing RF cable W292		P1	Connector adapter	
Existing RF cable W148	P1	RF amplifier or radio	J1	P2	Connector adapter	
Existing shelter intercom cable		Shelter intercom system		P1	Mounting base	J3

Figure 5- 6. Cable Diagram: For AN/VRC- 87/88/90 Series

## APPENDIX A

### REFERENCES

---

AMDF	Army Master Data File (Microfiche)
AR 710- 2	Supply Policy Below the Wholesale Level as Contained in Unit Supply UPDATE
AR 725- 50	Requisitioning, Receipt and Issuing System in UPDATE
DA Pam 25- 30	Consolidated Index of Army Publications (Microfiche)
DA Pam 710- 2- 1	Using Unit Supply System Manual Procedures as Contained in Unit Supply UPDATE
SB 11- 131	Vehicular Radio Sets and Authorized Installations (SINCGARS)
TM 11- 5820- 890- 10- 1	Operator's Manual (ICOM Radio Sets)
TM 11- 5820- 890- 10- 3	Operator's Manual (Non- ICOM Radio Sets)
TM 11- 5820- 890- 20- 1	Unit Maintenance Manual (ICOM Radio Sets)
TM 11- 5820- 890- 20- 2	Unit Maintenance Manual (Non- ICOM Radio Sets)
TM 11- 5820- 890- 20P	Repair Parts and Special Tools List

By Order of the Secretary of the Army:

Official:

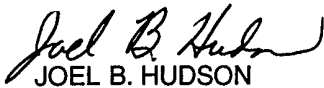

JOEL B. HUDSON  
*Administrative Assistant to the  
Secretary of the Army*

9916705

**ERIC K. SHINSEKI**  
*General, United States Army  
Chief of Staff*

**DISTRIBUTION:**

To be distributed in accordance with the initial distribution number (IDN) 369549 requirements for TB 11-5820-890-20-13.

RECOMMENDED CHANGES TO EQUIPMENT TECHNICAL PUBLICATIONS



THEN...JOT DOWN THE DOPE ABOUT IT ON THIS FORM. CAREFULLY TEAR IT OUT, FOLD IT AND DROP IT IN THE MAIL.

SOMETHING WRONG WITH PUBLICATION

FROM: (PRINT YOUR UNIT'S COMPLETE ADDRESS)

DATE SENT

PUBLICATION NUMBER

PUBLICATION DATE

PUBLICATION TITLE

BE EXACT PIN-POINT WHERE IT IS

PAGE NO.

PARA-GRAPH

FIGURE NO.

TABLE NO.

IN THIS SPACE, TELL WHAT IS WRONG AND WHAT SHOULD BE DONE ABOUT IT.

TEAR ALONG PERFORATED LINE

PRINTED NAME, GRADE OR TITLE AND TELEPHONE NUMBER

SIGN HERE



This fine document...

Was brought to you by me:



## [Liberated Manuals -- free army and government manuals](#)

Why do I do it? I am tired of sleazy CD-ROM sellers, who take publicly available information, slap “watermarks” and other junk on it, and sell it. Those masters of search engine manipulation make sure that their sites that sell free information, come up first in search engines. They did not create it... They did not even scan it... Why should they get your money? Why are not letting you give those free manuals to your friends?

I am setting this document FREE. This document was made by the US Government and is NOT protected by Copyright. Feel free to share, republish, sell and so on.

I am not asking you for donations, fees or handouts. If you can, please provide a link to [liberatedmanuals.com](http://liberatedmanuals.com), so that free manuals come up first in search engines:

<A HREF=<http://www.liberatedmanuals.com/>>Free Military and Government Manuals</A>

- Sincerely  
Igor Chudov  
<http://igor.chudov.com/>
- [Chicago Machinery Movers](#)