

**TECHNICAL BULLETIN**

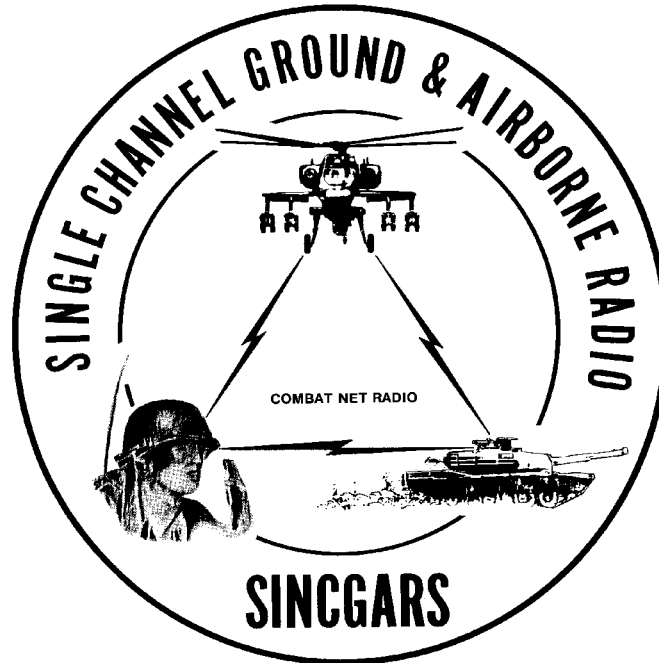

**INSTALLATION INSTRUCTIONS FOR  
INSTALLATION KIT,  
ELECTRONIC EQUIPMENT MK-2867/VRC  
(NSN 5895-01-442-4584) (EIC: N/A)  
TO PERMIT INSTALLATION OF MULTIPLEXER,  
FREQUENCY HOPPING TD-1456/VRC  
IN  
SINGARS-EQUIPPED VEHICLE (GENERIC)**

Approved for public release; distribution is unlimited.

---

**HEADQUARTERS, DEPARTMENT OF THE ARMY**

**1 JANUARY 2004**



TB 11-5820-890-20-112

INSERT LATEST CHANGED PAGES/WORK PACKAGES. DESTROY SUPERSEDED DATA.

LIST OF EFFECTIVE PAGES/WORK PACKAGES

NOTE: The portion of text affected by the changes is indicated by a vertical line in the outer margin of the page. Changes to illustrations are indicated by a vertical line adjacent to the title.

Date of issue for the original manual and changed pages/work packages are:

Original: 01 January 04

TOTAL NUMBER OF PAGES IS 36, CONSISTING OF THE FOLLOWING:

<b>Page/WP No.</b>	<b>*Change No.</b>	<b>Page/WP No.</b>	<b>*Change No.</b>
Front Cover/blank	0		
A/(B blank)	0		
i/ii	0		
1 - 16	0		
A-1/(A-2 blank)	0		
DA 2028	0		
Auth/blank	0		
Blank/Rear Cover	0		

\*Zero in this column indicates an original page.

A/(B blank)



**INSTALLATION INSTRUCTIONS FOR  
 INSTALLATION KIT, ELECTRONIC EQUIPMENT MK-2867/VRC  
 (NSN 5895-01-442-4584) (EIC: N/A)  
 TO PERMIT INSTALLATION OF MULTIPLEXER,  
 FREQUENCY HOPPING TD-1456/VRC  
 IN  
 SINGGARS-EQUIPPED VEHICLES (GENERIC)**

**REPORTING OF ERRORS AND RECOMMENDING IMPROVEMENTS**

You can help improve this manual. If you find any mistakes or if you know of a way to improve the procedures, please let us know. Mail your letter or DA Form 2028 (Recommended Changes to Publications and Blank Forms) direct to: Commander, US Army Communications-Electronics Command Fort Monmouth, ATTN: AMSEL-LC-LEO-D-CS-CFO, Fort Monmouth, NJ 07703-5006. The Fax number is 732-532-1413, DSN 992-1413. You may also e-mail your recommendation to: AMSEL-LC-LEO-PUBS-CHG@cecom3.monmouth.army.mil

In either case, a reply will be furnished direct to you.

**TABLE OF CONTENTS**

Subject	Section	Page
General Information.....	0.	1
Purpose of Installation .....	1.	3
End Item or System to be Modified.....	2.	3
Application Times.....	3.	3
Time for Completion of Installation.....	3.1	3
Time for Installation of One Assembly or Component.....	3.2	3
Preparation for Installation.....	4.	3
Preparation of Work Area.....	4.1	3
Preparation of Vehicle.....	4.2	3
Preparation of Installation Kit .....	4.3	3
Contents of Installation Kit.....	4.4	4
Consumable Materials Required.....	4.5	6
Tools and Test, Measurement, and Diagnostic Equipment (TMDE) Required.....	4.6	6
Installation Procedures .....	5.	7
Installation of Antenna, Vehicular, AS-3900A/VRC (antenna) .....	5.1	7
Installation of Antenna Mounting Base .....	5.1.1	7
Installation of Top Antenna Assembly.....	5.1.2	10
Installation of Mounting Base, Electrical Equipment MT-6845/VRC (mounting base).....	5.2	11
Installation of Cables.....	5.3	13
Post-Installation and Checkout .....	5.4	14
Appendix A References .....		A-1

LIST OF ILLUSTRATIONS

Figure	Title	Page
4-1	MK-2867/VRC Illustrated Parts List .....	5
5-1 (1)	Antenna Base Installation: Antenna Port .....	8
5-1 (2)	Antenna Base Installation: Antenna Bracket.....	9
5-2	Top Antenna Assembly Installation .....	10
5-3	Mounting Base Installation .....	12
5-4	Cable Diagram – For TD-1456/VRC.....	15

LIST OF TABLES

Table	Title	Page
3-1	Installation Times.....	3
4-1	Parts List for Installation Kit, Electronic Equipment MK-2867/VRC.....	4
4.2	Consumable Materials Required .....	6
4.3	Tools and Test, Measurement, and Diagnostic Equipment (TMDE) Required.....	6

## 0. GENERAL INFORMATION.

### 0.1 SCOPE.

This technical bulletin (TB) provides installation instructions for Installation Kit, Electronic Equipment MK-2867/VRC, commonly referred to as the Mounting Kit (MK).

The MK is used for installation of Frequency Hopping Multiplexer TD-1456/VRC at field locations. The information contained in this technical bulletin is the official authorization to perform the installation at the unit maintenance level.

#### NOTE

This TB is not an authorization for requisition or turn-in of vehicles or SINCGARS radio sets. This TB does not establish quantity or types of vehicles or radios assigned to units.

### 0.2 CONSOLIDATED INDEX OF ARMY PUBLICATIONS AND BLANK FORMS.

Refer to the latest issue of DA Pam 25-30 to determine whether there are new editions, changes, or additional publications pertaining to the equipment.

### 0.3 MAINTENANCE FORMS, RECORDS, AND REPORTS.

**0.3.1 Reports of Maintenance and Unsatisfactory Equipment.** Department of the Army forms and procedures used for equipment maintenance will be those prescribed by DA Pam 738-750, as contained in Maintenance Management Update. Air Force personnel will use AFR 66-1 for maintenance reporting and TO-00-35D54 for unsatisfactory equipment reporting. Navy personnel will report maintenance performed utilizing the Maintenance Data Collection Subsystem (MDCS) IAW OPNAVINST 4790.2, Vol 3 and unsatisfactory material/conditions (UR) IAW OPNAVINST 4790..2, Vol 2, chapter 17. Marine Corps maintains forms and procedures as prescribed by TM 4700-15/1.

**0.3.2 Reporting of Item and Packaging Discrepancies.** Fill out and forward SF 364 (Supply Discrepancy Report (SDR)) as prescribed in AR 735-11-2/DLAR 4140.55/SECNAVINST 4355.18/AFR 400-54/MCO 4430.3J.

**0.3.3 Transportation Discrepancy Report (TDR) (SF 361).** Fill out and forward Transportation Discrepancy Report (TDR) (SF 361) as prescribed in AR 55-38/NAVSUPINST 4610.33C/AFR 75-18/MCO P4610.19D/DLAR 4500.15.

### 0.4 DESTRUCTION OF ARMY ELECTRONICS MATERIEL.

Destruction of Army electronics materiel to prevent enemy use shall be in accordance with TM 750-244-2.

### 0.5 REPORTING EQUIPMENT IMPROVEMENT RECOMMENDATIONS (EIR).

**0.5.1 Army.** If your equipment needs improvement, let us know. Send us an EIR. You, the user, are the only one who can tell us what you don't like about your equipment. Let us know why you don't like the design or performance. Put it on an SF 368 (Product Quality Deficiency Report). Mail it to: Commander, US Army Communications-Electronics Command and Fort Monmouth, ATTN: AMSEL-LC-LEO-D-CS-CFO, Fort Monmouth, New Jersey 07703-5006. We'll send you a reply.

**0.5.2 Air Force.** Air Force personnel are encouraged to submit EIR's in accordance with AFR 900-4.

**0.5.3 Navy.** Navy personnel are encouraged to submit EIR's through their local Beneficial Suggestion Program.

**0.5.4 Marine Corps.** QDR shall be reported on SF 368 in accordance with MCO P4855.10, Product Quality Deficiency Report Manual. Submit to Commanding General, Marine Corps Logistics Base (Code 850), Albany, Georgia 31704-5000.

THIS PAGE INTENTIONALLY BLANK



## 1. PURPOSE OF INSTALLATION.

Installation Kit, Electronic Equipment MK-2867/VRC, herein referred to as the Mounting Kit (MK), prepares SINGARS-equipped vehicles for the installation of Frequency Hopping Multiplexer TD-1456/VRC.

## 2. END ITEM OR SYSTEM TO BE MODIFIED.

Not applicable.

## 3. APPLICATION TIMES.

**3.1 Time for Completion of Installation.** Using two people, a total of 2.5 work-hours is required. Typical vehicle downtime is 3.0 hours.

**3.2 Time for Installation of One Assembly or Component.** Table 3-1 lists the time required to install one component. All times have been rounded off to the nearest half hour. The sum of these items will not reflect the typical vehicle downtime.

ITEM	SECTION	TIME
Antenna AS-3900A/VRC	5.1	0.5
Mounting Base, Electrical Equipment MT-6845/VRC	5.2	1.5
Cables	5.3	1.0

## 4. PREPARATION FOR INSTALLATION.

**4.1 Preparation of Work Area.** Ensure that the site has adequate lighting and a power source.

**4.2 Preparation of Vehicle.** Inspect the vehicle for damage that could affect installation. Have any such damage repaired before installing MK.

**4.2.1 Items to be Removed.** Not applicable.

**4.2.2 Items to be Retained for Reuse.** Not applicable.

**4.3 Preparation of Installation Kit.** To prepare MK, unpack, inspect and check inventory.

**4.3.1 Precautions During Handling.** Observe these steps to prevent equipment damage.

- Keep dust cover in place on connectors.
- Do not disassemble or modify parts in MK unless authorized to do so.
- Keep mounting hardware covered and protected until needed.
- When exposed to moisture, rain or salt water, keep all parts dry to prevent corrosion.

**4.3.2 Unpack and Inspect Equipment.**

**4.3.2.1 Inspect Packaging for Evidence of Damage.** Report discrepancies as stated in para 0.3.3.

**4.3.2.2 Unpack and Inventory MK.** Refer to section 4.4. Report discrepancies as stated in para 0.3.2.

**4.3.2.3 Examine Each Item for Damage.** Report discrepancies as stated in para 0.3.2.

#### 4.4 Contents of Installation Kit

Refer to Table 4-1 and Figure 4-1 to identify and inventory MK parts.

Table 4-1. Parts List for Installation Kit, Electronic Equipment MK-2867/VRC				
NSN	ITEM DESCRIPTION AND PART NUMBER	QUANTITY IN MK	SMR CODE	FIGURE, ITEM NO.
5985-01-308-8988	Antenna, Vehicular AS-3900A/VRC (A3017899-2)	1	PAOOFA	4-1, 2
5305-00-847-1159	Screw, Cap, Hexagon (3/8-16 x 1-3/4 in) MS35307-365	4	PAOZZA	
5310-00-913-8881	Nut, Hexagon (3/8-16 in) MS51971-3	4	PAOZZA	4-1, 1
5310-00-061-1258	Washer, Lock, Internal/External-Toothed (3/8 in) MS45904-76	8	PAOZZA	
5310-00-889-2527	Washer, Lock, Internal/External-Toothed (5/16 in) MS45904-72	2	PAOZZA	
5306-00-225-9086	Bolt, Machine (5/16-24 x 5/8 in) MS90726-31 (Not Used)	1	PAOZZA	
5330-01-205-2864	Gasket (A3013655-1)	1	PAOZZA	
5975-01-430-3109	Mounting Base, Electrical Equipment MT-6845/VRC (A3214893-1)	1	PAOOFA	
5306-00-225-9089	Bolt, Machine (5/16-24 x 1 in) MS90726-34	4	PAOZZA	
5310-00-889-2527	Washer Lock, Internal/External-Toothed (5/16 in) MS45904-72	8	PAOZZA	
5310-00-880-7746	Nut, Hexagon (5/16-24 in) MS51968-5	4	PAOZZA	
5995-01-438-7824	Cable Assembly, Power Electrical, CX-13509/VRC (30 FT, 0 IN) (A3154857-5)	1	PAOZZA	
5995-01-226-2441	Cable Assembly, Radio Frequency, CG-3856/VRC (12 FT, 0 IN) (A3014032-14)	1	PAOZZA	4-1, 3
5995-01-437-8857	Cable Assembly, Radio Frequency, CG-3856/VRC (30 FT, 0 IN) (A3014032-16)	4	PAOZZA	4-1, 3
5995-01-439-1746	Cable Assembly, Special Purpose, Electrical CX-13528/VRC (30 FT, 0 IN) (A3210672-5)	2	PAOZZA	4-1, 4

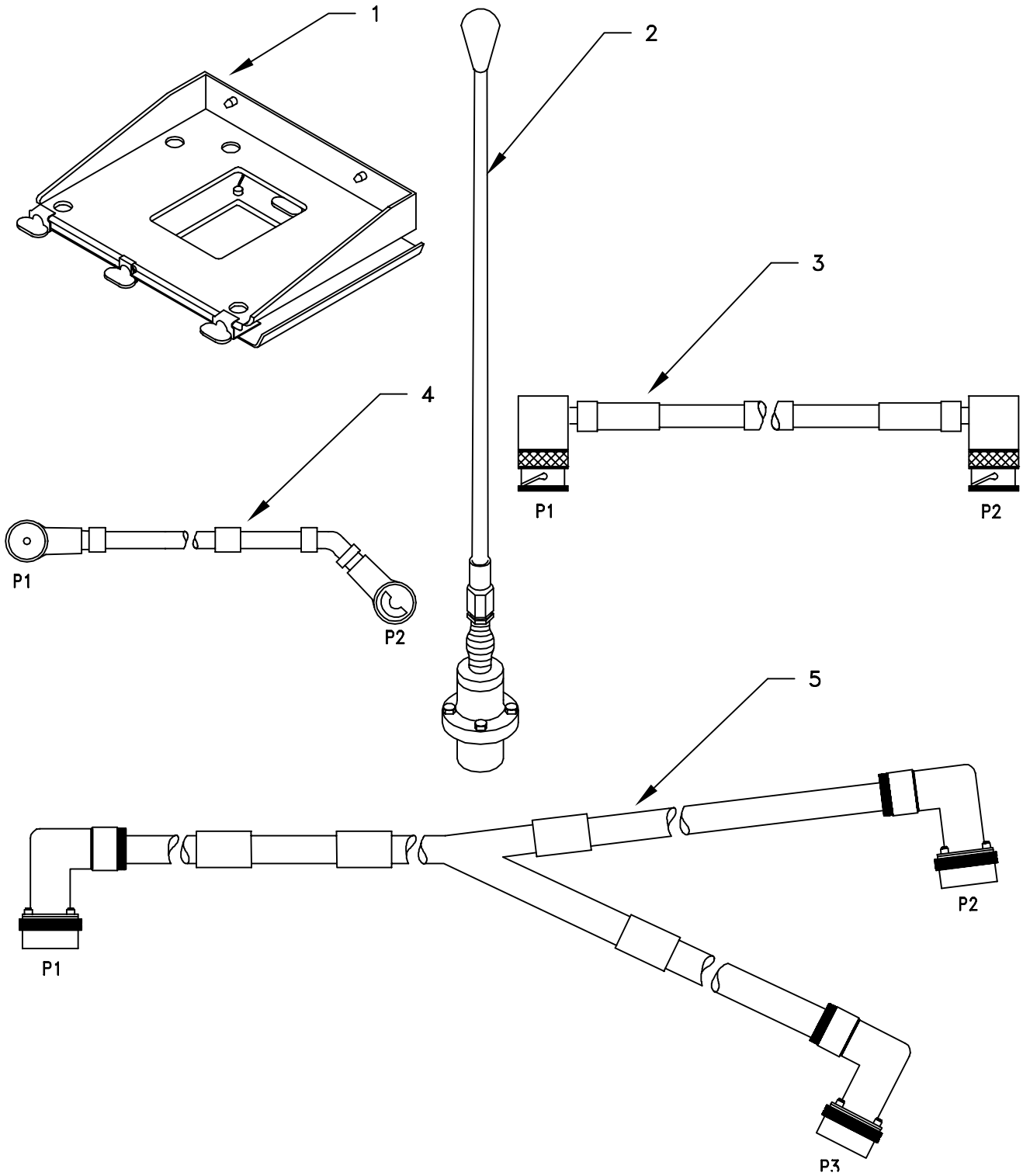

Figure 4-1. MK-2867/VRC Illustrated Parts List

**4.5 Consumable Materials Required.**

Table 4-3 lists materials required for installation but not supplied with the MK.

<b>Table 4.3. Consumable Materials Required</b>	
<b>NSN</b>	<b>NOMENCLATURE</b>
8040-01-331-7133	Adhesive-Sealant, Clear, RTV
6850-00-880-7616	Silicone Compound, MIL-S-8660
8030-00-292-1102	Conductive Anti-Seize Compound

**4.6 Tools and Test, Measurement, and Diagnostic Equipment (TMDE) Required.**

The following tools are needed for installation.

<b>Table 4.4. Tools and Test, Measurement, and Diagnostic Equipment (TMDE) Required</b>		
<b>NOMENCLATURE</b>	<b>NSN</b>	<b>QUANTITY</b>
Radio Sets*		2
Frequency Hopping Multiplexer*		1
Electric Grinder (or equivalent)		1
Pocket Knife, Electrician's	5110-00-240-5943	1
Screwdriver, No. 2 Point Phillips, 4 in	5120-00-234-8913	1
Screwdriver, 1/4 in Flat blade, 4 in	5120-00-222-8852	1
Pliers, Round Nose	5120-00-240-6172	1
Pliers, Diagonal Cutting	5110-00-965-0974	1
Wrench, Open/Box:		
3/8 in	5120-00-228-9504	1
1/2 in	5120-00-228-9506	1
9/16 in	5120-00-228-9507	1
Handle, Socket Wrench:		
Socket	5120-00-240-5364	1
3/8 in	5120-00-227-6702	1
1/2 in	5120-00-237-0977	1
9/16 in	5120-00-227-6704	1

\* Use radio sets and frequency hopping multiplexer issued with your vehicle if available.

## 5. INSTALLATION PROCEDURES.

This section describes where and how to install MK items in the vehicle. When installing MK equipment, be sure to read and follow instructions and illustrations carefully.

### 5.1 Installation of Antenna, Vehicular, AS-3900A/VRC (antenna).

**5.1.1 Installation of Antenna Base.** The antenna base can be installed on either an antenna bracket or antenna port. Use steps a through d to install antenna base on antenna port and steps e through h to install antenna base on antenna bracket.

ITEM	ACTION	REMARKS
<b>NOTE</b>		
Apply a thin coat of adhesive-sealant to both sides of each internal/external -toothed (IET) washer during installation and to the area of contact where IET washer is to be placed.		
a. Gasket (3).	Apply thin coat of silicone compound to both sides. Place on antenna port and align with mounting holes. See Figure 5-1 (1).	
b. Antenna base (7).	Place on top of gasket (3) and antenna port; then align mounting holes.	
c. Four cap screws (1) and four internal/external-toothed (IET) washers (2).	Install and secure to antenna base (7) and antenna port.	Tools: 9/16 in socket.
d. Ground strap (5), hex-head tapping screw (6) and two IET washers (4).	Install and secure to an existing grounding point.	Tools: 1/2 in socket.
e. Gasket (4)	Apply thin coat of silicone compound to both sides. Place on antenna bracket and align with mounting holes. See Figure 5-1 (2).	
f. Antenna base (1).	Place on top of gasket (4) and antenna bracket; then align mounting holes.	
g. Four cap screws (2), eight internal/external toothed (IET) washers (3) and four nuts (5).	Install and secure to antenna base (1) and antenna bracket.	Tools: 9/16 in socket and 9/16 in open/box wrench.
h. Ground strap (6), two internal/external toothed (IET) washers (6) and existing bolt	Install and secure to mounting hole in existing antenna bracket and mounting surface.	Tools: 1/2 in socket.

5.1.1 Installation of Antenna Base. Continued.

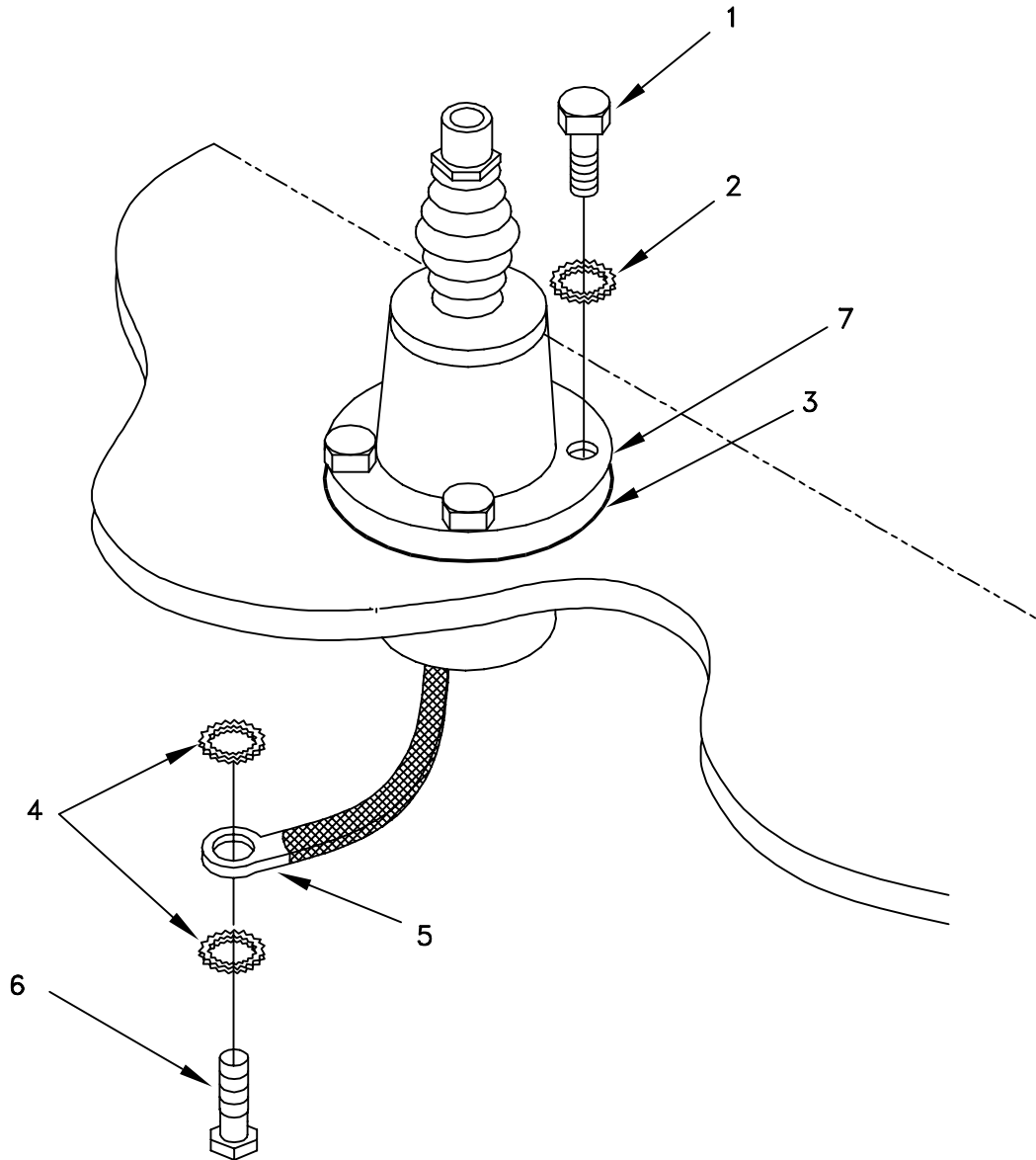

- 1. CAP SCREW (3/8-16 x 1 3/4 IN)
- 2. IET WASHER (3/8 IN)
- 3. GASKET
- 4. IET WASHER (5/16-IN)
- 5. GROUND STRAP

- 6. TAPPING SCREW (5/16-18 x 3/4 IN)
- 7. ANTENNA BASE

Figure 5-1 (1). Antenna Base Installation: Antenna Port

## 5.1.1 Installation of Antenna Base. Continued.

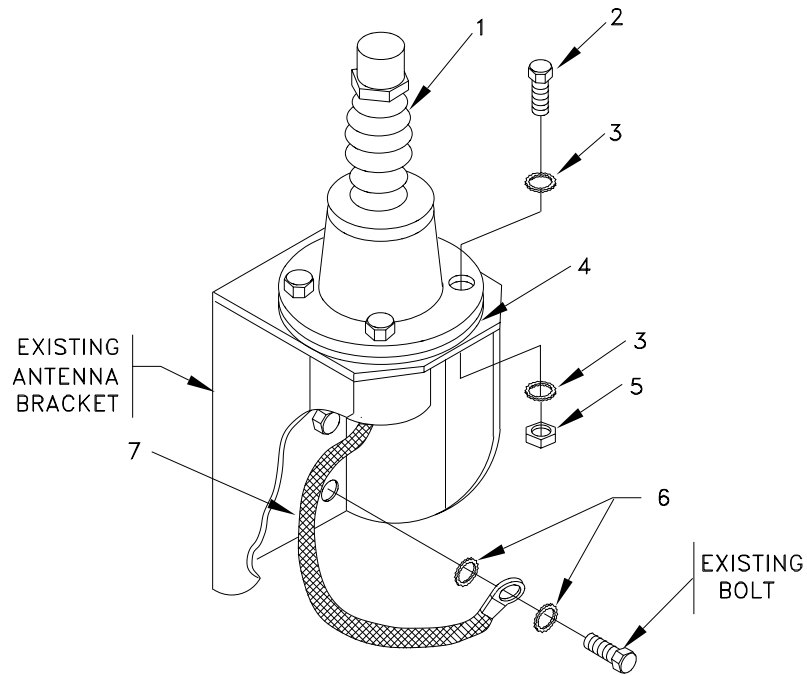

1. ANTENNA BASE
2. CAP SCREW (3/8-16 X 1 3/4 IN)
3. IET WASHER (3/8 IN)
4. GASKET
5. NUT (3/8-16 IN)
6. IET WASHER (5/16 IN)
7. GROUND STRAP

Figure 5-1 (2). Antenna Base Installation: Antenna Bracket

**5.1.2 Installation of Top Antenna Assembly.** The top portion of the antenna includes a lower element and an upper element (with installed cap). Use the following procedure to assemble, install and tie down all antennas.

ITEM	ACTION	REMARKS
a. Antenna elements (1, 2.)	Apply silicone compound to element threads and assemble. See Figure 5-2.	
b. Antenna element (2).	Install and hand tighten to antenna base (3).	
c. Lock wire (4).	Install to antenna element (2) and antenna base (3). See Figure 5-2, Detail A.  Cut and remove excess wire with diagonal cutting pliers.	
d. Fiber rope assembly (5).	Attach clip to antenna element (1). Tie rope to vehicle to position antenna in desired location. See Figure 5-2, Detail B.	

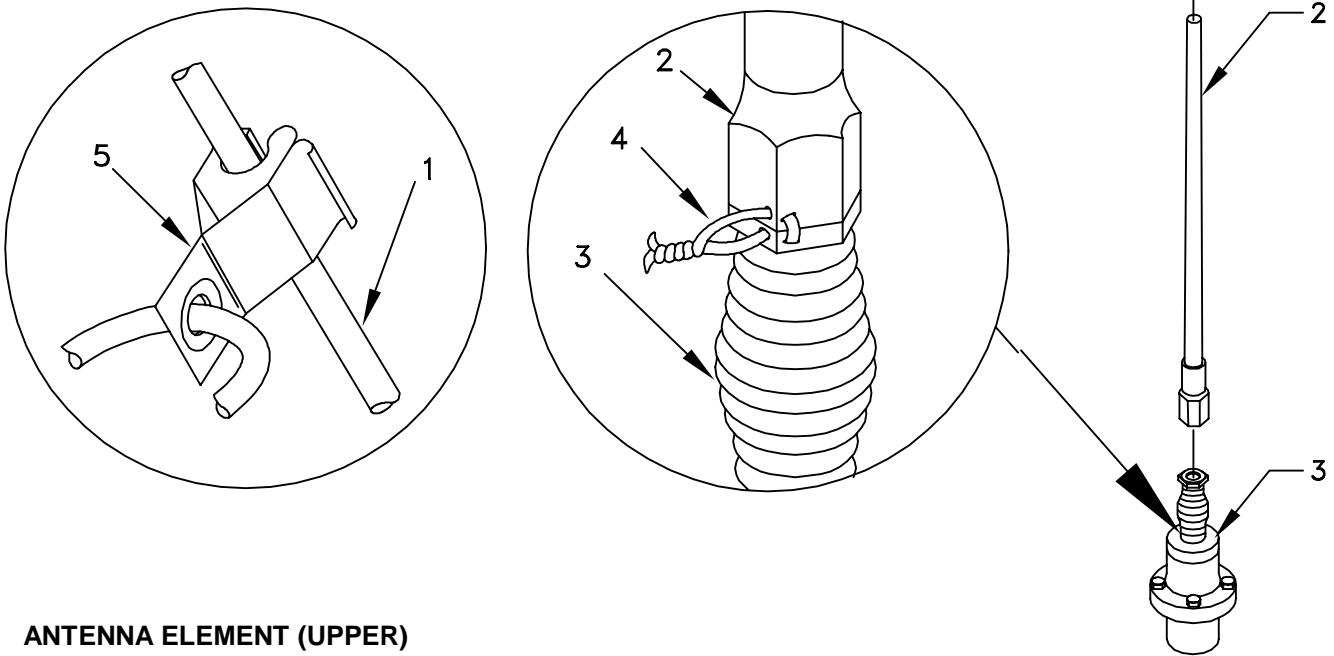

- 1. ANTENNA ELEMENT (UPPER)
- 2. ANTENNA ELEMENT (LOWER)
- 3. ANTENNA BASE
- 4. LOCK WIRE
- 5. FIBER ROPE ASSEMBLY

**Figure 5-2. Top Antenna Assembly Installation**



**5.2 Installation of Mounting Base, Electrical Equipment MT-6845/VRC (mounting base).** Remove and retain attaching bag of 5/16 mounting hardware. To insure good electrical grounding, any rust, corrosion or paint around mounting holes in mounting plate should be removed before installing the mounting base. See Figure 5-3 and perform the following steps.

ITEM	ACTION	REMARKS
<b>NOTE</b>		
Apply a thin coat of adhesive-sealant to both sides of each internal/external-toothed (IET) washer during installation, and to the area of contact where IET washer is to be placed.		
a. Mounting base (1).	Place on equipment shelf and use as template to mark four (4) each mounting holes.	
b. Mounting holes.	Drill four (4) each 11/32 diameter holes marked in step a.	Tools: Electric drill and 11/32 in drill bit.
c. Mounting base (1) and existing mounting shelf.	Remove a 2" square area of paint on the underside of the mounting base (1) around left front and rear mounting holes. Remove a 2" square area of paint on the existing mounting shelf around the mounting holes drilled in step b. that mate with left front and rear mounting holes of mounting base (1). Clean the paint removed areas and apply a thin coat of conductive anti-seize compound.	Tools: Electric grinder or equivalent.
d. Two outer thumbscrews (4).	Turn ccw until both sets of threads have cleared center of holes.	
e. Mounting base (1).	Align four holes with hole pattern drilled in step b.	
f. Four machine bolts (6), eight internal/external-toothed (IET) washers (3) and four nuts (2).	Install and secure to mounting base (1) and mounting shelf. See Figure 5-3.	Tools: 1/2 in socket and 1/2 in open/box wrench.
g. Two outer thumbscrews (4).	Tighten and secure to rim clenching clamps (5) and mounting base (1).	

5.2 Installation of Mounting Base, Electrical Equipment MT-6845/VRC (mounting base). Continued.

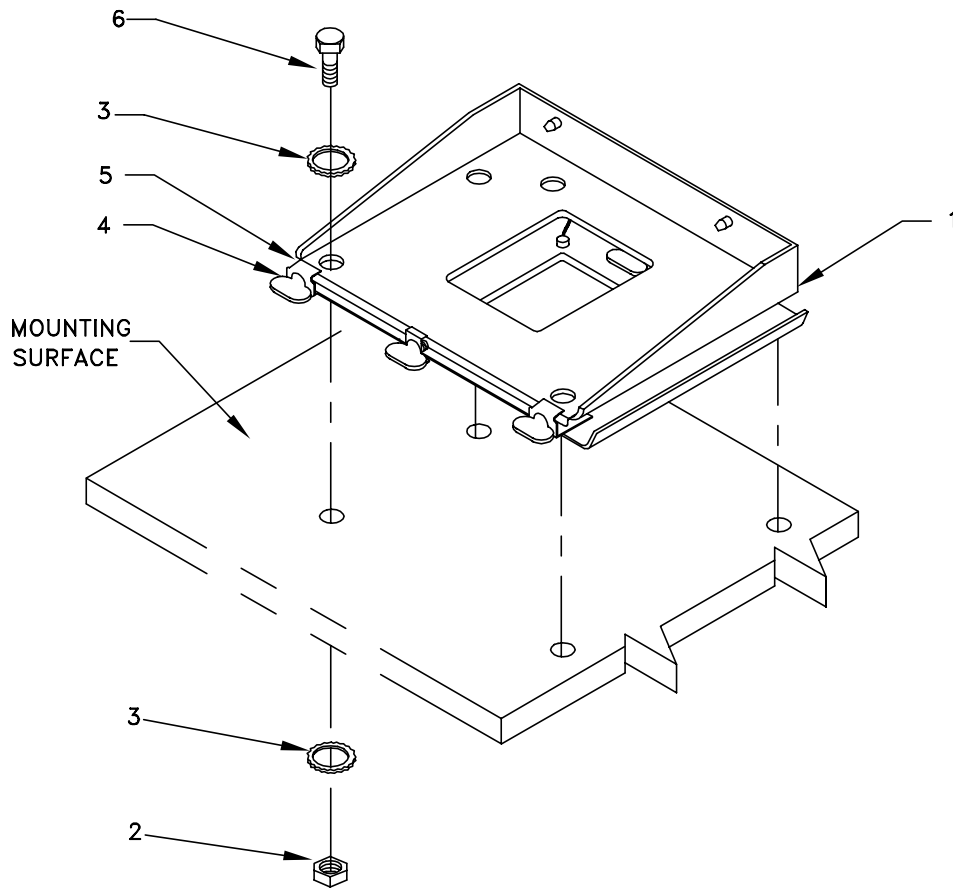

- 1. MOUNTING BASE
- 2. NUT (5/16-24 IN)
- 3. IET WASHER (5/16 IN)
- 4. THUMBSCREW
- 5. RIM CLENCHING CLAMP
- 6. MACHINE BOLT (5/16-24 x 1 IN)

Figure 5-3. Mounting Base Installation

**5.3 Installation of Cables.** To accomplish the installation, leave loop clamps and tiedown straps loose enough to adjust cable slack and allow easy adjustment of equipment. When installation is complete, tighten and secure all clamps, clips and tiedown straps.

---

**WARNING**

---

Make sure vehicle power source is positioned OFF or disconnected before installing cables.

ITEM	ACTION	REMARKS
a. RF cable (1) connector P1.	Connect and secure to antenna base (2) connector J1.	
b. RF cable (1).	Route along wall to left rear of mounting base (3) then forward and place connector P2 on top of mounting base (3).	
c. RF cables (4) connector P2.	Place connector P2 for each RF cable on top of mounting base (3) then route the cables behind existing installed communications equipment (as applicable) to the SINCGARS radio sets.	
d. SP cables (5) connector P2 and connector P3.	Place connector P2 and connector P3 for each SP cable on top of mounting base (3) then route the cables behind existing installed communications equipment (as applicable) to the SINCGARS radio sets.	
e. Power cable (6) connector P1.	Connect and secure to connector J3 of either SINCGARS MT-6353.	
f. Power cable (6).	Route behind existing installed communications equipment (as applicable) to mounting base (3).	
g. Power cable (6) connector P2.	Position on top of mounting base (3)	

**5.4 Post-Installation and Checkout.** After equipment is installed and cables are connected, perform the following steps.

ITEM	ACTION	REMARKS
a. Equipment.	Check for secure mounting. Check for loose parts, connectors, and mounting hardware.	
b. Cables.	Check for proper installation and connection of cables. See figure 5-4 for cable connections. Unused cables should be stowed in appropriate place inside the vehicle.	
c. Loop clamps.	Check that all have been properly installed and tightened.	
d. Protective covers.	Insure that all installed cables are covered when not in use or connected.	
e. Radio issued with vehicle.	Install and connect cables. See TM 11-5820-890-20-2 for installation and operational (OP) checks and instructions.	

5.4 Post-Installation and Checkout. Continued.

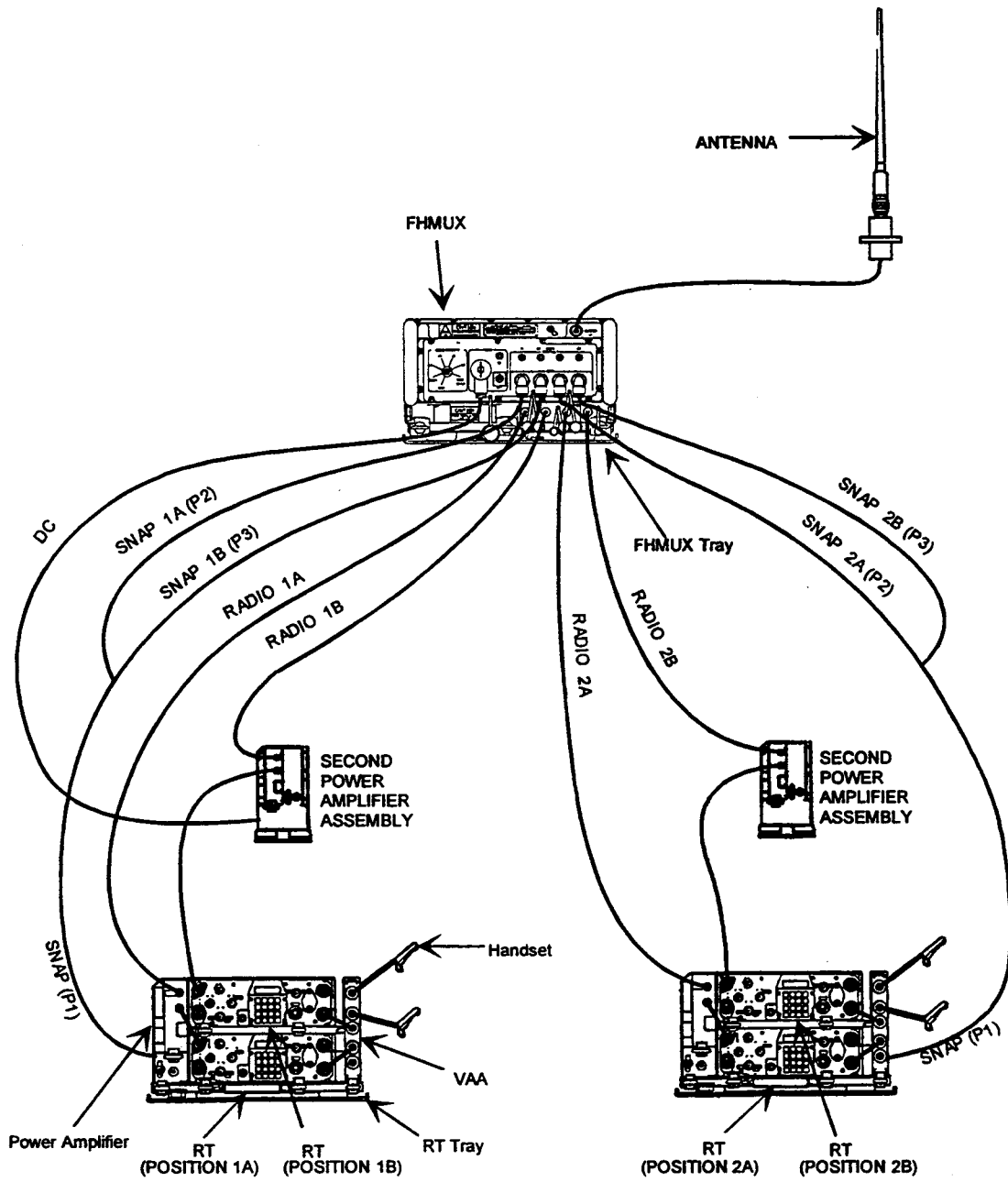

Figure 5-4. Cable Diagram: For TD-1456/VRC

**5.4 Post-Installation and Checkout.** Continued.

CABLE ASSEMBLY	FROM			TO		
	CABLE CONN.	UNIT	UNIT CONN.	CABLE CONN.	UNIT	UNIT CONN.
CX-13509/VRC (30 FT, 0 IN)	P2	TD-1456/VRC	Power	P1	MT-6353/VRC mounting base	J3
CX-13528/VRC (30 FT, 0 IN)	P2 (red)	TD-1456/VRC snap connector	1A	P1	AM-7239(C/D)/VRC radio set #1	J10
CX-13528/VRC (30 FT, 0 IN)	P3 (white)	TD-1456/VRC snap connector	1B			
CX-13528/VRC (30 FT, 0 IN)	P2 (orange)	TD-1456/VRC snap connector	2A	P1	AM-7239(C/D)/VRC radio set #2	J10
CX-13528/VRC (30 FT, 0 IN)	P3 (green)	TD-1456/VRC snap connector	2B			
CG-3856/VRC (12 FT, 0 IN)	P1	Antenna base	J1	P2	TD-1456/VRC	J1
CG-3856/VRC (30 FT, 0 IN)	P2 (red)	TD-1456/VRC RF connector	1A	P1	RF amplifier radio set #1	J1
CG-3856/VRC (30 FT, 0 IN)	P2 (white)	TD-1456/VRC RF connector	1B	P1	RF amplifier (MT-6353/VRC) radio set #1	J1
CG-3856/VRC (30 FT, 0 IN)	P2 (orange)	TD-1456/VRC RF connector	2A	P1	RF amplifier radio set #2	J1
CG-3856/VRC (30 FT, 0 IN)	P2 (green)	TD-1456/VRC RF connector	2B	P1	RF amplifier (MT-6353/VRC) radio set #2	J1

**Figure 5-4. Cable Diagram: TD-1456/VRC.** Continued.

## APPENDIX A

### REFERENCES

---

DA PAM 25-30	Consolidated Index of Army Publications and Blank Forms (Contained on EM 0001)
DA PAM 710-2-1	Using Unit Supply System Manual Procedures as Contained in Unit Supply UPDATE
EM 0071	Radio, SINCGARS, Ground/Airborne
SB 11-131-2	Vehicular Radio Sets and Authorized Installations (SINCGARS)
TM 11-5820-890-10-1	Operator's Manual (ICOM Radio Sets) (Included in EM 0071)
TM 11-5820-890-10-3	Operator's Manual (Non-ICOM Radio Sets) (Included in EM 0071)
TM 11-5820-890-10-8	Operator's Manual (ASIP Radio Sets) (Included in EM 0071)
TM 11-5820-890-20-1	Unit Maintenance Manual (ICOM Radio Sets, Vol. 1) (Included in EM 0071)
TM 11-5820-890-20-2	Unit Maintenance Manual (ICOM Radio Sets, Vol. 2) (Included in EM 0071)
TM 11-5820-890-20-3	Unit Maintenance Manual Handbook (ICOM Radio Sets) (Included in EM 0071)
TM 11-5820-890-20P	Repair Parts and Special Tools List (Included in EM 0071)





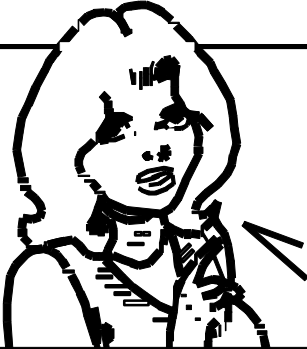

**SOMETHING WRONG WITH THIS PUBLICATION**

THEN ... JOT DOWN THE INFO ABOUT IT ON THIS FORM. CAREFULLY TEAR IT OUT. FOLD IT AND DROP IT IN THE MAIL.

FROM: (PRINT YOUR UNIT'S COMPLETE ADDRESS)  
 Commander  
 Stateside Army Depot  
 ATTN: AMSTA-US  
 Stateside, N.J. 07703-5007

DATE SENT  
 10 July 1975

PUBLICATION NUMBER TM 11-5840-340-20	PUBLICATION DATE 23 Jan 74	PUBLICATION TITLE Radar Set AN/PRC-76
---	-------------------------------	--

BE EXACT PIN-POINT WHERE IT IS				IN THIS SPACE TELL WHAT IS WRONG AND WHAT SHOULD BE DONE ABOUT IT:
PAGE NO	PARA GRAPH	FIGURE NO	TABLE NO	
2-25	2-28			<p>Recommend that the installation antenna alignment procedure be changed throughout to specify a 20 IFF antenna lag rather than 10.</p> <p>REASON: Experience has shown that with only a 10 lag, the antenna servo system is too sensitive to wind gusting in excess of 25 knots, and has a tendency to rapidly accelerate and decelerate as it hunts, causing strain to the drive train. Hunting is minimized by adjusting the lag to 20 without degradation of operation.</p>
3-10	3-3		3-1	<p>Item 5, Functional column. Change • 2 dB" to • 3 dB".</p> <p>REASON: The adjustment procedure for the TRANS POWER FAULT indicator calls for a 3 dB (500 watts) adjustment to light the TRANS POWER FAULT indicator.</p>
5-6	5-8			<p>Add new step f.1 to read, • Replace cover plate removed in step f.1, above."</p> <p>REASON: To replace the cover plate.</p>
		FO-3		<p>Zone C 3. On J1-2, change • +24 VDC" to • +5 VDC".</p> <p>REASON: This is the output line of the 5 VDC power supply. +24 VDC is the input voltage.</p>

TEAR ALONG DOTTED LINE

PRINTED NAME, GRADE OR TITLE AND TELEPHONE NUMBER SSG I. M. DeSpirito 999-1776	SIGN HERE 
---	---------------

FILL IN YOUR  
UNIT'S ADDRESS

FOLD BACK

DEPARTMENT OF THE ARMY

\_\_\_\_\_  
\_\_\_\_\_

OFFICIAL BUSINESS

PLEASE  
AFFIX  
STAMP  
POSTAGE  
REQUIRED

**SAMPLE**

Commander  
U.S. Army Communications-Electronics Command  
and Fort Monmouth  
ATTN: AMSEL-LC-LEO-D-CS-CFO  
Fort Monmouth, New Jersey 07703-5006

TEAR ALONG DOTTED LINE

# SOMETHING WRONG WITH THIS PUBLICATION

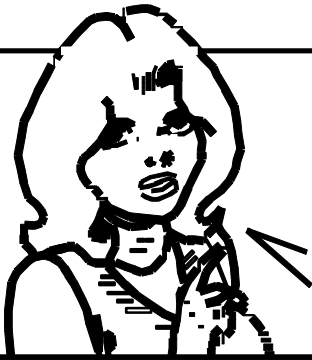

THEN ... JOT DOWN THE INFO ABOUT IT ON THIS FORM. CAREFULLY TEAR IT OUT. FOLD IT AND DROP IT IN THE MAIL.

FROM: (PRINT YOUR UNIT'S COMPLETE ADDRESS)

DATE SENT

PUBLICATION NUMBER

PUBLICATION DATE

PUBLICATION TITLE

BE EXACT PIN-POINT WHERE IT IS

IN THIS SPACE TELL WHAT IS WRONG AND WHAT SHOULD BE DONE ABOUT IT:

PAGE NO

PARA GRAPH

FIGURE NO

TABLE NO

TEAR ALONG DOTTED LINE

PRINTED NAME, GRADE OR TITLE AND TELEPHONE NUMBER

SIGN HERE

FILL IN YOUR  
UNIT'S ADDRESS

FOLD BACK

DEPARTMENT OF THE ARMY

\_\_\_\_\_  
\_\_\_\_\_

OFFICIAL BUSINESS

PLEASE  
AFFIX  
STAMP  
POSTAGE  
REQUIRED

TEAR ALONG DOTTED LINE

**Commander  
U.S. Army Communications-Electronics Command  
and Fort Monmouth  
ATTN: AMSEL-LC-LEO-D-CS-CFO  
Fort Monmouth, New Jersey 07703-5006**

# SOMETHING WRONG WITH THIS PUBLICATION



THEN ... JOT DOWN THE INFO ABOUT IT ON THIS FORM. CAREFULLY TEAR IT OUT. FOLD IT AND DROP IT IN THE MAIL.

FROM: (PRINT YOUR UNIT'S COMPLETE ADDRESS)

DATE SENT

PUBLICATION NUMBER

PUBLICATION DATE

PUBLICATION TITLE

BE EXACT PIN-POINT WHERE IT IS

IN THIS SPACE TELL WHAT IS WRONG AND WHAT SHOULD BE DONE ABOUT IT:

PAGE NO

PARA GRAPH

FIGURE NO

TABLE NO

TEAR ALONG DOTTED LINE

PRINTED NAME, GRADE OR TITLE AND TELEPHONE NUMBER

SIGN HERE

FILL IN YOUR  
UNIT'S ADDRESS

FOLD BACK

DEPARTMENT OF THE ARMY



OFFICIAL BUSINESS

PLEASE  
AFFIX  
STAMP  
POSTAGE  
REQUIRED

TEAR ALONG DOTTED LINE

**Commander  
U.S. Army Communications-Electronics Command  
and Fort Monmouth  
ATTN: AMSEL-LC-LEO-D-CS-CFO  
Fort Monmouth, New Jersey 07703-5006**

# SOMETHING WRONG WITH THIS PUBLICATION

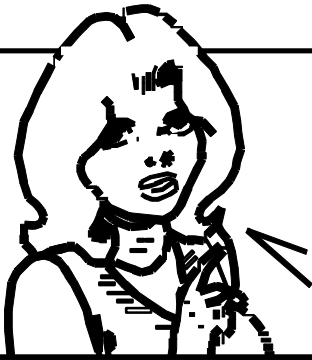

THEN ... JOT DOWN THE INFO ABOUT IT ON THIS FORM. CAREFULLY TEAR IT OUT. FOLD IT AND DROP IT IN THE MAIL.

FROM: (PRINT YOUR UNIT'S COMPLETE ADDRESS)

DATE SENT

PUBLICATION NUMBER

PUBLICATION DATE

PUBLICATION TITLE

BE EXACT PIN-POINT WHERE IT IS

IN THIS SPACE TELL WHAT IS WRONG AND WHAT SHOULD BE DONE ABOUT IT:

PAGE NO

PARA GRAPH

FIGURE NO

TABLE NO

TEAR ALONG DOTTED LINE

PRINTED NAME, GRADE OR TITLE AND TELEPHONE NUMBER

SIGN HERE

FILL IN YOUR  
UNIT'S ADDRESS

FOLD BACK

DEPARTMENT OF THE ARMY

\_\_\_\_\_  
\_\_\_\_\_

OFFICIAL BUSINESS

PLEASE  
AFFIX  
STAMP  
POSTAGE  
REQUIRED

TEAR ALONG DOTTED LINE

**Commander**  
**U.S. Army Communications-Electronics Command**  
**and Fort Monmouth**  
**ATTN: AMSEL-LC-LEO-D-CS-CFO**  
**Fort Monmouth, New Jersey 07703-5006**



By Order of the Secretary of the Army:

Official:

**PETER J. SCHOOMAKER**  
*General, United States Army*  
*Chief of Staff*

  
JOEL B. HUDSON  
*Administrative Assistant to the*  
*Secretary of the Army*  
0400808

DISTRIBUTION:

To be distributed in accordance with the initial distribution number (IDN) 362143 requirements for TB 11-5820-890-20-112.





**PIN: 080083-000**

This fine document...

Was brought to you by me:



## [Liberated Manuals -- free army and government manuals](#)

Why do I do it? I am tired of sleazy CD-ROM sellers, who take publicly available information, slap “watermarks” and other junk on it, and sell it. Those masters of search engine manipulation make sure that their sites that sell free information, come up first in search engines. They did not create it... They did not even scan it... Why should they get your money? Why are not letting you give those free manuals to your friends?

I am setting this document FREE. This document was made by the US Government and is NOT protected by Copyright. Feel free to share, republish, sell and so on.

I am not asking you for donations, fees or handouts. If you can, please provide a link to [liberatedmanuals.com](http://liberatedmanuals.com), so that free manuals come up first in search engines:

<A HREF=<http://www.liberatedmanuals.com/>>Free Military and Government Manuals</A>

- Sincerely  
Igor Chudov  
<http://igor.chudov.com/>
- [Chicago Machinery Movers](#)