

## ROUTINE

MWO effective date is 1 May 1992 and completion date is 20 October 1993

**MWO 9-2350-267-20-4**

# MODIFICATION WORK ORDER

---

## MODIFICATION OF M992 FIELD ARTILLERY AMMUNITION SUPPORT VEHICLE (FAASV) AUTOMATIC FIRE EXTINGUISHER SYSTEM (AFES) DECAL KIT

---

Headquarters, Department of the Army, Washington, DC

30 June 1992

### REPORTING OF ERRORS AND RECOMMENDING IMPROVEMENTS

You can help improve this MWO. If you find any mistakes or if you know of a way to improve these procedures, please let us know. Write a letter or complete and mail a DA Form 2028, Recommended Changes to Publications and Blank Forms, to U.S. Army Tank-Automotive Command, ATTN: AMSTA-MB, Warren, MI 48397-5000. A reply will be provided to you.

Approved for public release; distribution is unlimited.

1. **PURPOSE.** To provide a means for checking proper pin position of the Fire Extinguisher bottles.
2. **PRIORITY.** This modification is classified ROUTINE.
3. **END ITEMS OR SYSTEMS TO BE MODIFIED.** All M992 Field Artillery Ammunition Support Vehicles (FAASV), NSN 2350-01-110-4660, LIN C10908.
4. **MODULE (COMPONENTS, ASSEMBLIES, SUBASSEMBLIES, BOARDS AND CARDS) TO BE MODIFIED.** Not applicable.
5. **PARTS TO BE MODIFIED.** Not applicable.

**6. APPLICATION.**

a. Time Compliance Schedule. The effective date of this MWO is 1 May 1992 and its completion date is 20 October 1993.

b. Level of Maintenance Authorized to Apply the MWO. This modification will be accomplished by Unit Maintenance.

c. Work Force and Man-Hour Requirements.

WORK FORCE/SKILLS

MAN-HOURS

63D

1 HOUR

Total man-hours required to modify the Accessory Control Box Assembly, the Engine Test and Alarm Panel, and the Crew Test and Alarm Panel is one hour.

d. MWO's to be applied to or concurrently with this MWO. Not applicable.

**7. TECHNICAL PUBLICATIONS AFFECTED/CHANGED.**

- (1) TM 9-2350-267-20                      October 1985
- (2) TM 9-2350-267-20P                  January 1986
- (3) TM 9-2350-267-34P                  February 1986

**8. MWO KITS/PARTS AND THEIR DISPOSITION.**

a. Kit(s)/part(s) needed to apply the MWO. Kit, P/N 57K1051.

b. Contents of MWO kits. Refer to Table 1.

c. Bulk and expendable material: Rag, Wiping, P/N DDD-R-30; Detergent, MIL-D-16791.

d. Parts disposition. Not applicable.

Table 1. Kit Contents

<u>ITEM</u>	<u>QTY</u>	<u>NOMENCLATURE</u>	<u>PART NUMBER</u>	<u>CAGE</u>	<u>NSN</u>
1	1	Label, Warning	12376327-1	19207	7690-01-329-4633
2	1	Label, Warning	12376327-2	19207	7690-01-329-4632
3	1	Label, Warning	12376327-3	19207	7690-01-329-4631
4	1	Label, Warning	12376327-4	19207	7690-01-329-4630
5	1	Label, Warning	12376327-5	19207	7690-01-329-4629
6	1	Label, Warning	12376328-1	19207	7690-01-329-3490
7	1	Label, Warning	12376328-2	19207	7690-01-329-3489
8	1	Label, Warning	12376328-3	19207	7690-01-329-3488
9	2	Label, Warning	12376329	19207	7690-01-329-4627
10	2	Label, Warning	12376330	19207	7690-01-329-4628
11	1	Label, Warning	12376397	19207	7690-01-329-4634
12	1	Label, Warning	12268347	-	-
13	1	Label, Warning	12268539	-	-

**9. SPECIAL TOOLS: JIGS; TEST MEASUREMENT AND DIAGNOSTIC EQUIPMENT (TMDE), AND FIXTURES REQUIRED.** Not applicable.

**10. MODIFICATION PROCEDURES.**

Installation of Warning Labels 12376329 and 12376330 to Test and Alarm Panels.

**NOTE:** Surface area at all locations must be clean and dry before applying labels.

1. Place "MAINT" switch on Engine Test and Alarm Panel and Crew Test and Alarm Panel in the vertical position (AFES MAINT).
2. Clean the surface areas on the Engine and Crew Test and Alarm Panels with detergent.
3. Remove the protective backing from labels 12376329\* and 12376330\*, and position them on the Engine and Crew Test and Alarm Panels as shown in Figure 1.

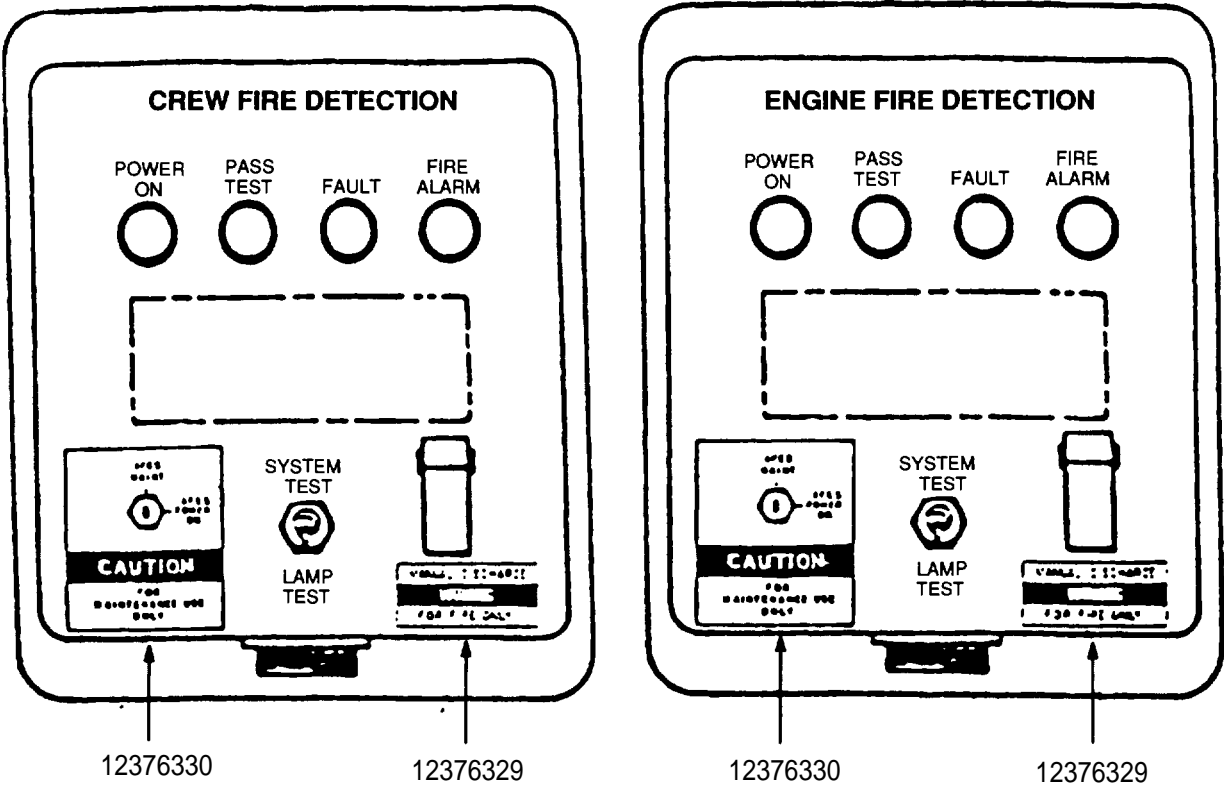

**Figure 1**

4. Using a dry rag, press decal into position. Start with the center and press outward to remove any air bubbles.
5. Return "MAINT" switch on Engine and Crew Test and Alarm panels to the horizontal position (AFES power on).

\*See page 13 for label reference identification.

Installation of Warning Labels 12376328-2 to APU Bulkhead.

6. Clean the surface area on the APU Bulkhead where the label is to be placed (reference Figure 2) with detergent.

7. Remove the protective backing from label 12376328-2\* and position on the APU Bulkhead as shown in Figure 2.

8. Using a dry rag, press decal into position. Start with center and press outward to remove any air bubbles.

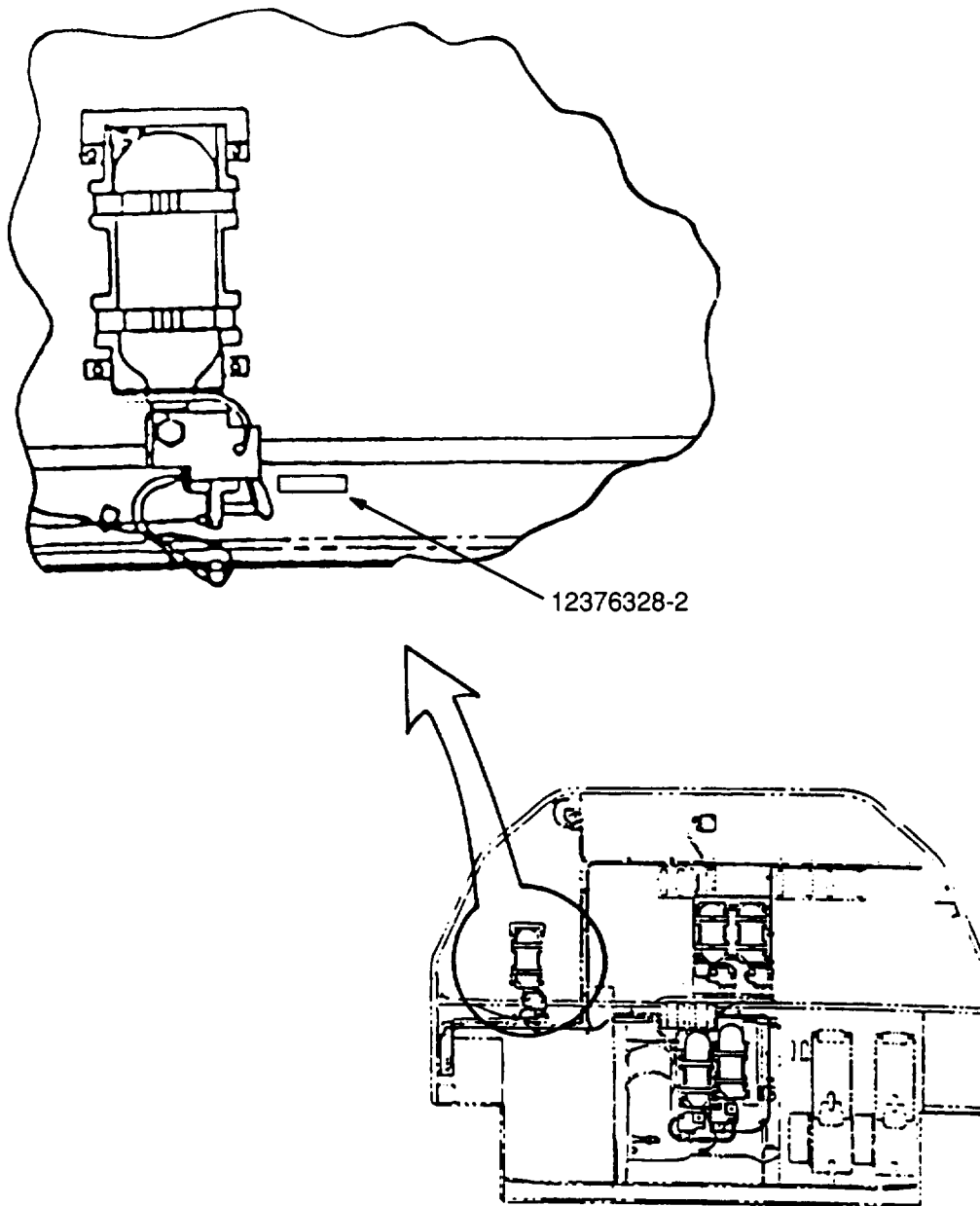

**Figure 2**

\*: See page 13 for label reference identification.

Installation of Warning Labels 12376327-1, 12376328-1, and 12376328-3 behind Projectile Rack

9. Move projectile rack toward rear of vehicle (reference TM 9-2350-267-10) to allow access to the AFES bottles.

10. Clean the surface area above each bottle with detergent.

NOTE: Steps 11 and 12 apply to labels 12376327-1\*, 12376327-2\*, 12376328-1\*, and 12376328-3\*.

11. Remove the protective backing from appropriate label and position as shown in Figure 3.

12. Using a dry rag, press decal into position. Start with center and press outward to remove any air bubbles.

13. Move projectile rack to forward position.

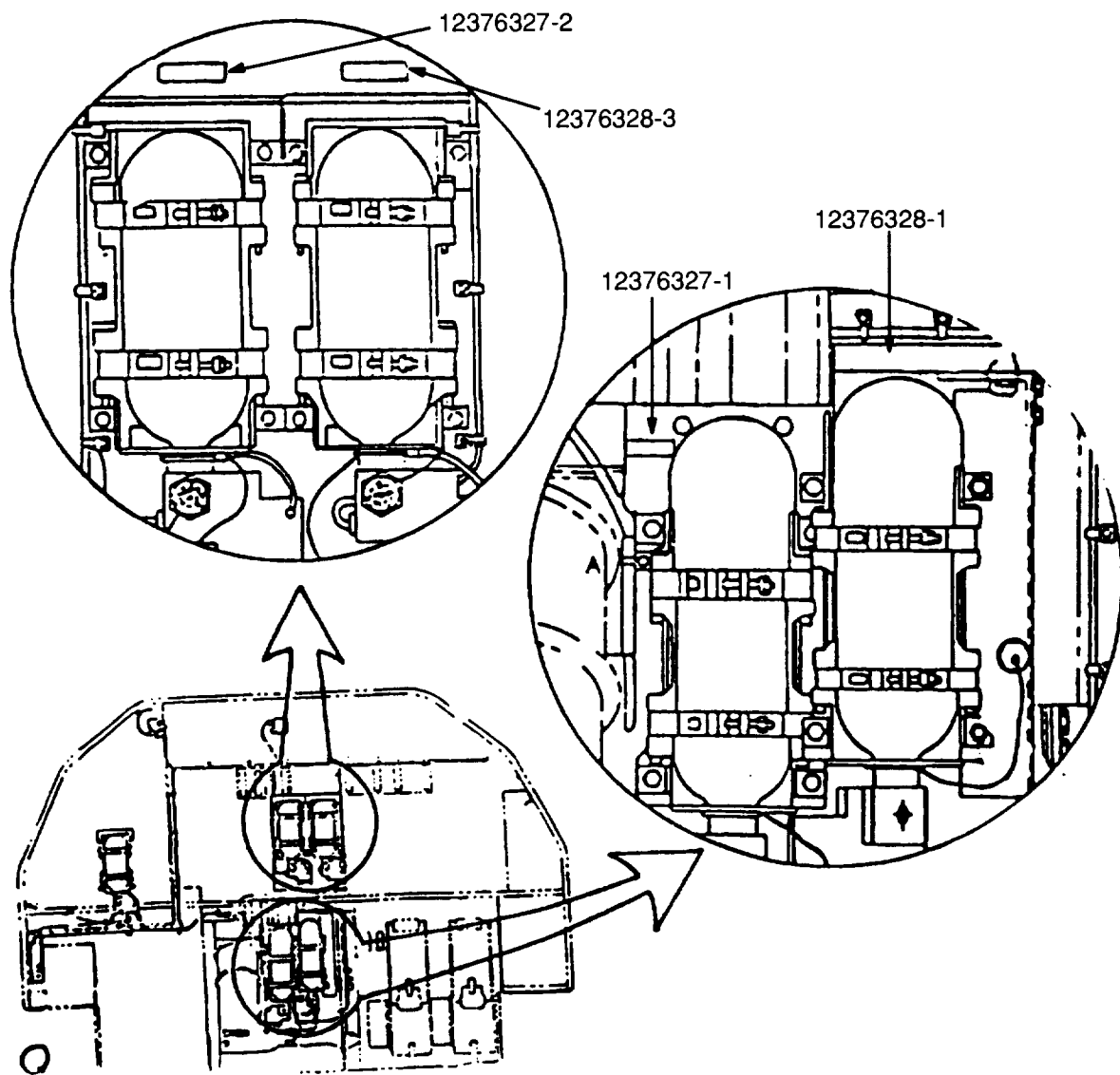

Figure 3

\*§ See page(s) 12 and 13 for label reference identification.

Installation of Warning Label 12376327-3 to Canister Racks.

14. Clean the surface below the bottle on the rear canister rack with detergent.
15. Remove the protective backing from label 12376327-3\* and position as shown in Figure 4.
16. Using a dry rag, press decal into position. Start with center and press outward to remove any air bubbles.

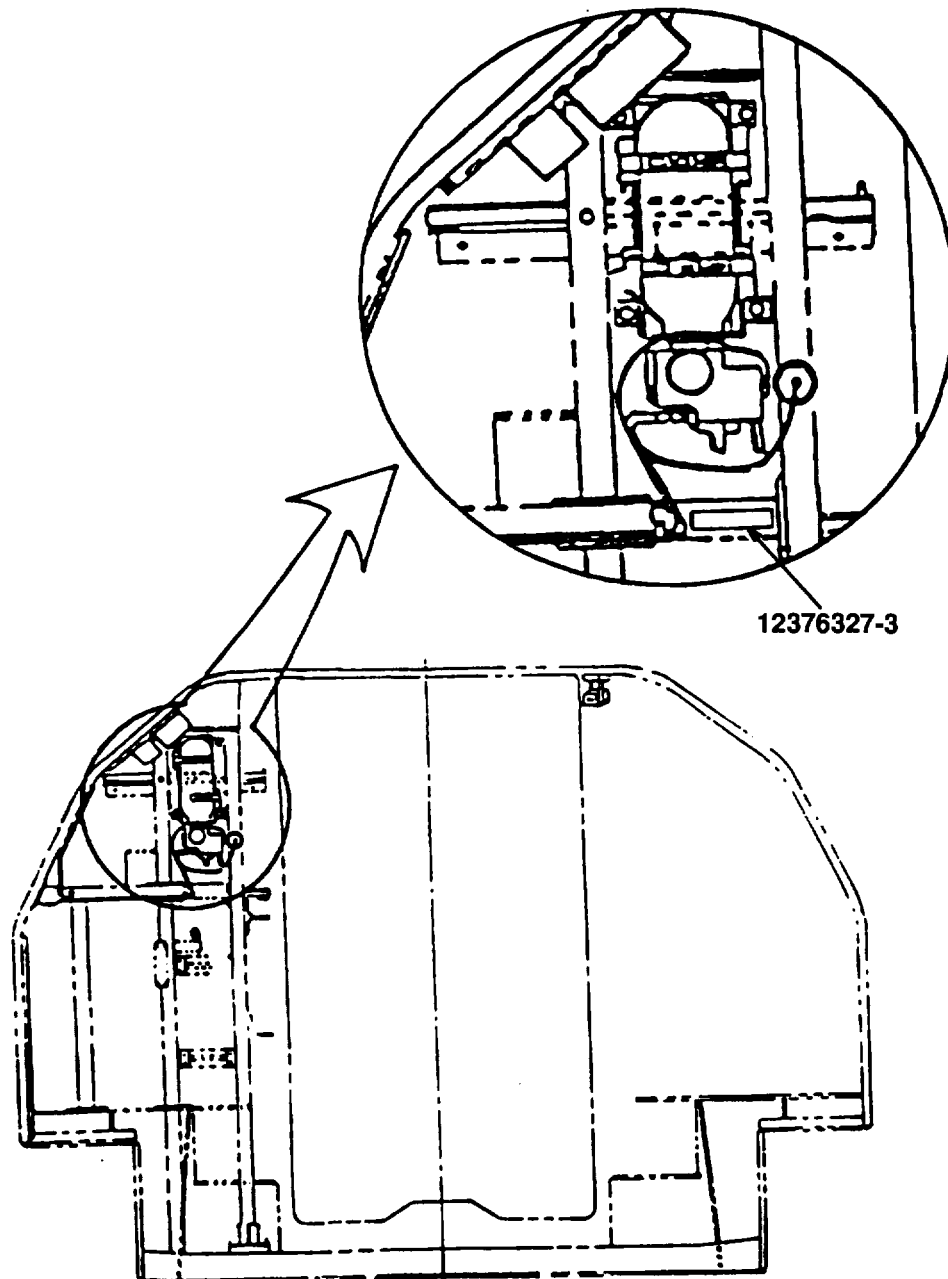

Figure 4

\*: See page 12 for label reference identification.

Installation of Warning Label 12376327-4 and 12376327-5 inside Fire Extinguisher Box at Rear of Vehicle.

NOTE: Labels 12376327-4\* and 12376327-5\* are for vehicles with serial numbers 345 and above. These labels are not necessary for vehicles with serial numbers 1-344 and are to be discarded.

17. Open the Fire Extinguisher Box at the rear of the vehicle and clean the surface area below each bottle with detergent.

18. Remove the protective backing from labels 12376327-4\* and 12376327-5\* and position as shown in Figure 5.

19. Using a dry rag, press decal into position. Start with center and press outward to remove any air bubbles.

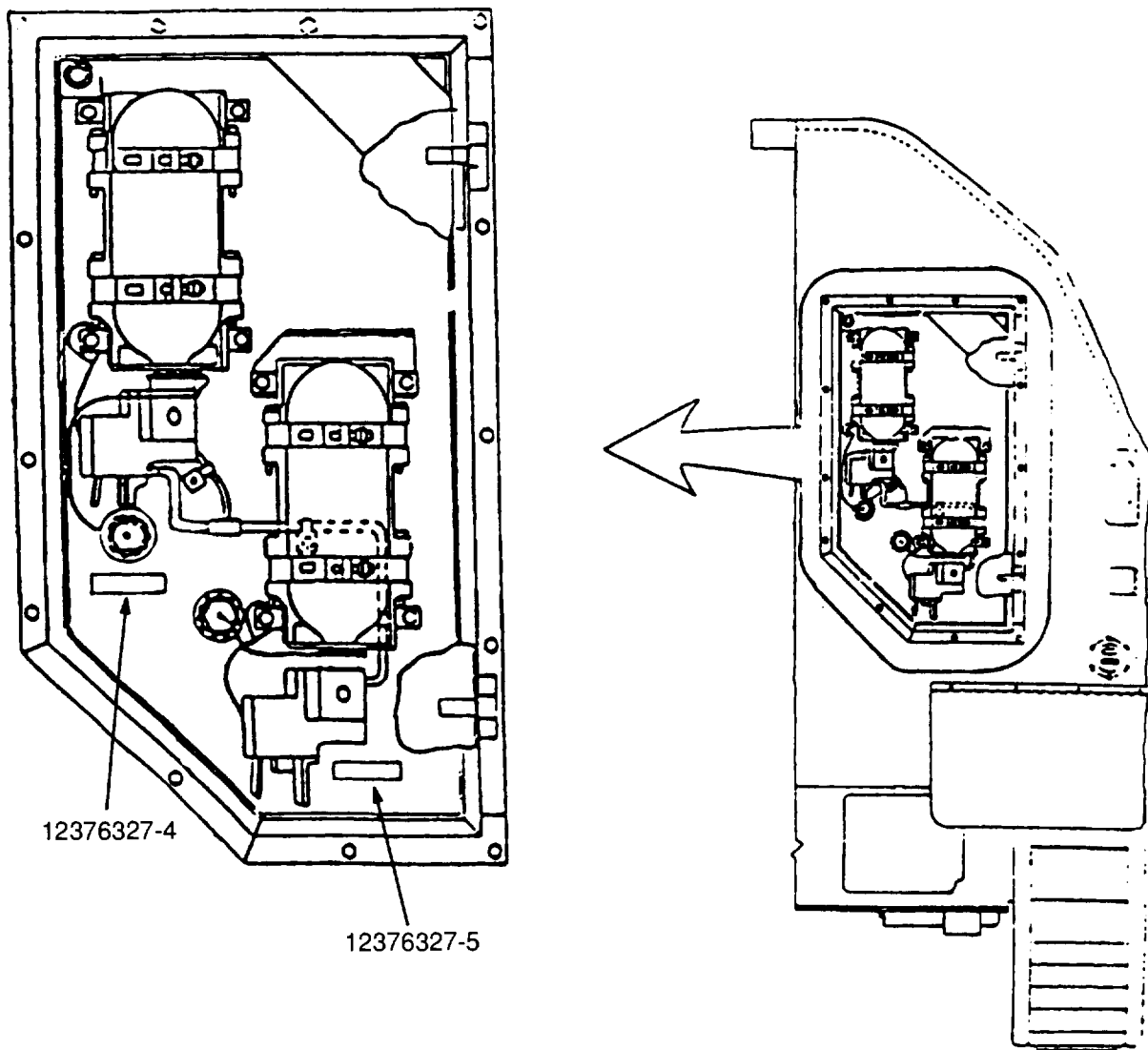

Figure 5

\*See page 12 for label reference identification.

Installation of Warning Label 12376397 inside Intake Grille at Front of Vehicle.

20. Open the intake grille at the front of the vehicle and lock into position.
21. Clean the surface area at the top right (as viewed from the front) of the intake grille with detergent (see Figure 6).
22. Remove the protective backing from label 12376397\* and position as shown in Figure 6.
23. Using a dry rag, press decal into position. Start with center and press outward to remove any air bubbles

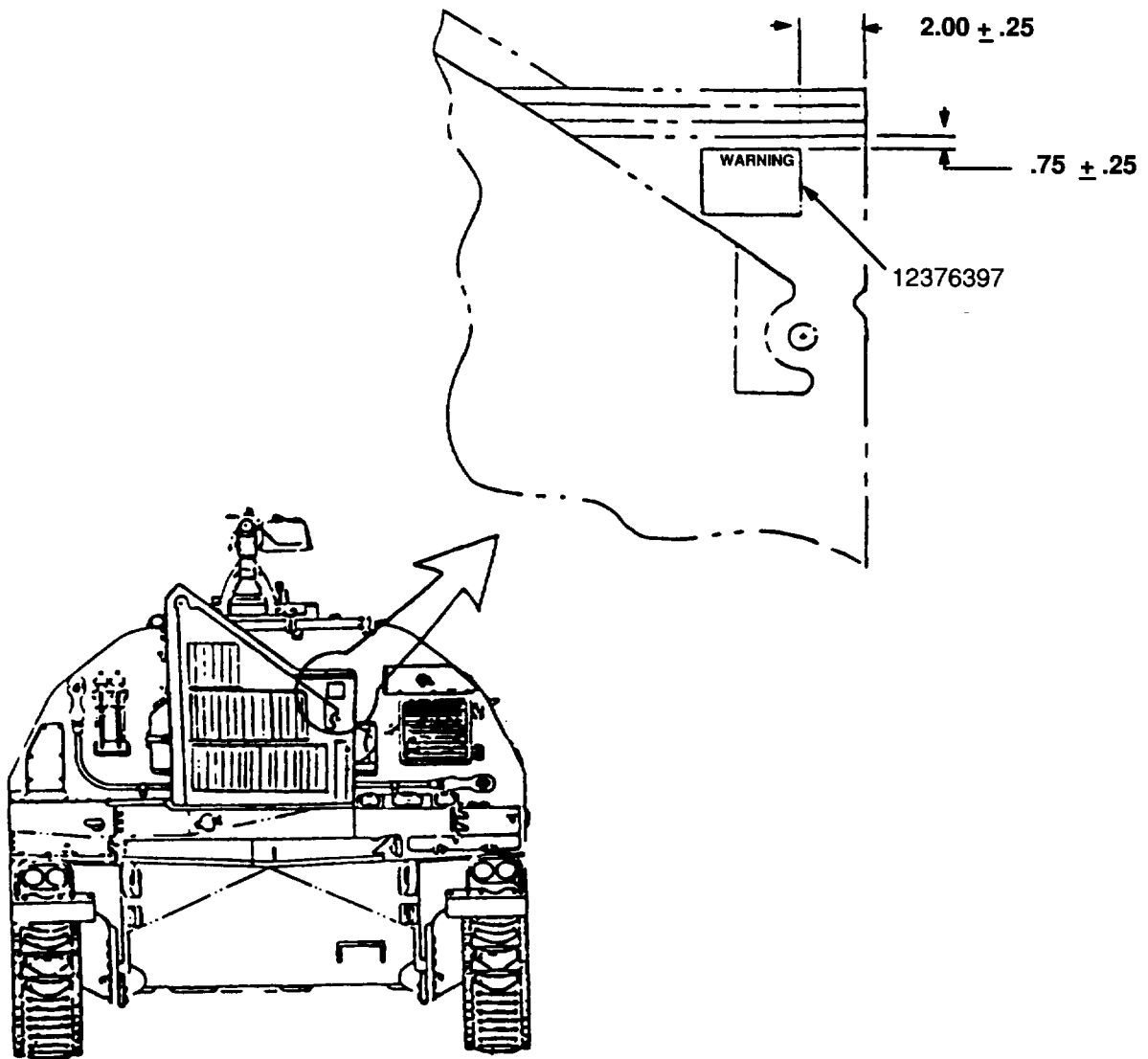

Figure 6

\*See page 13 for label reference identification.



Installation of Warning Label 12268347 to Accessory Control Box.

24. Clean surface of Accessory Control Box with detergent.

25. Remove the protective backing from label 12268347\* and position on the face of the Accessory Control Box Panel as shown in Figure 7.

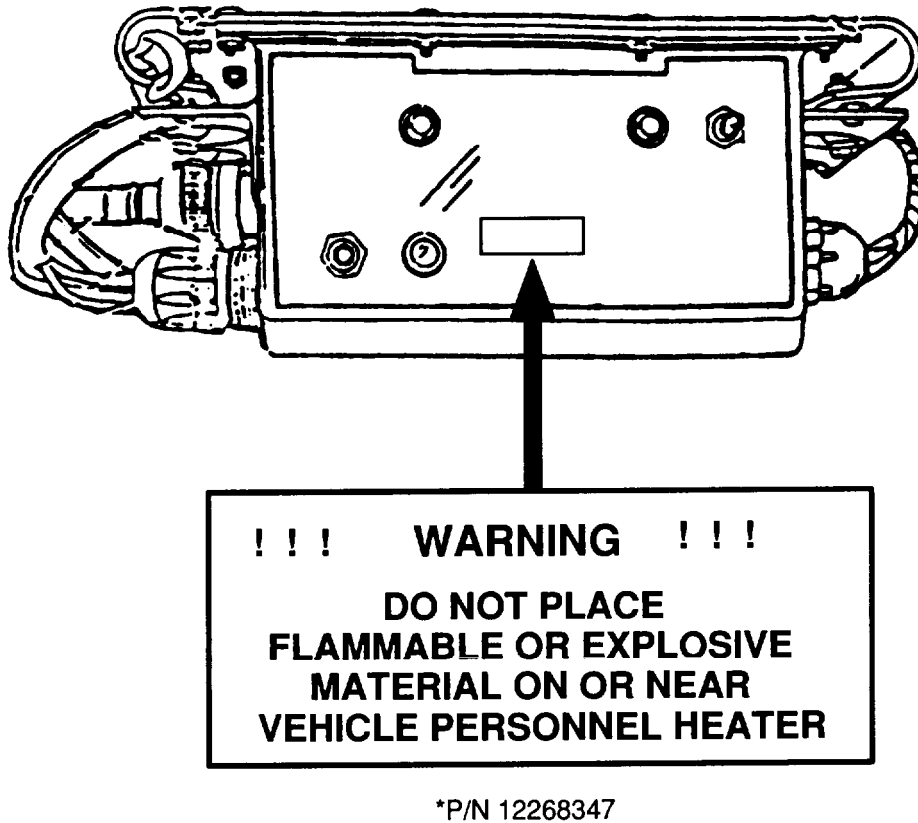

Figure 7

Installation of Warning Label 12268539 to the APU Bulk Head Wall.

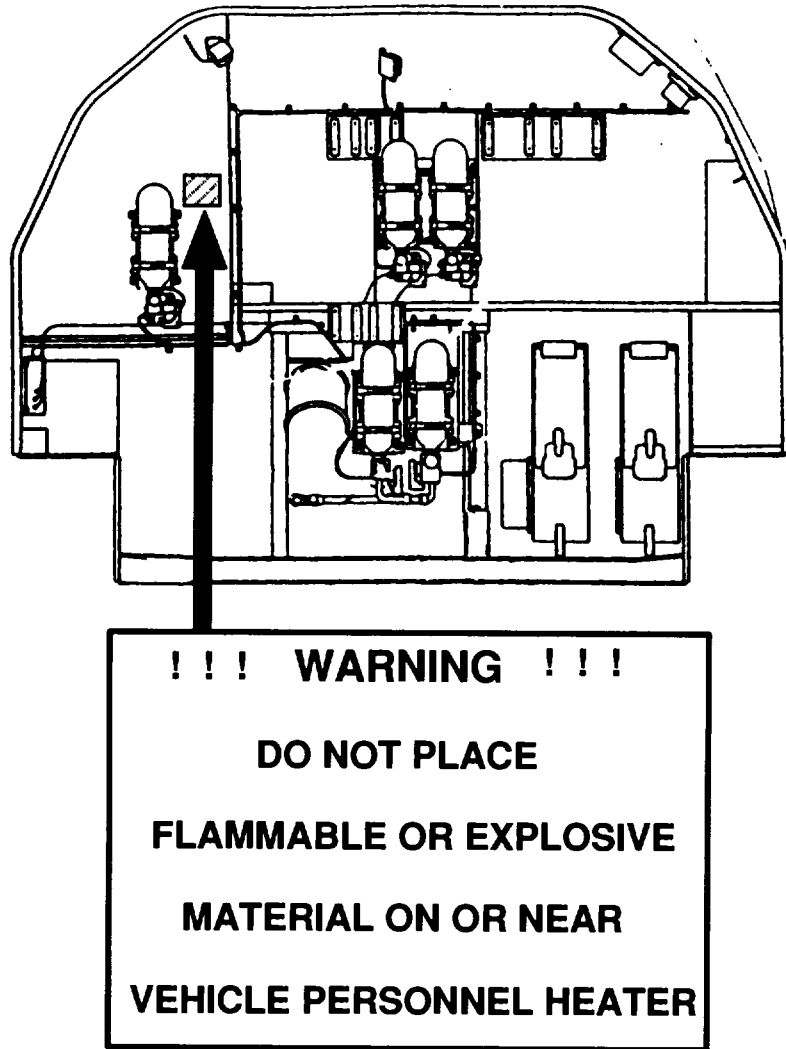

Figure 8

26. Clean the surface area of the APU Bulk Head wall where the label is to be placed.

**NOTE:** Surface must be clean and dry before applying the label.

27. Remove protective backing from label \* 12268539 and position on APU Bulk Head Wall as shown in Figure 8.

28. Using a dry rag, press decal into position. Start with center and press outward to remove any air bubbles.

11. **CALIBRATION REQUIREMENTS.** Not applicable.

12. **WEIGHT AND BALANCE DATA.** Not applicable.

13. **QUALITY ASSURANCE REQUIREMENTS.** Not applicable.

14. **RECORDING AND REPORTING OF THE MODIFICATION.**

a. Records and Reports.

(1) Refer to AR 750-10, DA Pam 738-750 and TB 9-1100-803-15 for detailed instructions on completing the following forms:

DA Form 5504 or 2407 - Maintenance Request  
DA Form 2408-5 - Equipment Modification Record  
DA Form 2409 - Equipment Modification Log

(2) Upon completion of DA Form 5504 or 2407, mail the NMP copy (#2) to:

Commander  
US Army Tank-Automotive Command  
ATTN: AMSTA-MRB  
Warren, MI 48397-5000

b. Marking Equipment. Specific instructions shall be provided for marking the modified item(s) and unless otherwise specified, a narrative description and illustration of the data plate and its location on the modified item shall be presented.

c. Identification Data. Information about the M992 Field Artillery Ammunition Support Vehicle (FAASV), CAGE, P/N and NSN changes on each affected item (end item, system, assembly) must be provided as part of MWO.

15. **MATERIEL CHANGE MANAGEMENT (MCM).** This MWO is authorized by Materiel Change Number 1-91-05-4321.

16. **MODIFICATION IDENTIFICATION.** Refer to paragraph 10.

AUTOMATIC FIRE EXTINGUISHING SYSTEM LABEL IDENTIFICATION

P/N 12376327-1

ENG NO. 1

**WARNING**

DO NOT REMOVE LOCKING PIN

P/N 12376327-2

CREW NO. 1

**WARNING**

DO NOT REMOVE LOCKING PIN

P/N 12376327-3

CREW NO. 2

**WARNING**

DO NOT REMOVE LOCKING PIN

P/N 12376327-4

CREW NO. 5

**WARNING**

DO NOT REMOVE LOCKING PIN

P/N 12376327-5

CREW NO. 6

**WARNING**

DO NOT REMOVE LOCKING PIN

P/N 12376328-1

**ENG NO. 2**

# WARNING

**DO NOT REMOVE LOCKING PIN DURING BOTTLE INSTALLATION  
REMOVE LOCKING PIN WHEN MANUAL CABLE CONNECTED  
INSTALL LOCKING PIN BEFORE BOTTLE REMOVAL**

P/N 12376328-2

**CREW NO. 3**

# WARNING

**DO NOT REMOVE LOCKING PIN DURING BOTTLE INSTALLATION  
REMOVE LOCKING PIN WHEN MANUAL CABLE CONNECTED  
INSTALL LOCKING PIN BEFORE BOTTLE REMOVAL**

P/N 12376328-3

**CREW NO. 4**

# WARNING

**DO NOT REMOVE LOCKING PIN DURING BOTTLE INSTALLATION  
REMOVE LOCKING PIN WHEN MANUAL CABLE CONNECTED  
INSTALL LOCKING PIN BEFORE BOTTLE REMOVAL**

P/N 12376329

**MANUAL DISCHARGE**

# WARNING FOR FIRE ONLY

P/N 12376330

**AFES  
MAINT**

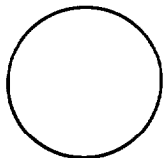

**AFES  
POWER  
ON**

## CAUTION

**FOR  
MAINTENANCE USE  
ONLY**

P/N 12376397

# WARNING

**DISCONNECT AFES  
THERMAL WIRE PRIOR  
TO REMOVING GRILLES  
AND  
REMOVING/INSTALLING  
THE POWER PACK**



By Order of the Secretary of the Army:

GORDON R. SULLIVAN  
*General, United States Army*  
*Chief of Staff*

Official:

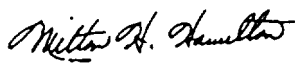

MILTON H. HAMILTON  
*Administrative Assistant to the*  
*Secretary of the Army*

02874

**Distribution:**

To be distributed in accordance with DA Form 12-37-E (Block 2339) requirements for MWO9-2350-267-20-4.





This fine document...

Was brought to you by me:



## [Liberated Manuals -- free army and government manuals](#)

Why do I do it? I am tired of sleazy CD-ROM sellers, who take publicly available information, slap “watermarks” and other junk on it, and sell it. Those masters of search engine manipulation make sure that their sites that sell free information, come up first in search engines. They did not create it... They did not even scan it... Why should they get your money? Why are not letting you give those free manuals to your friends?

I am setting this document FREE. This document was made by the US Government and is NOT protected by Copyright. Feel free to share, republish, sell and so on.

I am not asking you for donations, fees or handouts. If you can, please provide a link to [liberatedmanuals.com](http://liberatedmanuals.com), so that free manuals come up first in search engines:

<A HREF=<http://www.liberatedmanuals.com/>>Free Military and Government Manuals</A>

- Sincerely  
Igor Chudov  
<http://igor.chudov.com/>
- [Chicago Machinery Movers](#)