

**GENERATOR SET, DIESEL ENGINE-DRIVEN,
TACTICAL, SKID MTD, 15 KW, 3 PHASE, 4 WIRE,
120/208 AND 240/416 VOLTS**

(DOD MODEL MEP-004A 6115-00-118-1241)

(DOD MODEL MEP-104A 6115-00-118-1245)

(DOD MODEL MEP-113A 6115-00-118-1244)

References: TM 5-6115-464-12 and C9100-IL

REPORTING OF ERRORS

You can help improve this publication. If you find mistakes or if you know of a way to improve the procedures, please let us know. Your letter or DA Form 2028 (Recommended Changes to Publications and Blank Forms) should be mailed directly to: Commander, U.S. Army Troop Support Command, ATTN: AMSTR-MMTS, 4300 Goodfellow Blvd., St. Louis , MO63120- 1798. A reply will be furnished to you.

NOTES

This LO is for (C) Crew/Operator or Unit (O) maintenance. Lube intervals (on-condition or hard time) and task-hour times are based on normal hours of operation. Change the intervals if your lubricants are contaminated or if you are operating the equipment under adverse operating conditions. Lube more during constant use and less during inactive periods. Adequate preservation precautions must be taken during inactive periods.

WARNING

Dry cleaning solvent PD-680 Type II or equivalent used to clean parts is potentially dangerous to personnel and property. Avoid repeated and prolonged skin contact. Do not use near open flame or excessive heat. Flash point of solvent is 100°F - 138°F (38°C-60°C).

Clean parts with dry cleaning solvent PD-680 and dry before lubricating.

On-condition (OC) intervals for oil changes shall be determined by the Army Oil Analysis Program (AOAP) laboratory and shall be applied unless otherwise notified.

Hard time oil change intervals will be applied in the event AOAP laboratory support is not available.

Before you start your lube service:

ALWAYS

NEVER

- a. Clean parts before lubricating.
- b. Use the lubrication order as your guide.

- a. Use wrong type/grade lubricant.
- b. Use too much lubricant.

DISTRIBUTION STATEMENT A - Approved for public release; distribution is unlimited.

* The time specified is the time required to perform all services at the particular interval (on-condition or hard time).

*TOTAL TASK-HR		*TOTAL TASK-HR	
INTERVAL	TASK-HR	INTERVAL	TASK-HR
8	0.1	50H or 60D	0.6
100	0.1	1000	1.0

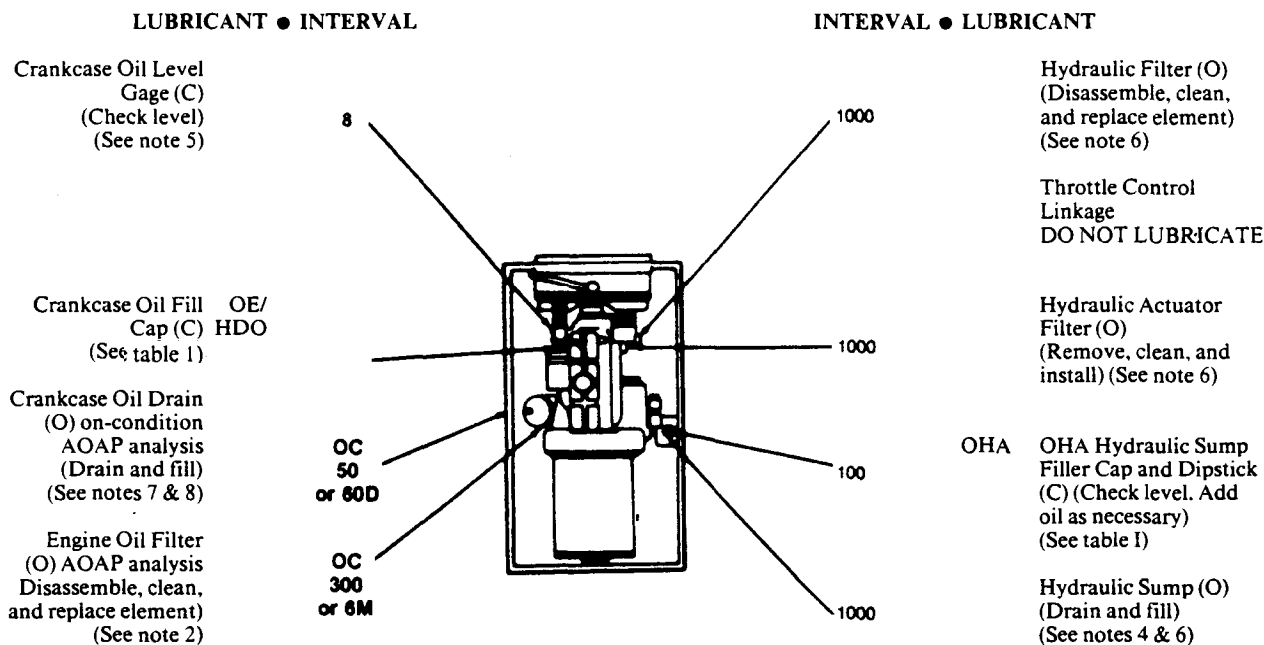

TABLE I. Lubricant Table for 15 KW Generator Set

Temperature Range	Lubricant Mil. Symbol (NATO Code) Specification	Capacity	Interval	Task-hour
-18°C to +49°C (zero to +120°F)	OE/HDO 15/40 (0-1236) MIL-L-2104	8 qts (7.6L)	300 hr	.6
-25°C to +40°C (-15°F to +40°F)	OE/HDO-10 (0-237) MIL-L-2104	8 qts (7.6L)	300 hr	.6
-10°C to +49°C (+15°F to +120°F)	OE/HDO-30 (0-238) MIL-L-2104	8 qts (7.6L)	300 hr	.6
-05°C to +49°C (+25°F to +120°F)	OE/HDO-40 (N/A) MIL-L-2104	8 qts (7.6L)	300 hr	.6
-57°C to +04°C (-70°F to +40°F)	OEA (0-183) MIL-L-46167	8 qts (7.6L)	300 hr	.6
-57°C to +49°C (-15°F to +120°F)	OEA MIL-H-4606B	4 qts (3.8L)	1000 hr	1.0

1. FOR OPERATION OF EQUIPMENT IN PROTRACTED COLD TEMPERATURES BELOW -10°F (-23°C). Remove lubricants prescribed in the key for temperatures above -10°F (-23°C). Clean parts with drycleaning SOLVENT (SD), type II or equivalent. Lubricate with lubricants specified in the key for temperatures below 0°F to -65°F.

2. OIL FILTER. Every 300 hours remove filter element, clean housing, install new element, fill crankcase, operate engine for 5 minutes, check for leaks, check crankcase oil level, and bring to FULL mark. Oil filter replacement interval shall align with on-condition AOAP or hard time oil change requirements. See notes 7 and 8.

3. OIL CAN POINTS. Every 100 hours lubricate the hinges, latches, control linkages, and all exposed adjusting threads with OE/HDO.

4. HYDRAULIC SUMP. To drain, remove hydraulic lines from actuator and drain oil into a suitable container. Replace hydraulic line, fill tank, and check level.

5. CRANKCASE. Crankcase level maybe checked with the engine in either a static or operating condition.

6. HYDRAULIC FILTER, HYDRAULIC ACTUATOR FILTER AND HYDRAULIC SUMP. Precise sets only.

7. CRANKCASE OIL. A sample of the oil shall be sent to an AOAP laboratory for analysis at an interval of 50 hours or 60 days. Refer to TB43-0210 for sampling requirements.

8. When AOAP laboratory support is not available, drain and refill crankcase oil and change the oil filter at 300 hours or 6 months.

9. For arctic operation refer to FM 9-207.

A copy of this Lubrication Order will remain with the equipment at all times; instructions contained herein are mandatory.

LO 9-6115454-12

By Order of the Secretary of the Army:

GORDON R. SULLIVAN
General, United States Army
Chief of Staff

Official:

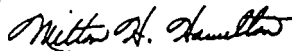

MILTON H. HAMILTON
Administrative Assistant to the
Secretary of the Army

00992

DISTRIBUTION:

To be distributed in accordance with DA Form 12-25E, (qty rqr block no. 4170)
DA Form 12-25A, (qty rqr block no. 0844 and 0845)

☆U.S. GOVERNMENT PRINTING OFFICE : 1995 386-730 (20306)

This fine document...

Was brought to you by me:



[Liberated Manuals -- free army and government manuals](#)

Why do I do it? I am tired of sleazy CD-ROM sellers, who take publicly available information, slap “watermarks” and other junk on it, and sell it. Those masters of search engine manipulation make sure that their sites that sell free information, come up first in search engines. They did not create it... They did not even scan it... Why should they get your money? Why are not letting you give those free manuals to your friends?

I am setting this document FREE. This document was made by the US Government and is NOT protected by Copyright. Feel free to share, republish, sell and so on.

I am not asking you for donations, fees or handouts. If you can, please provide a link to liberatedmanuals.com, so that free manuals come up first in search engines:

<A HREF=<http://www.liberatedmanuals.com/>>Free Military and Government Manuals

- Sincerely
Igor Chudov
<http://igor.chudov.com/>
- [Chicago Machinery Movers](#)