

LUBRICATION

L055-1925-204-12-7

ORDER

15 OCTOBER 1973 (Supersedes L055-3950-209-12 Dtd 1 DEC 64)

**TUG, HARBOR, DIESEL, 1200 H. P. STEEL, 100 FT DESIGN 3006
(HULL NUMBERS LT 1936 THRU LT 1977 AND LT 2202)**

Reference: FEDERAL SUPPLY CATALOG C9100-IL, L055-1925-204-12-1, 2, 3, 4, 5, 6, 8, TM55-1925-204-12 and TM55-1925-204-34

Intervals are based on normal hours of operations. Adjust to compensate for abnormal operations and severe conditions. During inactive periods, sufficient lubrication must be performed for adequate preservation.

Relubricate after exposure to salt water.

Clean fittings before lubricating.

Clean parts with SOLVENT, Dry-cleaning, Type II, (SD-2).
Dry before lubricating.

Lubricate points indicated by dotted arrow shafts on both sides of equipment.

Drain wet crankcases and gear boxes while the lubricant is still warm from previous use.

FOLD

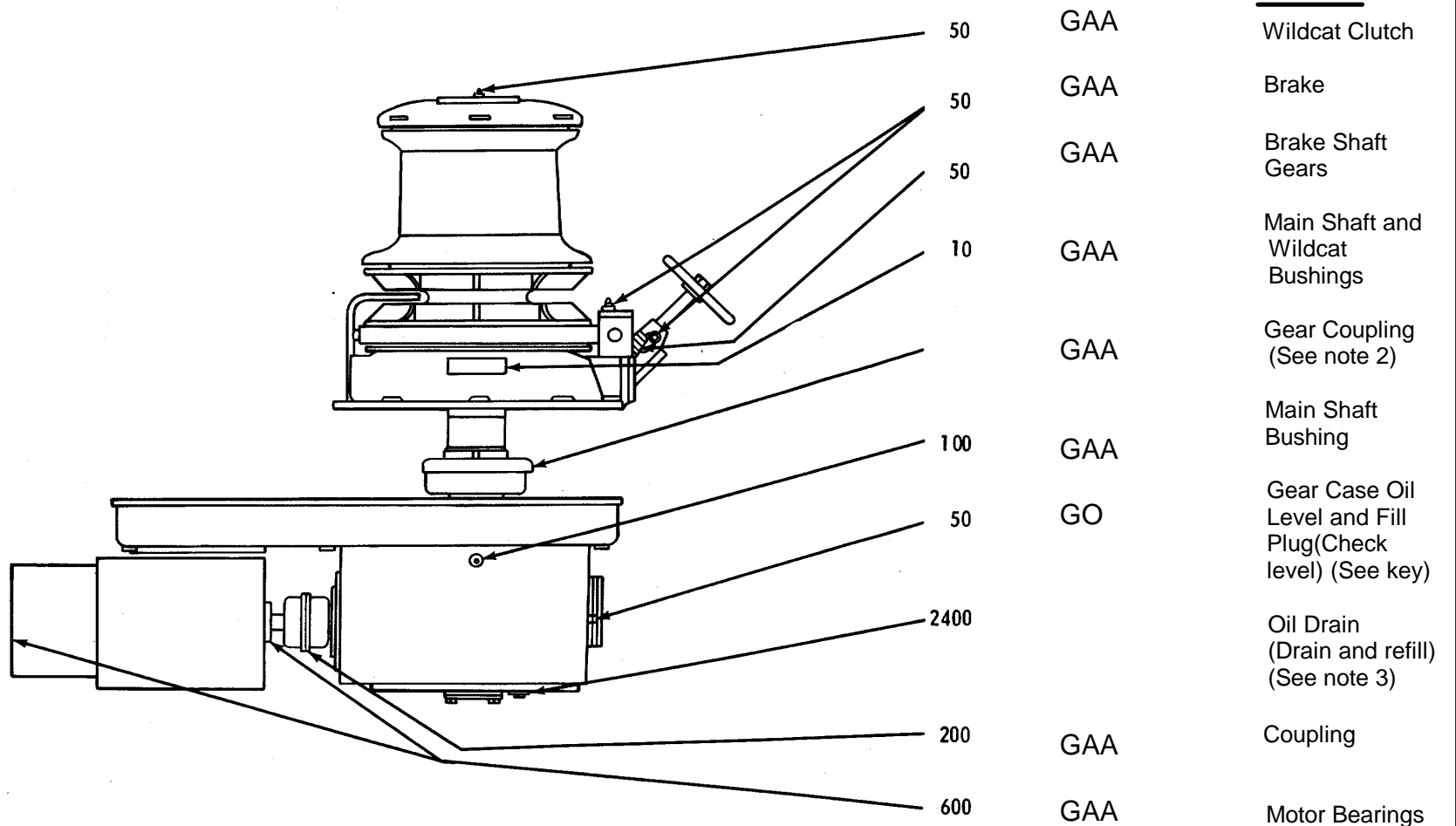

FOLD

CAPSTAN-WINDLASS, MODEL VEV-16

LUBRICANT · INTERVAL

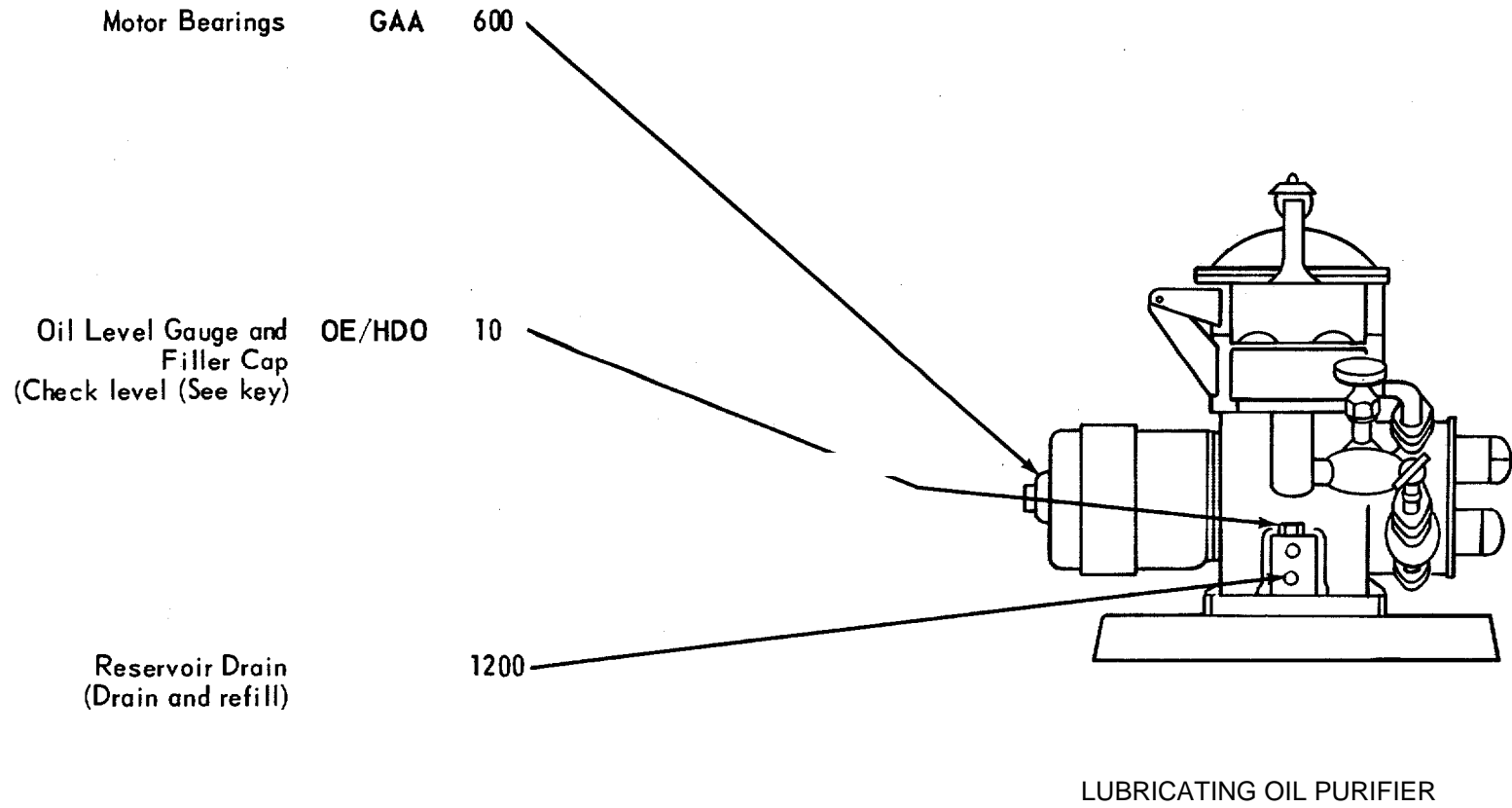

LUBRICATING OIL PURIFIER

FOLD

FOLD

-KEY-

LUBRICANTS	CAPACITY	EXPECTED TEMPERATURES			INTERVALS
		Above + 32° F	+ 40° F to -10° F	0° F to -65° F	
OE/HDO-LUBRICATING OIL, Engine					Intervals given are in hours of normal operation
Oil Purifier		OE/HDO 30	OE/HDO 30	OE/HDO 30	
OES-LUBRICATING OIL, Sub-zero		ALL TEMPERATURES			
GAA-GREASE, Auto & Artillery					
GO-LUBRICATING OIL, Gear Sub- zero	25 gal	GO 90	GOS		
GOS-LUBRICATING OIL, Gear Sub-zero					

- NOTES:**
- FOR OPERATION OF EQUIPMENT IN PROTRACTED COLD TEMPERATURES BELOW -10° F. Remove lubricants prescribed in the key for temperature above -10° F. Relubricate with lubricants specified in the key for temperatures below -10° F.
 - GEAR COUPLING. Repack each time coupling is taken apart.
 - CAPSTAN. Change oil every 2400 hours or every year whichever occurs first.
 - LUBRICANTS. The following is a list of lubricants with the Military Symbols and applicable Specification numbers.

GO	MIL-L-2105	GOS	MIL-L-10324
OE	MIL-L-2104	OES	MIL-L-10295
GAA	MIL-G-10924		

Copy of this Lubrication Order will remain with the equipment at all times; instructions contained herein are mandatory.

BY ORDER OF THE SECRETARY OF THE ARMY:

CREIGHTON W. ABRAMS
General, United States Army
Chief of Staff.

OFFICIAL:

VERNE L. BOWERS
Major General, United States Army
The Adjutant General.

DISTRIBUTION: To be distributed in accordance with DA Form 12-25D (qty req block No. 813) Operator's Maintenance requirements for Marine Equipment: All.

RECOMMENDED CHANGES TO EQUIPMENT TECHNICAL PUBLICATIONS



THEN...JOT DOWN THE
DOPE ABOUT IT ON THIS FORM.
CAREFULLY TEAR IT OUT, FOLD IT
AND DROP IT IN THE MAIL.

SOMETHING WRONG WITH PUBLICATION

FROM: (PRINT YOUR UNIT'S COMPLETE ADDRESS)

DATE SENT

PUBLICATION NUMBER

PUBLICATION DATE

PUBLICATION TITLE

BE EXACT PIN-POINT WHERE IT IS

PAGE
NO.

PARA-
GRAPH

FIGURE
NO.

TABLE
NO.

IN THIS SPACE, TELL WHAT IS WRONG
AND WHAT SHOULD BE DONE ABOUT IT.

PRINTED NAME, GRADE OR TITLE AND TELEPHONE NUMBER

SIGN HERE

PIN: 012009

This fine document...

Was brought to you by me:



[Liberated Manuals -- free army and government manuals](#)

Why do I do it? I am tired of sleazy CD-ROM sellers, who take publicly available information, slap “watermarks” and other junk on it, and sell it. Those masters of search engine manipulation make sure that their sites that sell free information, come up first in search engines. They did not create it... They did not even scan it... Why should they get your money? Why are not letting you give those free manuals to your friends?

I am setting this document FREE. This document was made by the US Government and is NOT protected by Copyright. Feel free to share, republish, sell and so on.

I am not asking you for donations, fees or handouts. If you can, please provide a link to liberatedmanuals.com, so that free manuals come up first in search engines:

<A HREF=<http://www.liberatedmanuals.com/>>Free Military and Government Manuals

- Sincerely
Igor Chudov
<http://igor.chudov.com/>
- [Chicago Machinery Movers](#)