

TUG, HARBOR, DIESEL, 1200 H. P. STEEL, 100 FT DESIGN 3006
(HULL NUMBERS LT 1936 THRU LT 1977 AND LT 2202)

Reference: FEDERAL SUPPLY CATALOG C9100-IL, LO55-1925-204-12-1, 2, 3, 4, 5, 7, 8, TM55-1925-204-12 and TM55-1925-204-34

Intervals are based on normal hours of operations. Adjust to compensate for abnormal operations and severe conditions. During inactive periods, sufficient lubrication must be performed for adequate preservation.

Relubricate after exposure to salt water.

Clean fittings before lubricating.

Clean parts with SOLVENT, Dry-cleaning, Type II, (SD-2). Dry before lubricating.

Lubricate points indicated by dotted arrow shafts on both sides of equipment.

Drain wet crankcases and gear boxes while the lubricant is still warm from previous use. Refill and check level.

FOLD

FOLD

LUBRICANT ● INTERVAL

INTERVAL ● LUBRICANT

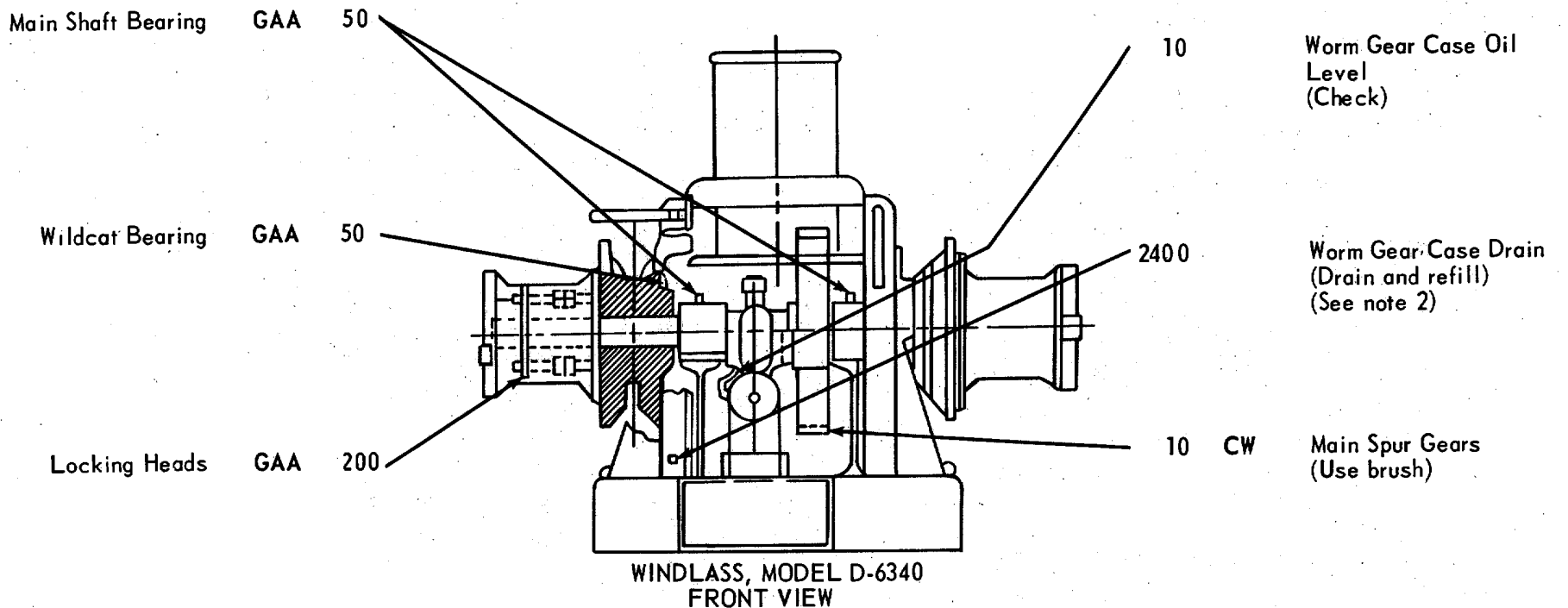

LUBRICANT ● INTERVAL

INTERVAL ● LUBRICANT

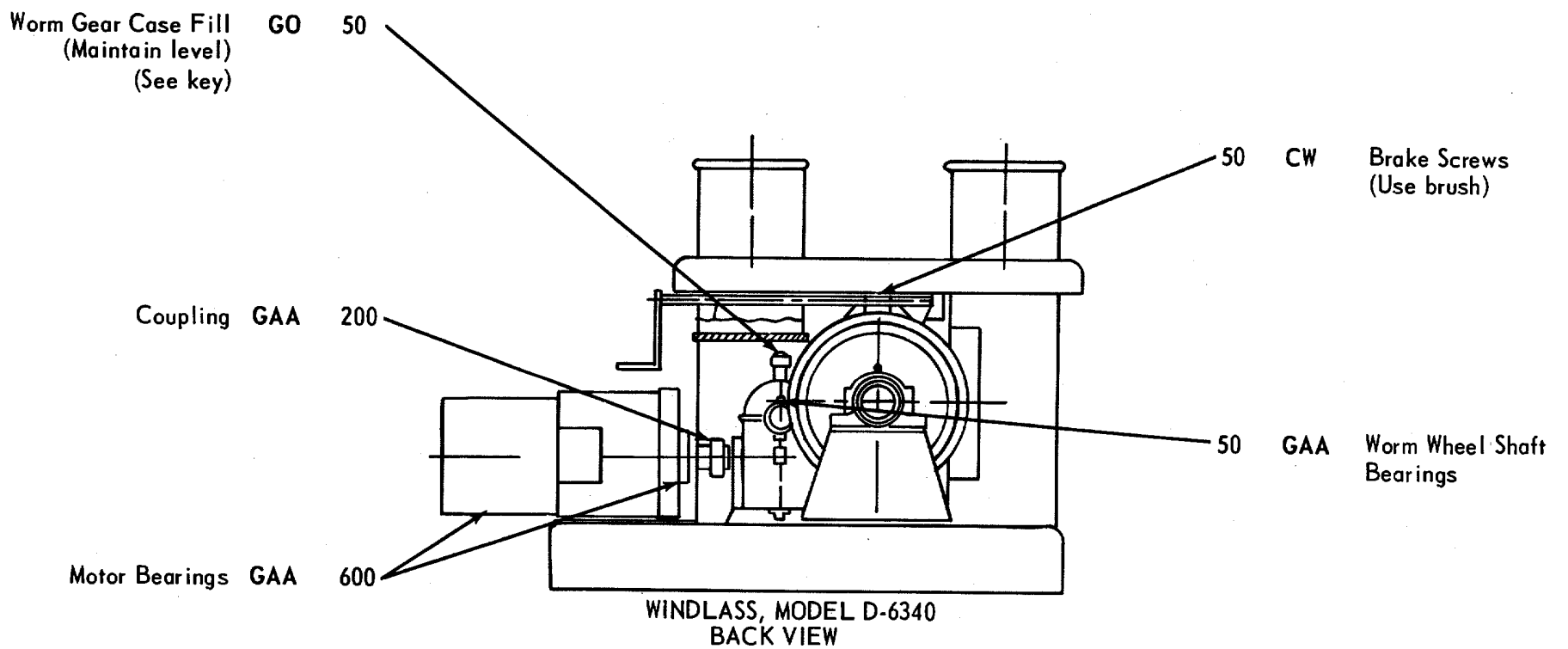

FOLD

FOLD

-KEY-

LUBRICANT	CAPACITY	EXPECTED TEMPERATURES			INTERVALS
		Above +32° F	+ 40° F to -10° F	0° F to -65° F	
GO-LUBRICATING OIL, Gear		.GO 90	GO 80	GOS	Intervals given are in hours of normal operation
Worm Gear Case					
GOS-LUBRICATING OIL, Sub zeros		ALL TEMPERATURES			
GAA-GREASE, Auto & Artillery		CW-II			
CW-LUBRICATING OIL, Exposed Gear					

Notes:

1. FOR OPERATION OF EQUIPMENT IN PROTRACTED COLD TEMPERATURES BELOW -10°F. Remove lubrication prescribed in the key for temperatures above -10°F. Relubricate with lubricants specified in the key for temperatures below -10°F.

2. WORM GEAR. Change oil every 2400 hrs or every year whichever occurs first.

3. LUBRICANTS. The following is a list of lubricants with the Military Symbols and applicable Specification numbers.
 GO MIL-L-2105 GAA MIL-G-10924
 GOSMIL-L-10324 CW VV-L-751

Copy of this Lubrication Order will remain with the equipment at all times; instructions contained herein are mandatory.

BY ORDER OF THE SECRETARY OF THE ARMY:

CREIGHTON W. ABRAMS
 General, United States Army
 Chief of Staff

OFFICIAL:

VERNE L. BOWERS
 Major General United States Army
 The Adjutant General

RECOMMENDED CHANGES TO EQUIPMENT TECHNICAL PUBLICATIONS



*THEN...JOT DOWN THE
DOPE ABOUT IT ON THIS FORM.
CAREFULLY TEAR IT OUT, FOLD IT
AND DROP IT IN THE MAIL.*

SOMETHING WRONG WITH PUBLICATION

FROM: (PRINT YOUR UNIT'S COMPLETE ADDRESS)

DATE SENT

PUBLICATION NUMBER

PUBLICATION DATE

PUBLICATION TITLE

BE EXACT PIN-POINT WHERE IT IS

PAGE
NO.

PARA-
GRAPH

FIGURE
NO.

TABLE
NO.

IN THIS SPACE, TELL WHAT IS WRONG
AND WHAT SHOULD BE DONE ABOUT IT.

PRINTED NAME, GRADE OR TITLE AND TELEPHONE NUMBER

SIGN HERE

This fine document...

Was brought to you by me:



[Liberated Manuals -- free army and government manuals](#)

Why do I do it? I am tired of sleazy CD-ROM sellers, who take publicly available information, slap “watermarks” and other junk on it, and sell it. Those masters of search engine manipulation make sure that their sites that sell free information, come up first in search engines. They did not create it... They did not even scan it... Why should they get your money? Why are not letting you give those free manuals to your friends?

I am setting this document FREE. This document was made by the US Government and is NOT protected by Copyright. Feel free to share, republish, sell and so on.

I am not asking you for donations, fees or handouts. If you can, please provide a link to liberatedmanuals.com, so that free manuals come up first in search engines:

<A HREF=<http://www.liberatedmanuals.com/>>Free Military and Government Manuals

- Sincerely
Igor Chudov
<http://igor.chudov.com/>
- [Chicago Machinery Movers](#)