

ORDER

15 OCTOBER 1973 (Supersedes LO 55-6115-204-12/1, 1 December 1964)

TUG, HARBOR, DIESEL 1200 H. P. STEED 100 FT DESIGN 3006

(HULL NUMBERS LT 1936 THRU LT 1977 AND LT 2202)

Reference: FEDERAL SUPPLY CATALOG C9100-IL, L055-1925-204-12-1, 2, 3, 4, 6, 7, 8, TM55-1925-204-12 and TM55-1925-204-34

Intervals are based on normal hours of operations. Adjust to compensate for abnormal operations and severe conditions. During inactive periods, sufficient lubrication must be performed for adequate preservation.

Clean parts with SOLVENT, Dry-cleaning, Type II, (SD-2). Dry before lubricating.

Lubricate points indicated by dotted arrow shafts on both sides of equipment.

Drain wet crankcases and gear boxes while the lubricant is still warm from previous use. Refill and check level.

Clean fittings before lubricating.

FOLD

FOLD

INTERVAL ● LUBRICANT

LEFT SIDE

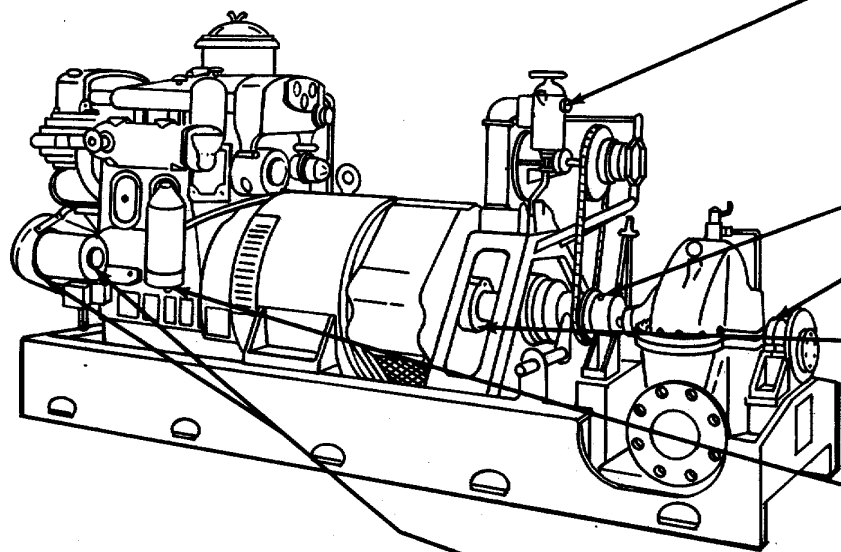

GENERATOR SET WITH FIRE AND SALVAGE PUMP

- 10 Priming Pump Oil Gage (Check level) (See note 3)
- 50 GAA Pump Ball Bearings (Turn cup down one full turn. Refill as necessary)
- 10 OE/HDO Oil Level Sight Gage (See note 2)
- 200 Lube Oil Filter (Clean, replace element)
- 600 OE/HDO Generator (Oil cups)

INTERVAL ● LUBRICANT

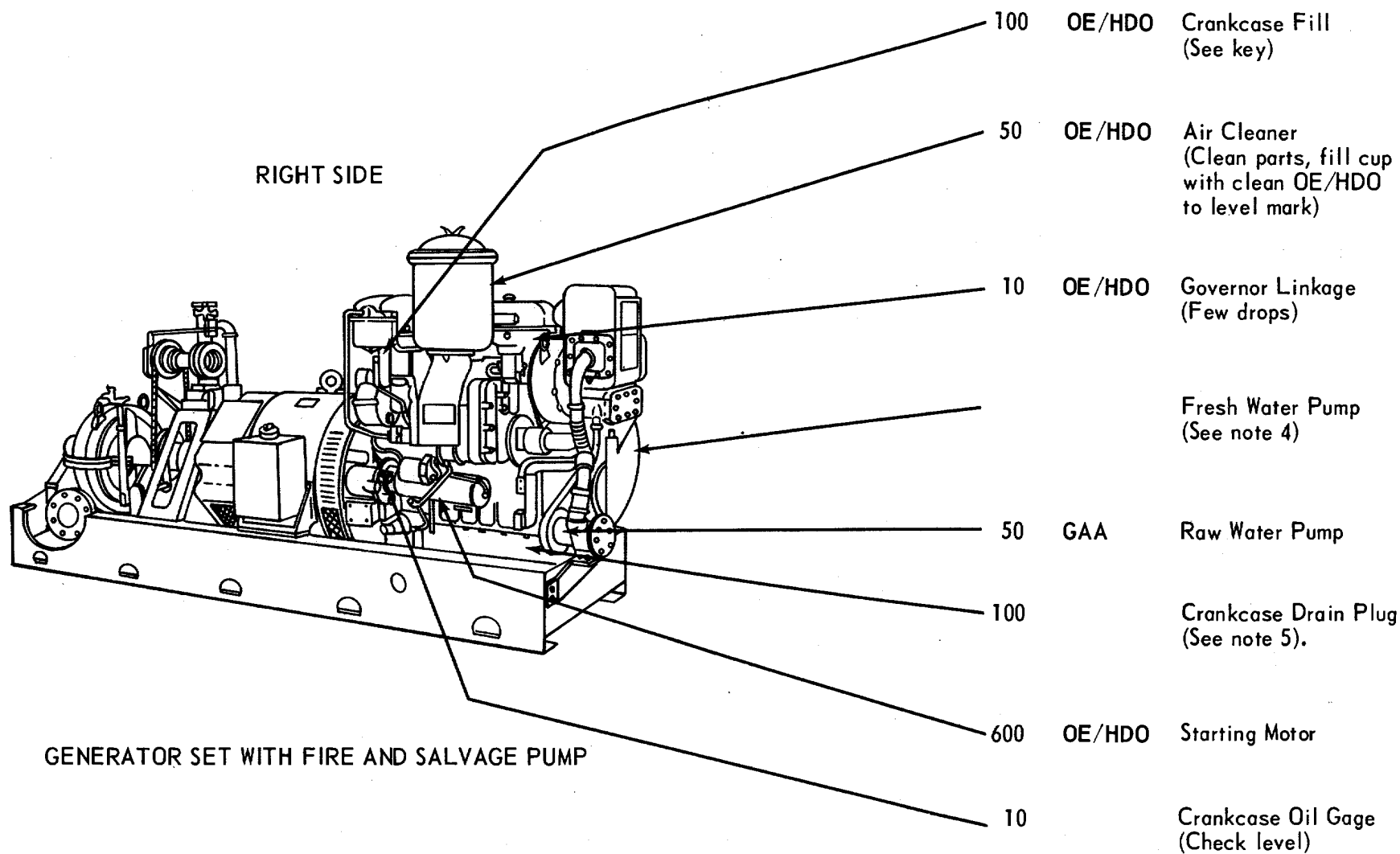

GENERATOR SET WITH FIRE AND SALVAGE PUMP

FOLD

FOLD

-KEY-

LUBRICANTS	CAPACITY	EXPECTED TEMPERATURES			INTERVALS
		Above + 32° F	+ 40° to - 10° F	0° F to - 65° F	
OE/HDO-LUBRICATING OIL, Engine Crankcase Model 3061A Model 4061 A Oil Con Points	15 qts 17 qts	OE/HDO 30	OE/HDO 10	OES	Intervals given are in hours of normal operation
OES-LUBRICATING OIL, Sub-zero GAA-GREASE, Auto & Artillery					
ALL TEMPERATURES					

NOTES:

- FOR OPERATION OF EQUIPMENT IN PROTRACTED COLD TEMPERATURES BELOW - 10° F.** Remove lubricants prescribed in the key for temperatures above -10°F. Relubricate with lubricants specified in the key for temperatures below - 10 ° F.
- OIL LEVEL SIGHT GAGE.** Add oil when necessary.
- PRIMING PUMP.** Check oil level every 10 hours. Remove the filler plug which carries an oil gage in a recess. Place the oil gage in the oil fill plug hole and check oil level. Keep oil at high level mark, use OE/HDO 10, replace plug.
- FRESH WATER PUMP.** Bearings are permanently sealed and lubricated for the life of the bearing.
- CRANKCASE DRAIN.** Remove plug and drain. Replace plug and refill crankcase with proper grade OE/HDO to full mark on oil gage.

- LUBRICANTS:** The following is a list of lubricants with the Military Symbols and the applicable specification numbers.
OE/HDO MIL-L-2104C OES MIL-L-10295
GAA MIL-G-10 924

Copy of this Lubrication Order will remain with the equipment at all times; instructions contained herein are mandatory.

BY ORDER OF THE SECRETARY OF THE ARMY
CREIGHTON W. ABRAMS
General, United States Army
Chief of Staff

OFFICIAL:

VERNE L. BOWERS
Major General, United States Army
The Adjutant General

DISTRIBUTION: To be distributed in accordance with DA Form 12-25D (qty rqr block No. 813) Operator's Maintenance requirements for Marine Equipment: All.

RECOMMENDED CHANGES TO EQUIPMENT TECHNICAL PUBLICATIONS



THEN...JOT DOWN THE
DOPE ABOUT IT ON THIS FORM.
CAREFULLY TEAR IT OUT, FOLD IT
AND DROP IT IN THE MAIL.

SOMETHING WRONG WITH PUBLICATION

FROM: (PRINT YOUR UNIT'S COMPLETE ADDRESS)

DATE SENT

PUBLICATION NUMBER

PUBLICATION DATE

PUBLICATION TITLE

BE EXACT PIN-POINT WHERE IT IS

PAGE NO.	PARA-GRAPH	FIGURE NO.	TABLE NO.
----------	------------	------------	-----------

IN THIS SPACE, TELL WHAT IS WRONG
AND WHAT SHOULD BE DONE ABOUT IT.

TEAR ALONG PERFORATED LINE

PRINTED NAME, GRADE OR TITLE AND TELEPHONE NUMBER

SIGN HERE

PIN# 012007

This fine document...

Was brought to you by me:



[Liberated Manuals -- free army and government manuals](#)

Why do I do it? I am tired of sleazy CD-ROM sellers, who take publicly available information, slap “watermarks” and other junk on it, and sell it. Those masters of search engine manipulation make sure that their sites that sell free information, come up first in search engines. They did not create it... They did not even scan it... Why should they get your money? Why are not letting you give those free manuals to your friends?

I am setting this document FREE. This document was made by the US Government and is NOT protected by Copyright. Feel free to share, republish, sell and so on.

I am not asking you for donations, fees or handouts. If you can, please provide a link to liberatedmanuals.com, so that free manuals come up first in search engines:

<A HREF=<http://www.liberatedmanuals.com/>>Free Military and Government Manuals

- Sincerely
Igor Chudov
<http://igor.chudov.com/>
- [Chicago Machinery Movers](#)