

TUG, HARBOR DIESEL, 1200 H. P. STEEL 100 FT DESIGN 3006

(HULL NUMBERS LT 1936 THRU LT 1977 AND LT 2202)

Reference: FEDERAL SUPPLY CATALOG C9100-IL, LO55-1925-204-12-1, 2, 3, 5, 6, 7, 8, TM55-1925-204-12 and TM55-1925-204-34

Intervals are based on normal hours of operations, Adjust to compensate for abnormal operations and severe conditions. During inactive periods, sufficient lubrication must be performed for adequate preservation.

Clean parts with SOLVENT, Dry-cleaning, Type 11, (SD-2). Dry before lubricating.

Relubricate after exposure to salt water.

Lubricate points indicated by dotted arrow shafts on both sides of equipment.

Clean fittings before lubricating.

Drain crankcases and gear boxes while the lubricant is still warm from previous use. Refill and check level.

FOLD

FOLD

LUBRICANT ● INTERVAL

INTERVAL ● LUBRICANT

Worm Gear Case Fill and Level Plug (Check, maintain level at fill plug) (See key)

GO

50

50

GAA

Main Shaft Bearings

Worm Gear Case Drain (Drain and refill) (See note 4)

2400

50

CW

Main Spur Gears (Apply with brush)

Motor Bearings GAA

200

50

GAA

Pinion Shaft Bearing

MODEL R-6293 CAPSTAN

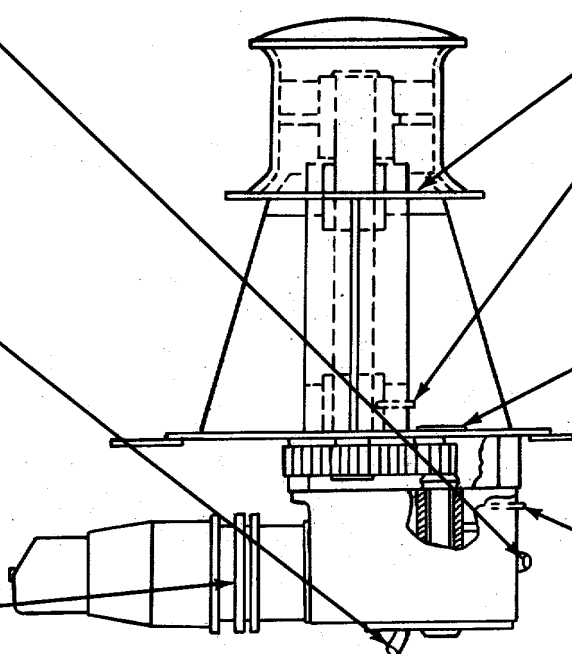

Air Cleaner
(Dry type no lubrication
required)

Crankcase Fill and OE/HDO 10
Level Cap
(Check level)(See key)

Crankcase Drain 500
(Drain and refill)
(See note 5)

Bearings, Motor GAA 600

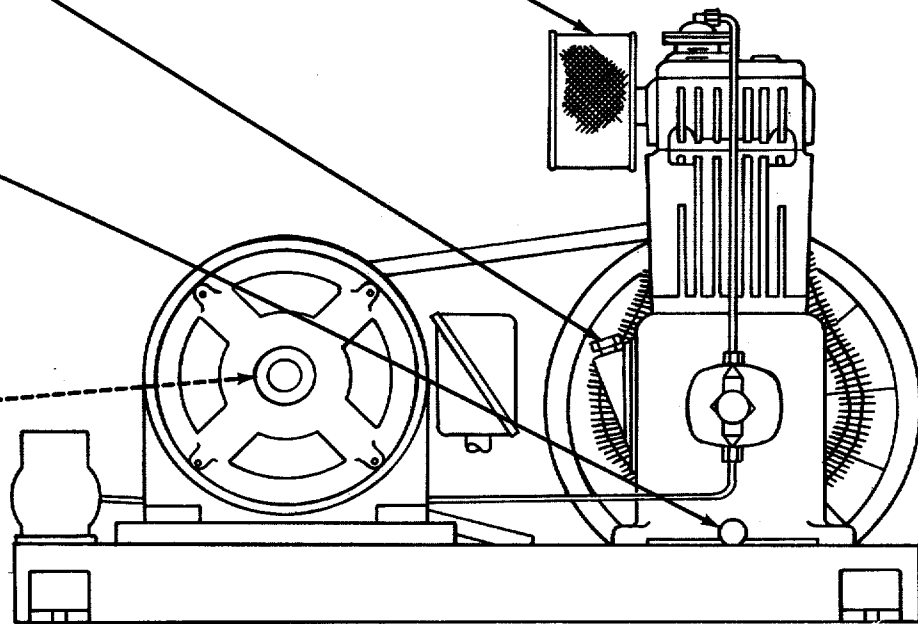

MODEL D340 AIR COMPRESSOR

MODEL D340 AIR COMPRESSOR

FOLD

FOLD

-KEY-

LUBRICANTS	CAPCAITY	EXPECTED TEMPERATURES			INTERVALS
		Above + 32° F	+ 40° F to - 10° F	0° F to - 65° F	
OE/HDO-LUBRICATING OIL, Engine Compressor Crankcase	6 qts	OE/HDO 30	OE/HDO 10	OES	Intervals given are in hours of normal operation
OES-LUBRICATING OIL, Sub-zero					
GO-LUBRICATING OIL, Gear of Capstan Worm Gear Case	10 gal	GO 90	GO 80	GOS	
GOS-LUBRICATING OIL, Gear Sub-zero					
CW-LUBRICATING OIL, Exposed gear			CW-II ALL TEMPERATURES		
GAA-GREASE, Auto & Artillery					

NOTES:

1. FOR OPERATION OF EQUIPMENT: IN PROTRACTED COLD TEMPERATURES BELOW -10° F. Remove lubricants prescribed in the key for temperatures above -10°F. Relubricate with lubricant specified in the key for temperatures below -10°F.

2. OIL CAN POINTS. Every 50 hours clean and lightly coat control linkages, hinges, and all exposed adjusting threads with OE/HDO.

3. LUBRICANTS: The following is a list of lubricants with the Military Symbols and the applicable specification numbers.

OE MIL-L-2104C	OES MIL-L-10295
GO MI L-L-2105	GAA MIL-G-10924
GOS MI L-L-10324	CW VV-L-751

4. WORM GEAR. Change oil every 2400 hrs or every year whichever occurs first.

5. COMPRESSOR. Change oil every 500 hours or every 90 days whichever occurs first.

Copy of this Lubrication Order will remain with the equipment at all times; instructions contained herein are mandatory.

BY ORDER OF THE SECRETARY OF THE ARMY
CREIGHTON W. ABRAMS
General, United States Army
Chief of Staff.

OFFICIAL:

VERNE L. BOWERS
Major General, United States Army,
The Adjutant General

DISTRIBUTION: To be distributed in accordance with DA Form 12-25D (qty rqr block No. 813) Operator's Maintenance requirements for Marine Equipment: All.

RECOMMENDED CHANGES TO EQUIPMENT TECHNICAL PUBLICATIONS



THEN...JOT DOWN THE
DOPE ABOUT IT ON THIS FORM.
CAREFULLY TEAR IT OUT, FOLD IT
AND DROP IT IN THE MAIL.

SOMETHING WRONG WITH PUBLICATION

FROM: (PRINT YOUR UNIT'S COMPLETE ADDRESS)

DATE SENT

PUBLICATION NUMBER

PUBLICATION DATE

PUBLICATION TITLE

BE EXACT PIN-POINT WHERE IT IS

PAGE NO.	PARA-GRAPH	FIGURE NO.	TABLE NO.

IN THIS SPACE, TELL WHAT IS WRONG
AND WHAT SHOULD BE DONE ABOUT IT.

TEAR ALONG PERFORATED LINE

PRINTED NAME, GRADE OR TITLE AND TELEPHONE NUMBER

SIGN HERE

PIN# 012006

This fine document...

Was brought to you by me:



[Liberated Manuals -- free army and government manuals](#)

Why do I do it? I am tired of sleazy CD-ROM sellers, who take publicly available information, slap “watermarks” and other junk on it, and sell it. Those masters of search engine manipulation make sure that their sites that sell free information, come up first in search engines. They did not create it... They did not even scan it... Why should they get your money? Why are not letting you give those free manuals to your friends?

I am setting this document FREE. This document was made by the US Government and is NOT protected by Copyright. Feel free to share, republish, sell and so on.

I am not asking you for donations, fees or handouts. If you can, please provide a link to liberatedmanuals.com, so that free manuals come up first in search engines:

<A HREF=<http://www.liberatedmanuals.com/>>Free Military and Government Manuals

- Sincerely
Igor Chudov
<http://igor.chudov.com/>
- [Chicago Machinery Movers](#)