

TUG, HARBOR, DIESEL, 1200 H. P. STEEL, 1 - FT DESIGN 3006
(HULL NUMBERS LT 1936 THRU LT 1977 AND LT 2202)

Reference FEDERAL SUPPLY CATALOG C9100-IL, LO55-1925-204-12-1, 2, 4, 5, 6, 7, 8, TM55-1925-204-12 and TM55-1925-204-34

Intervals are based on normal hours of operations. Adjust to compensate for abnormal operations and severe conditions. During inactive periods, sufficient lubrication must be performed for adequate preservation. Clean fittings before lubricating.

Clean parts with SOLVENT, Dry-cleaning, Type II, (SD-2). Dry before lubricating.

Lubricate points indicated by dotted arrow shafts on both sides of equipment.

Drain wet crankcases, gear boxes and hydraulic reservoirs while the lubricant is still warm from previous use. Refill and check level.

FOLD

FOLD

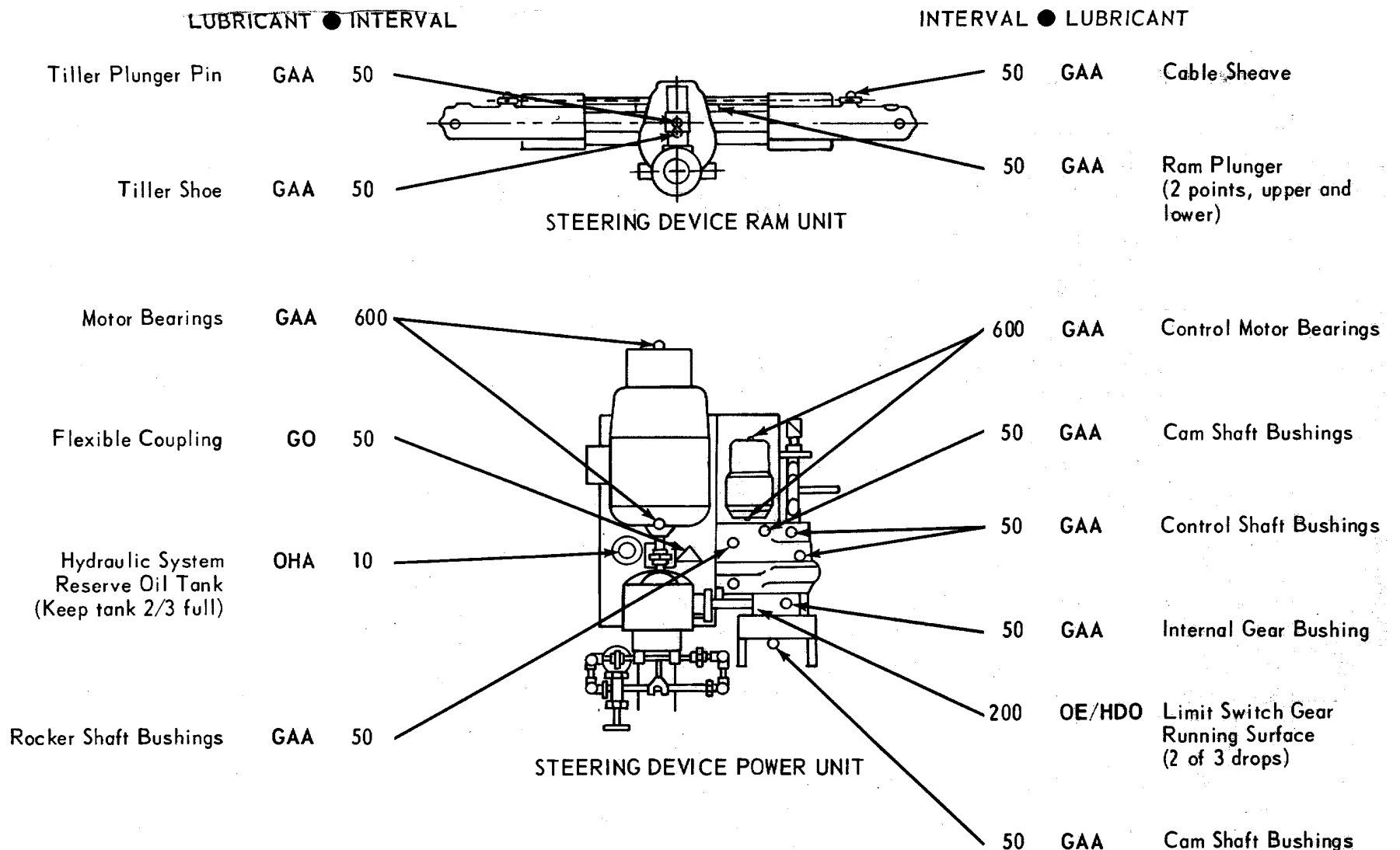

LUBRICANT ● INTERVAL

INTERVAL ● LUBRICANT

Hand Hydraulic Steering Vertical Shaft Upper Bushing

GAA 50

Hand Hydraulic Steering Vertical Shaft Lower Bushing

GAA 50

Hand Hydraulic Pump Pinion Drive Bushing

GAA 50

Hand Hydraulic Pump Pinion Drive Bushing

GAA 50

Hand Hydraulic Steering Horizontal Shaft Bushing

GAA 50

Miter Gear Shaft Bearings
(2 points on each of 3 miter gear boxes)

GAA 50

STEERING DEVICE CONSOLE

10 OE/HDO Dial Indicators (Oil can points)

10 OHA Hydraulic System Reserve Oil Tank (Keep tank 2/3 full)

50 GAA Electrohydraulic Steering Shaft Upper Bushing

50 GAA Electrohydraulic Steering Shaft Lower Bushing

50 GAA Miter Gear Box (3 boxes) (Apply grease to gears)

FOLD

FOLD

-KEY-

LUBRICANT	CAPACITY	EXPECTED TEMPERATURES			INTERVALS
		Above +32° F	+ 40° F to -10° F	0° F to -65° F	
OE /HDO-LUBRICATING OIL, Engine		OE/HDO 30:	OEHDO 10	OES	Intervals given are in hours of normal operation
Oil Can Points					
OES-LUBRICATING OIL, Sub zeros		GO 90	GO 80	GOS	
GO-LUBRICATING OIL, Gear					
OHA-HYDRAULIC FLUID		ALL TEMPERATURES			
GAA-GREASE, Auto & Artillery					

Notes:

1. FOR OPERATION OF EQUIPMENT IN PROTRACTED COLD TEMPERATURES BELOW -10°F. Remove lubrication prescribed in the key for temperatures above -10°F. Relubricate with lubricants specified in the key for temperatures below - 10° F.

Copy of this Lubrication Order will remain with the equipment at all times; instructions contained herein are mandatory.

BY ORDER OF THE SECRETARY OF THE ARMY:

CREIGHTON W. ABRAMS
General, United States Army
Chief of Staff

OFFICIAL:

VERNE L. BOWERS
Major General United States Army
The Adjutant General

2. LUBRICANTS. The following is a list of lubricants with the Military Symbols and applicable Specification numbers.
OE/HDO MIL-L-2104C OES MIL-L-10295
GAA MIL-G-10924 GOS MIL-L-10324
GO MIL-L-2105 OHA MIL-H-5606

DISTRIBUTION: To be distributed in accordance with DA Form 12-25D (qty req block No. 813) Operator's Maintenance requirements for Marine Equipment: All

RECOMMENDED CHANGES TO EQUIPMENT TECHNICAL PUBLICATIONS



THEN...JOT DOWN THE DOPE ABOUT IT ON THIS FORM. CAREFULLY TEAR IT OUT, FOLD IT AND DROP IT IN THE MAIL.

SOMETHING WRONG WITH PUBLICATION

FROM: (PRINT YOUR UNIT'S COMPLETE ADDRESS)

DATE SENT

PUBLICATION NUMBER

PUBLICATION DATE

PUBLICATION TITLE

BE EXACT PIN-POINT WHERE IT IS

PAGE NO.

PARA-GRAPH

FIGURE NO.

TABLE NO.

IN THIS SPACE, TELL WHAT IS WRONG AND WHAT SHOULD BE DONE ABOUT IT.

TEAR ALONG PERFORATED LINE

PRINTED NAME, GRADE OR TITLE AND TELEPHONE NUMBER

SIGN HERE

This fine document...

Was brought to you by me:



[Liberated Manuals -- free army and government manuals](#)

Why do I do it? I am tired of sleazy CD-ROM sellers, who take publicly available information, slap “watermarks” and other junk on it, and sell it. Those masters of search engine manipulation make sure that their sites that sell free information, come up first in search engines. They did not create it... They did not even scan it... Why should they get your money? Why are not letting you give those free manuals to your friends?

I am setting this document FREE. This document was made by the US Government and is NOT protected by Copyright. Feel free to share, republish, sell and so on.

I am not asking you for donations, fees or handouts. If you can, please provide a link to liberatedmanuals.com, so that free manuals come up first in search engines:

<A HREF=<http://www.liberatedmanuals.com/>>Free Military and Government Manuals

- Sincerely
Igor Chudov
<http://igor.chudov.com/>
- [Chicago Machinery Movers](#)