

LUBRICATION ORDER
10 NOVEMBER 1980 (Supersedes LO55-1905-217-12-1, 18 October 1968)

LANDING CRAFT, MECHANIZED; STEEL; DIESEL POWER DRIVEN,

74 FT. LG. HULL NOS. LCM-8500 THRU LCM-8519

Reference: TM55-1905-217-12. LO55-1905-217-12-2 and -3. C9100-IL

Intervals are based on normal hours of operation. Adjust to compensate for abnormal operation and severe conditions. During inactive periods sufficient lubrication must be performed for adequate preservation.

Lubricate points indicated by dotted arrow shafts on both sides of landing craft. Clean fittings before lubricating
KEY

LUBRICANTS	CAPACITY	EXPECTED TEMPERATURES			INTERVALS
		Above +32 °F	+40°F to -10°F	0 °F to -65 °F	
GO-LUBRICATING OIL. Gear, Multi-purpose	7-1/2 QTS	GO 90	GO 90	GOS	Intervals are based in hours of normal operation.
GOS-LUBRICATING OIL. Gear, Sub zero		(MIL-L-2105)	(MIL-L-2105)	(MIL-L-10324)	
GAA-GREASE. Automotive and Artillery		ALL TEMPERATURES (MIL-L-10924)			
HYDRAULIC FLUID					
Steering System	23 gals	2135-TH	2135-TH	2075-TH	
Ramp Hoist System	100 gals	(MIL-L-17672)	(MIL-L-10672)	(MIL-L-10672)	
Starting System	7 gals				

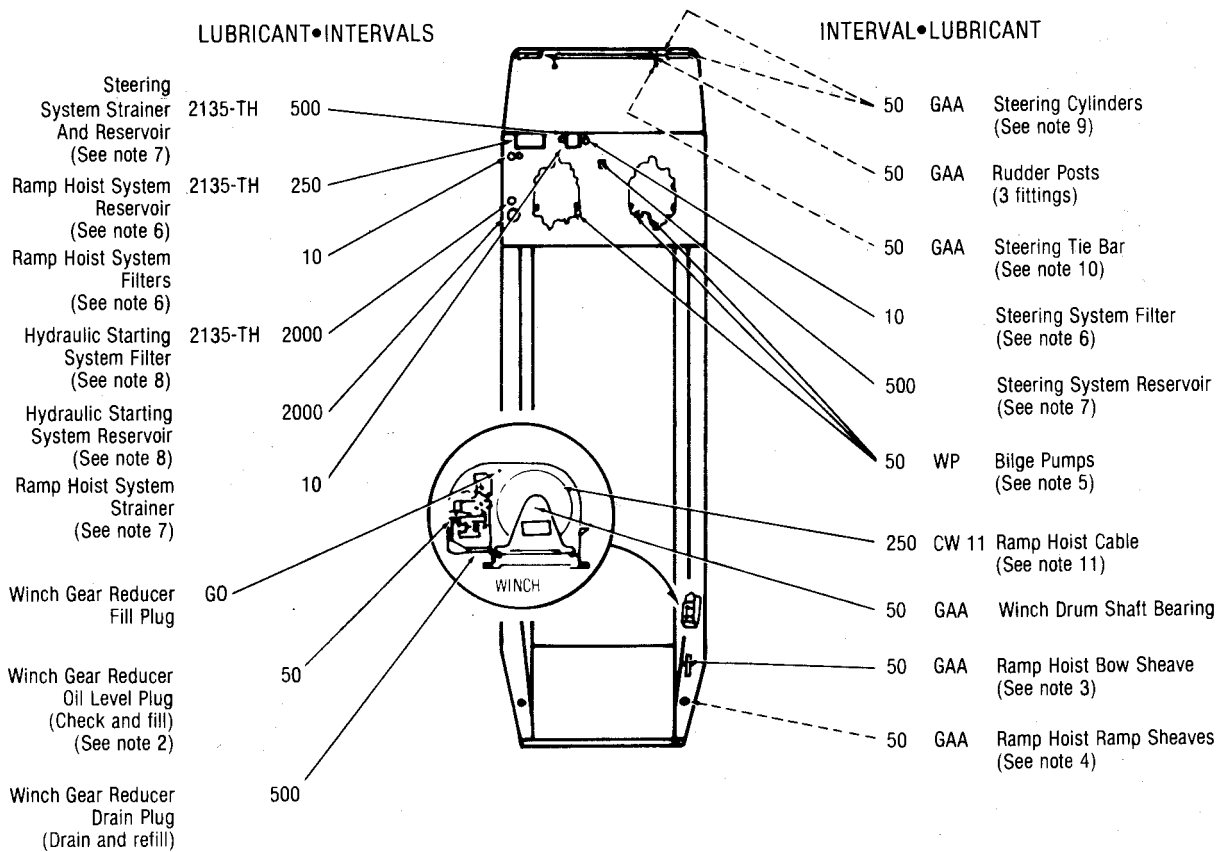

NOTES:

1. FOR OPERATION OF EQUIPMENT IN PROTRACTED COLD TEMPERATURES BELOW 10°F. Remove lubricants prescribed in the key for temperatures above 10° F. Lubricate with lubricants specified in the key for temperatures below 10°F.
2. WINCH. Remove inspection plate and remove oil level plug to check oil level. Add lubricant as required to bring up to level plug. Replace oil level plug and inspection cover. Change oil every 1000 hours.
3. BOW SHEAVE. Lubricate at fitting on deck.
4. RAMP SHEAVES. Lubricate through holes on side of ramp. One fitting each sheave.
5. BILGE PUMPS. Turn down grease cup one full turn to replenish grease cup every 50 hours. Hull No. 8520 thru 8539 only. WRT - grease, aircraft general purpose.
6. STEERING SYSTEM AND RAMP HOIST SYSTEM FILTERS. Change filters every 250 hours.
7. STEERING SYSTEM AND RAMP HOIST SYSTEM SCREENS. Drain fluid from reservoir. Remove reservoir top cover and remove screen. Clean screen in solvent and reinstall. Fill system with fluid at reservoir filler and vent cap.
8. STARTING SYSTEM FILTER. Drain reservoir, service filter and refill reservoir as specified in TM 55-1905-217-12.

DISTRIBUTION: To be distributed in accordance with DA Form 12-25D, Operator maintenance requirements for Marine Equipment, All.

9. STEERING CYLINDER. Remove pin and lubricating pin sparingly and replace pin.
10. STEERING TIE BAR. Remove pin and lubricate pin sparingly and replace pin.
11. RAMP HOIST CABLE. Clean and lubricate with CW every 250 hours. CW-lubricating oil, exposed gear.
12. RAMP LOCKING CYLINDERS. Grease every 50 hours with GAA
13. REVERSING MECHANISM LEVER ARM. Grease every 50 hours with GAA.

You can improve this publication by calling attention to errors and by recommending improvements and by stating your reasons for the recommendations. Your letter or DA2028, Recommended Changes to Publications and Forms, should be mailed directly to U.S. Army Troop Support and Aviation Materiel Readiness Command, Attn: DRSTS-MTPS, 4300 Goodfellow Blvd., St. Louis, Mo., 63120.

Copy of this Lubrication Order will remain with the equipment at all times; instructions contained herein are mandatory.

By Order of the Secretary of the Army

Official:

E. C. MEYER
General, United States Army
Chief of Staff

J. C. PENNINGTON
Major General, United States Army
The Adjutant General

*U.S. GOVERNMENT PRINTING OFFICE : 1992 - 311-826 (60004)

RECOMMENDED CHANGES TO EQUIPMENT TECHNICAL PUBLICATIONS

 <div style="border: 1px solid black; border-radius: 15px; padding: 5px; margin: 10px auto; width: 80%; text-align: center;"> <p><i>THEN...JOT DOWN THE DOPE ABOUT IT ON THIS FORM. CAREFULLY TEAR IT OUT, FOLD IT AND DROP IT IN THE MAIL.</i></p> </div>		SOMETHING WRONG WITH PUBLICATION		
		FROM: (PRINT YOUR UNIT'S COMPLETE ADDRESS)		
PUBLICATION NUMBER		DATE SENT		
PUBLICATION DATE		PUBLICATION TITLE		
BE EXACT PIN-POINT WHERE IT IS				
PAGE NO.	PARA-GRAPH	FIGURE NO.	TABLE NO.	<p style="text-align: center; font-weight: bold;">IN THIS SPACE, TELL WHAT IS WRONG AND WHAT SHOULD BE DONE ABOUT IT.</p>
PRINTED NAME, GRADE OR TITLE AND TELEPHONE NUMBER			SIGN HERE	

The Metric System and Equivalents

Linear Measure

1 centimeter = 10 millimeters = .39 inch
 1 decimeter = 10 centimeters = 3.94 inches
 1 meter = 10 decimeters = 39.37 inches
 1 dekameter = 10 meters = 32.8 feet
 1 hectometer = 10 dekameters = 328.08 feet
 1 kilometer = 10 hectometers = 3,280.8 feet

Weights

1 centigram = 10 milligrams = .15 grain
 1 decigram = 10 centigrams = 1.54 grains
 1 gram = 10 decigrams = .035 ounce
 1 decagram = 10 grams = .35 ounce
 1 hectogram = 10 decagrams = 3.52 ounces
 1 kilogram = 10 hectograms = 2.2 pounds
 1 quintal = 100 kilograms = 220.46 pounds
 1 metric ton = 10 quintals = 1.1 short tons

Liquid Measure

1 centiliter = 10 milliliters = .34 fl. ounce
 1 deciliter = 10 centiliters = 3.38 fl. ounces
 1 liter = 10 deciliters = 33.81 fl. ounces
 1 dekaliter = 10 liters = 2.64 gallons
 1 hectoliter = 10 dekaliters = 26.42 gallons
 1 kiloliter = 10 hectoliters = 264.18 gallons

Square Measure

1 sq. centimeter = 100 sq. millimeters = .155 sq. inch
 1 sq. decimeter = 100 sq. centimeters = 15.5 sq. inches
 1 sq. meter (centare) = 100 sq. decimeters = 10.76 sq. feet
 1 sq. dekameter (are) = 100 sq. meters = 1,076.4 sq. feet
 1 sq. hectometer (hectare) = 100 sq. dekameters = 2.47 acres
 1 sq. kilometer = 100 sq. hectometers = .386 sq. mile

Cubic Measure

1 cu. centimeter = 1000 cu. millimeters = .06 cu. inch
 1 cu. decimeter = 1000 cu. centimeters = 61.02 cu. inches
 1 cu. meter = 1000 cu. decimeters = 35.31 cu. feet

Approximate Conversion Factors

<i>To change</i>	<i>To</i>	<i>Multiply by</i>	<i>To change</i>	<i>To</i>	<i>Multiply by</i>
inches	centimeters	2.540	ounce-inches	Newton-meters	.007062
feet	meters	.305	centimeters	inches	.394
yards	meters	.914	meters	feet	3.280
miles	kilometers	1.609	meters	yards	1.094
square inches	square centimeters	6.451	kilometers	miles	.621
square feet	square meters	.093	square centimeters	square inches	.155
square yards	square meters	.836	square meters	square feet	10.764
square miles	square kilometers	2.590	square meters	square yards	1.196
acres	square hectometers	.405	square kilometers	square miles	.386
cubic feet	cubic meters	.028	square hectometers	acres	2.471
cubic yards	cubic meters	.765	cubic meters	cubic feet	35.315
fluid ounces	milliliters	29.573	cubic meters	cubic yards	1.308
pints	liters	.473	milliliters	fluid ounces	.034
quarts	liters	.946	liters	pints	2.113
gallons	liters	3.785	liters	quarts	1.057
ounces	grams	28.349	liters	gallons	.264
pounds	kilograms	.454	grams	ounces	.035
short tons	metric tons	.907	kilograms	pounds	2.205
pound-feet	Newton-meters	1.356	metric tons	short tons	1.102
pound-inches	Newton-meters	.11296			

Temperature (Exact)

°F	Fahrenheit temperature	5/9 (after subtracting 32)	Celsius temperature	°C
----	---------------------------	-------------------------------	------------------------	----

PIN: 012140-000

This fine document...

Was brought to you by me:



[Liberated Manuals -- free army and government manuals](#)

Why do I do it? I am tired of sleazy CD-ROM sellers, who take publicly available information, slap “watermarks” and other junk on it, and sell it. Those masters of search engine manipulation make sure that their sites that sell free information, come up first in search engines. They did not create it... They did not even scan it... Why should they get your money? Why are not letting you give those free manuals to your friends?

I am setting this document FREE. This document was made by the US Government and is NOT protected by Copyright. Feel free to share, republish, sell and so on.

I am not asking you for donations, fees or handouts. If you can, please provide a link to liberatedmanuals.com, so that free manuals come up first in search engines:

<A HREF=<http://www.liberatedmanuals.com/>>Free Military and Government Manuals

- Sincerely
Igor Chudov
<http://igor.chudov.com/>
- [Chicago Machinery Movers](#)