

LO 5-4610-218-12

28 OCTOBER 1988

[Supersedes LO5-4610-218-12, 17 August 1987]

WATER PURIFICATION UNIT, VAN TYPE BODY MOUNTED
 ELECTRIC DRIVEN, AC, 115, 208V, SINGLE AND 3
 PHASE, 60 CYCLE 1/20 TO 2 HP, 1500 GPH
 (EMC MODEL EMC-1500S)

Reference TM 5-4610-218-12 (9100 IL)

Approved for public release; distribution is unlimited

Intervals and related task-hour times are based on normal hours of operation. The task-hour time specified is the time you need to do all the services prescribed for a particular interval. Change the interval if your lubricants are contaminated or if you are operating the equipment under adverse operating conditions, including longer than usual operating hours. You may extend the interval during periods of low activity, but you must take adequate preservation precautions.

*The time specified is the time required to perform all services at the particular interval.

Clean fittings before lubricating. Lubricate points indicated by dotted arrow

shaft on both sides of equipment. Clean parts with drycleaning SOLVENT (SD), type II or equivalent. Dry before lubricating. Drain gear case when HOT. Fill and check level. The lowest level of maintenance authorized to lubricate a point is indicated by one of the following: (C) Operator/Crew, or (O) Organizational Maintenance.

You can help improve this manual. If you find any mistakes or if you know of a way to improve the procedures, please let us know. Mail your letter or DA Form 2028 (Recommended Changes to Publications and Blank Forms) direct to: Commander, US Army Troop Support Command, ATTN: AMSTR-MCTS 4300 Goodfellow Blvd. St. Louis, MO 63120-1798. A reply will be furnished to you.

TOTAL TASK HOURS (Card 1)		TOTAL TASK HOURS (Card 2)	
INTERVAL	TASK HOURS	INTERVAL	TASK HOURS
W	0.1	W	0.5
M	0.2	M	0.1
A	0.3	A	0.5

LUBRICANT • INTERVAL

INTERVAL • LUBRICANT

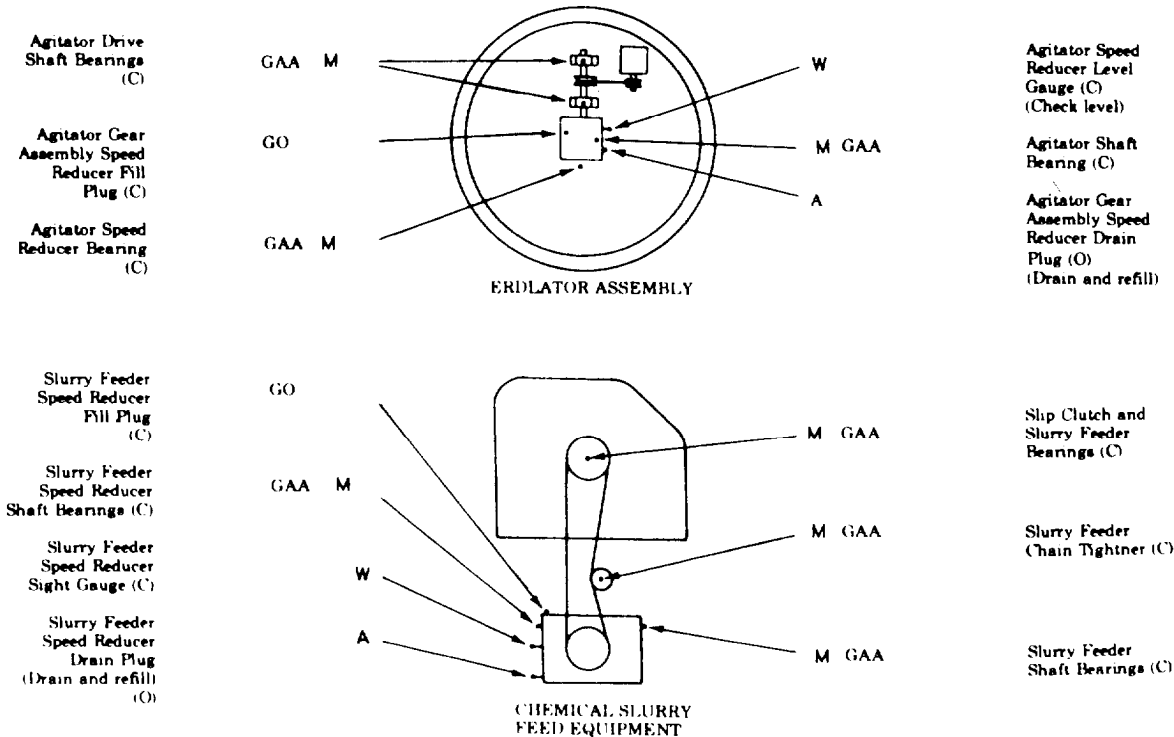

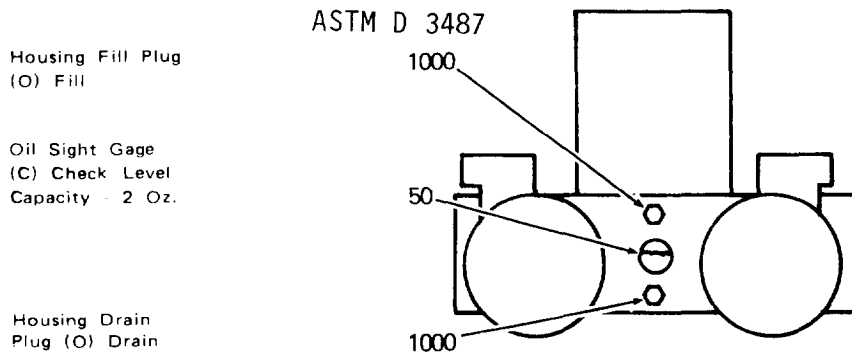
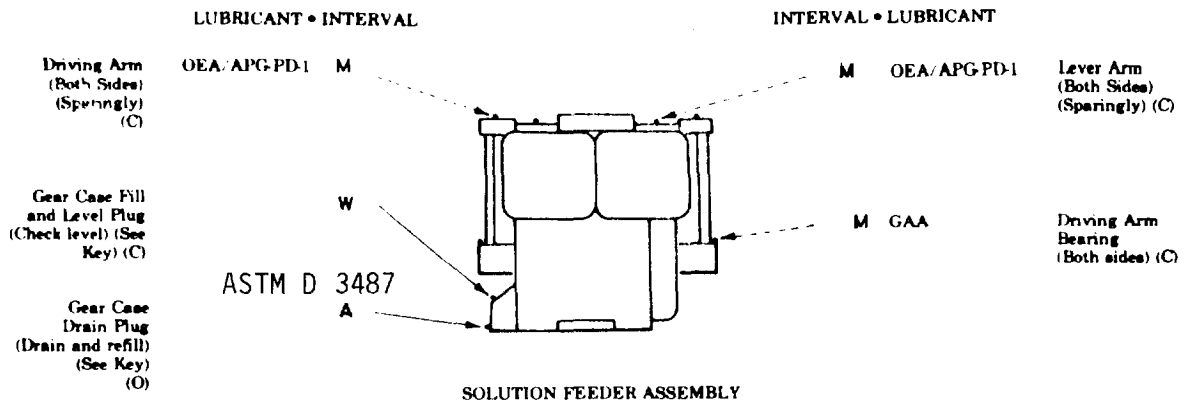

KEY

LUBRICANTS	REFILL CAPACITY (ADD)	EXPECTED TEMPERATURES			INTERVALS
		ABOVE +32°F	0°F to -65°F	+40°F to 10°F	
ASTM D 3487 Insulating Oil, Electrical Solution Feeder gear case (VV-1 538)	5qt (4.76L)	ASTM D 3487	ASTM D 3487	ASTM D 3487	W=50 hours or weekly M=100 hours or monthly A=1000 hours or annually
OEA/APG-PD-1 Lubricating Oil, Engine, subzero	(MIL-L-46167)	OEA/PAG-PD-1	OEA/PAG-PD-1	OEA/PAG-PD-1	
GO Lubricating Oil Gear (MIL L 2105)		GO 140	GO 5	GO 90	
Agitator Speed Reducer					
Slurry Feed Speed Reducer	9/16 qt (.53 liter)				
GO8 Lubricating Oil Gear Subzero (MIL L 10324)	3/4 qt (.70 liter)	ALL TEMPERATURES			
GAA Grease, Automotive and Artillery (MIL-G-10924)		ALL TEMPERATURES			For arctic operation, refer to TM 9-207

NOTES:

1. FOR OPERATION OF EQUIPMENT IN PROTRACTED COLD TEMPERATURES BELOW -10°F (-23°C). Remove lubricants prescribed in the key for temperatures above -10°F (-23°C). Clean parts with SOLVENT, dry-cleaning. Relubricant with lubricants specified in the key for temperatures below -10°F (-23°C).

2. OIL CAN POINTS. Every 50 hours clean and lightly coat all door hinges, latches and cables with OEA/APG-PD-1.

Copy of this Lubrication Order will remain with the equipment at all times; instructions contained herein are mandatory.

BY ORDER OF THE SECRETARY OF THE ARMY:

CARL E. VUONO
General, United States Army
Chief of Staff

OFFICIAL:

WILLIAM J. MEEHAN, II
Brigadier General, United States Army
The Adjutant General

DISTRIBUTION: To be distributed in accordance with DA Form 12-25A, Operator and Unit Maintenance requirements for Water Purification Unit, Electric, Van Type, Body Mounted, 115/208V, 60HZ, 1&3 PH, 1/20-2 HP, 1500 GPM (EMC-1500S).

PIN: 037657-000

This fine document...

Was brought to you by me:



[Liberated Manuals -- free army and government manuals](#)

Why do I do it? I am tired of sleazy CD-ROM sellers, who take publicly available information, slap “watermarks” and other junk on it, and sell it. Those masters of search engine manipulation make sure that their sites that sell free information, come up first in search engines. They did not create it... They did not even scan it... Why should they get your money? Why are not letting you give those free manuals to your friends?

I am setting this document FREE. This document was made by the US Government and is NOT protected by Copyright. Feel free to share, republish, sell and so on.

I am not asking you for donations, fees or handouts. If you can, please provide a link to liberatedmanuals.com, so that free manuals come up first in search engines:

<A HREF=<http://www.liberatedmanuals.com/>>Free Military and Government Manuals

- Sincerely
Igor Chudov
<http://igor.chudov.com/>
- [Chicago Machinery Movers](#)