

**PUMPING ASSEMBLY, FLAMMABLE LIQUID, BULK  
TRANSFER, GASOLINE ENGINE DRIVEN, 350 GPM  
CAPACITY, 275 FEET TOTAL HEAD, WHEEL  
MOUNTED (PEABODY BARNES INC., MODEL US37ACG)**

References: TM 5-4320-272-14 and C9100-IL

Reporting errors and recommending improvements. You can improve this manual. If you find any mistakes or if you know of a way to improve the procedures, please let us know. Mail your letter or DA Form 2028 (Recommended Changes to Publications and Blank Forms) directly to Commander, U.S. Army Troop Support Command, ATTN: AMSTR-MMTS, 4300 Goodfellow Boulevard, St. Louis, MO 63120-1798. A reply will be furnished to you.

This LO is for Operator/crew (C) or Unit (O) maintenance. Lube intervals (on-condition or hard time) are based on normal operation. Lube more during constant use, and less during periods of low activity. Use correct grade of lubricant for seasonal temperature expected.

Intervals (on-condition or hard time) and the related work-hour times are based on normal operation. The work-hour specified is the time you need to do all the services prescribed for a particular interval.

On-condition (OC) oil sample intervals shall be applied unless changed by the Army Oil Analysis Program (AOAP) laboratory. Change the hard time interval if your lubricants are contaminated or if you are operating the equipment under adverse conditions, including longer than usual operating hours.

The hard time interval may be extended during periods of low activity. If extended, adequate preservation precautions must be taken. Hard time intervals will be applied in the event AOAP laboratory support is not available or required.

Ensure Pumping Assembly is level before checking oil levels.

Lubricate after fording, or as soon after as unit movement permits.

On the picture a dash line (--) means lube points on both sides.

Clean parts with dry cleaning solvent (SD), type II or equivalent. Dry before lubricating. Drain oils while they are warm.

Before you start your lube service:

**ALWAYS**

**NEVER**

- a. Clean grease fittings before lubrication.
- b. Use the lubrication order as your guide.

- a. Use wrong type/grade grease.
- b. Use too much lubricant.

DISTRIBUTION STATEMENT A -Approved for public release; distribution is unlimited.

*TOTAL WORK-HR		*TOTAL WORK-HR	
INTERVAL	WORK-HR	INTERVAL	WORK-HR
10	0.2		
50	0.5	1000	2.0

\* The time specified is the time required to perform all services at the particular interval (on-condition or hard time).

**INTERVAL • LUBRICANT**

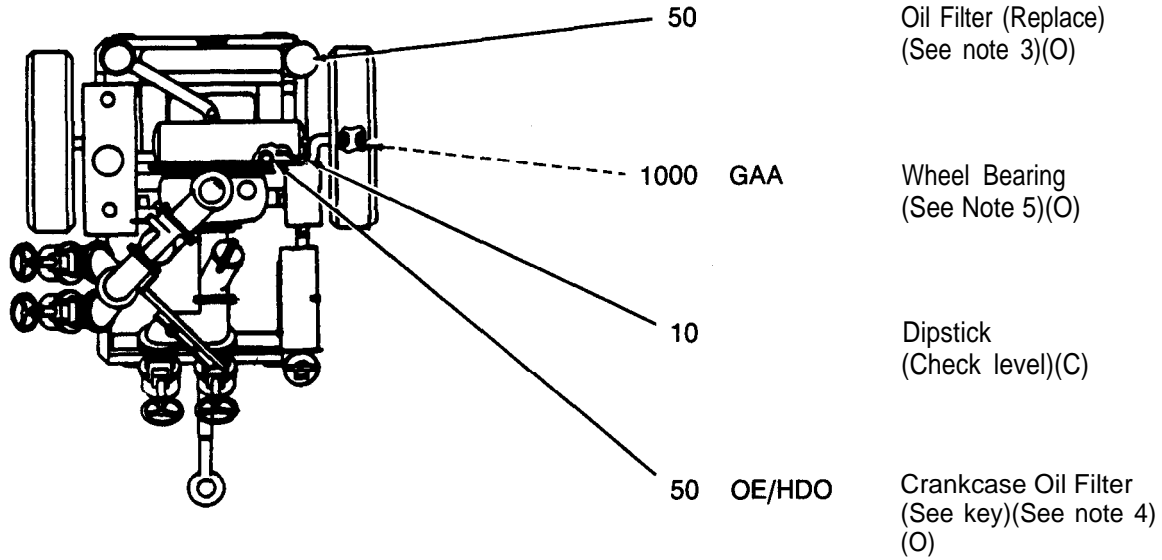

**KEY**

Lubricants	REFILL CAPACITY (APP)	EXPECTED TEMPERATURES																	INTERVALS			
		°F	<-50	-40	-30	-20	-10	0	10	20	30	40	50	60	70	80	90	100		110	120	
OE/HDO (MIL-L-2104) Lubricating Oil, ICE, Combat/Tactical Service	Crankcase Oil Filter & Lines	5 qt (4.7L) 1 qt (0.95L)																			OE/HDO-30 (0-238) OE/HDO-I5/40 (0-1256)	INTERVALS GIVEN ARE IN HOURS OF NORMAL OPERATION
OE/Lubricating Oil, ICE, Arctic	Oil Can Points																			OE/Lubricating Oil, ICE, Arctic		
GAA (MIL-G-10924) Grease, Automotive and Artillery	Wheel Bearing																				ALL TEMPERATURES	

**NOTES**

1. FOR OPERATION OF EQUIPMENT IN PROTRACTED COLD TEMPERATURES BELOW -10°F (-23°C). Remove lubricants prescribed in the key for temperatures above -10°F (-23°C). Clean parts with SOLVENT, dry cleaning. Relubricate with lubricants specified in the key for temperatures below -10°F (-23°C).
2. OIL CAN POINTS. Every 250 hours lubricate carburetor and governor linkage, adjusting screws, and trailer stand with OE/HDO.
3. OIL FILTER. Every time crankcase is drained, or 50 hours, remove and discard oil filter. Install new filter.
4. CRANKCASE. Check level daily. Drain and refill every 50 hours. Capacity: 5 quarts (4.7L) (6 quarts (5.7L) with oil filter change).
5. WHEEL BEARING. Remove wheel and hub, clean, inspect and lubricate bearings and reassemble.

Copy of this Lubrication Order will remain with the equipment at all times; instructions contained herein are mandatory.

By Order of the Secretary of the Army:

Official:

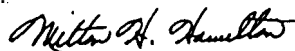

MILTON H. HAMILTON  
*Administrative Assistant to the  
Secretary of the Army*  
00446

GORDON R. SULLIVAN  
*General, United States Army  
Chief of Staff*

Distribution:

To be distributed in accordance with DA Form 12-25E, (qty rqr block no. 4278)



This fine document...

Was brought to you by me:



## [Liberated Manuals -- free army and government manuals](#)

Why do I do it? I am tired of sleazy CD-ROM sellers, who take publicly available information, slap “watermarks” and other junk on it, and sell it. Those masters of search engine manipulation make sure that their sites that sell free information, come up first in search engines. They did not create it... They did not even scan it... Why should they get your money? Why are not letting you give those free manuals to your friends?

I am setting this document FREE. This document was made by the US Government and is NOT protected by Copyright. Feel free to share, republish, sell and so on.

I am not asking you for donations, fees or handouts. If you can, please provide a link to [liberatedmanuals.com](http://liberatedmanuals.com), so that free manuals come up first in search engines:

<A HREF=<http://www.liberatedmanuals.com/>>Free Military and Government Manuals</A>

- Sincerely  
Igor Chudov  
<http://igor.chudov.com/>
- [Chicago Machinery Movers](#)