

**PUMP, CENTRIFUGAL, POL, GED, 6 IN. 1120 GPM,  
SKID MOUNTED  
(BARNES MODEL US67CCG) W/ENGINE  
CONTINENTAL  
MODEL FS 244-06097P**

Reference: C900-IL

Intervals and related task-hour times are based on normal hours of operation. The task-hour time specified is the time you need to do all the services prescribed for a particular interval. Change the interval if your lubricants are contaminated or if you are operating the equipment under adverse operating conditions, including longer-than-usual operating hours. You may extend the interval during periods of low activity, but you must take adequate preservation precautions.

Clean fittings before lubricating. Relubricate all areas exposed to water after amphibious operation. Lubricate points indicated by dotted arrow shaft on both sides of equipment. Clean parts with SOLVENT, dry cleaning, or with OIL, fuel, diesel. Dry before lubricating. Drain crankcase when HOT. Fill and check level. The lowest level of maintenance authorized to lubricate a point is indicated by one of the following: (C) operator/crew, or (O) organizational maintenance.

You can improve this publication by calling attention to errors and by recommending improvements and by stating your reasons for the recommendations. Your letter or DA Form 2028 (Recommended Changes to Publications and Forms) should be mailed directly to Commander, U. S. Army Troop Support Command, ATTN: DRSTS-MPP, 4300 Goodfellow Blvd. , St. Louis, MO. 63120. A reply will be furnished directly to you.

\*The time specified is the time required to perform all services at the particular interval.

FOLD

FOLD

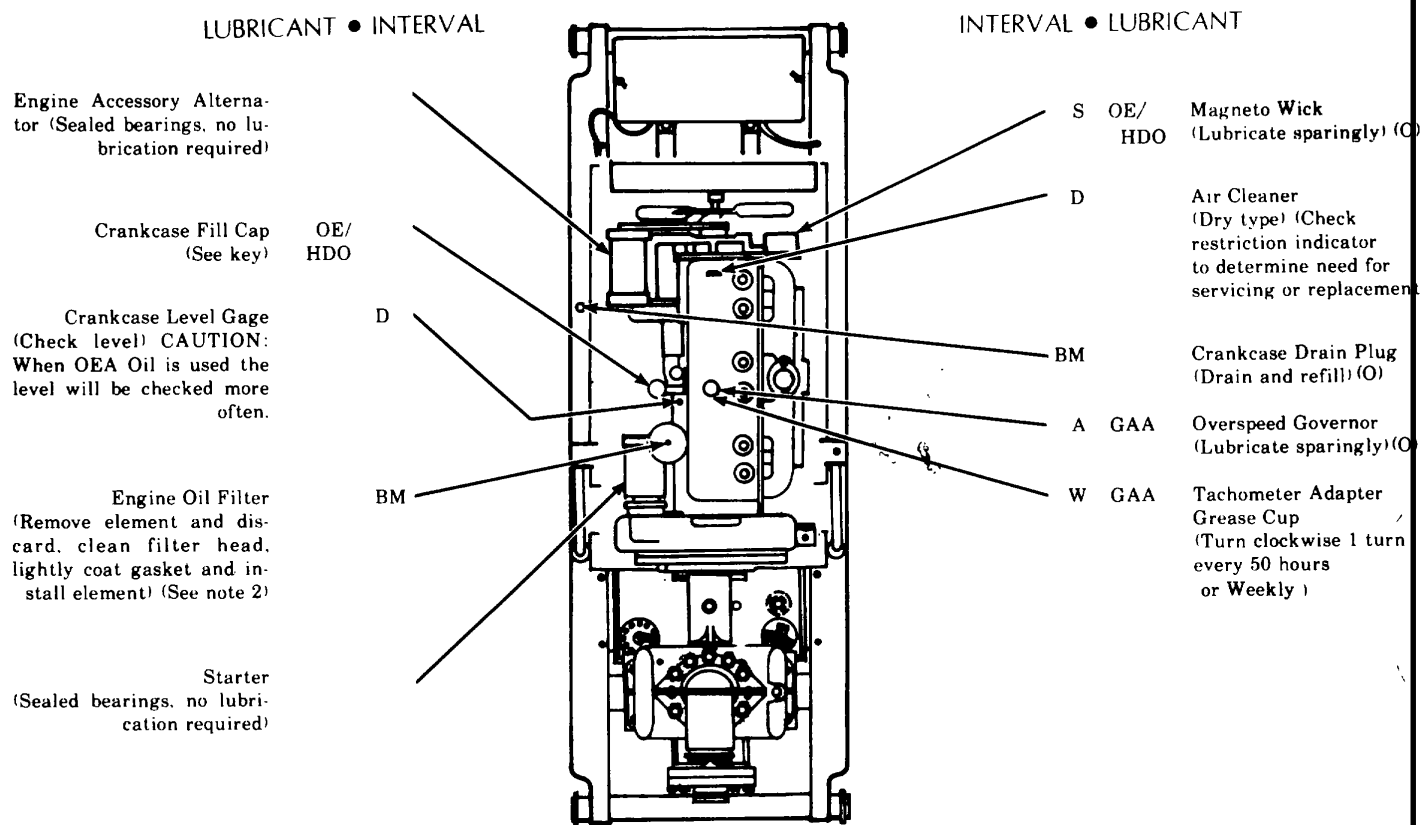

*TOTAL TASK HOURS		*TOTAL TASK HOURS	
INTERVAL	TASK-HOURS	INTERVAL	TASK-HOURS
D	0.5	S	3.0
W	1.5	A	4.0
B-M	0.25		

-KEY-

LUBRICANTS	CAPACITY	EXPECTED TEMPERATURES			INTERVALS
		Above +32°F Above 0°C	+40°F to -10°F + 5°C to -23°C	0°F to -65°F -18°C to -50°C	
OE/HDO Oil, Engine MIL-L-2104 Heavy Duty,					For Arctic Operation Refer to TM 9-207
OE-HDO Crankcase MIL-L-2104	5 112 qt 5. 20 liters				
OE-HDO Oil Can Points MIL-L-2104		OE-HDO 30	OE/HDO	OEAAPG-PD-1	
OEA/APG-PD-1 Oil, Engine Subzero					
GAA-GREASE, Automotive MIL-G-10924 and Artillery			ALL TEMPERATURES		

**NOTES:**

- FOR OPERATION OF EQUIPMENT IN PROTRACTED COLD TEMPERATURES BELOW - 100 F (-230 C. ) Remove lubricants prescribed in the key for temperatures above 100 F (-23° C. ) Relubricate with lubricants specified in the key for temperatures below -10° F (-23° C).
- OIL FILTER. Every 1000 miles, 100 hours, or BiMonthly service filter element. After installing new filter element, fill crankcase, operate engine five minutes, check housing for leaks, check crankcase oil level and bring to full mark.
- OIL CAN POINTS. Every 500 miles, 60 hours, or weekly, lubricate pivot points and all adjusting threads with OE/ HDO.
- LUBRICANTS. The following is a list of lubricants with the Military Symbols and applicable specification numbers.  
OE/HDO MIL-L-2104 OEA/APG-PD-  
GAA MIL-G-10924

Copy of this Lubrication Order will remain with the equipment at all times; instructions contained herein are mandatory.

BY ORDER OF THE SECRETARY OF THE ARMY

**BERNARD W. ROGERS**  
General, United States Army  
Chief of Staff

OFFICIAL:

**PAUL T. SMITH**  
Major General, United States Army  
The Adjutant General

FOLD

FOLD

DISTRIBUTION: To be distributed in accordance with DA Form 12-25A, Operator maintenance requirements for Petroleum Distribution.

\* U. S. GOVERNMENT PRINTING OFFICE : 1994 O - 300-721 (00352)

**PIN: 018011-000**





This fine document...

Was brought to you by me:



## [Liberated Manuals -- free army and government manuals](#)

Why do I do it? I am tired of sleazy CD-ROM sellers, who take publicly available information, slap “watermarks” and other junk on it, and sell it. Those masters of search engine manipulation make sure that their sites that sell free information, come up first in search engines. They did not create it... They did not even scan it... Why should they get your money? Why are not letting you give those free manuals to your friends?

I am setting this document FREE. This document was made by the US Government and is NOT protected by Copyright. Feel free to share, republish, sell and so on.

I am not asking you for donations, fees or handouts. If you can, please provide a link to [liberatedmanuals.com](http://liberatedmanuals.com), so that free manuals come up first in search engines:

<A HREF=<http://www.liberatedmanuals.com/>>Free Military and Government Manuals</A>

- Sincerely  
Igor Chudov  
<http://igor.chudov.com/>
- [Chicago Machinery Movers](#)