

ORDER

26 MARCH 1971 (Supersedes L.05-3810-201-12-4, dtd 9 Feb 1968 and L05-3810-206-12-4, dtd 18 Mar 1968)

**CRANE-SHOVEL, BASIC UNIT, CRAWLER MOUNTED, 40 TON, 2 CU YD,
DIESEL DRIVEN, (HARNISCHFEGER MODEL 855 BG, 855 BG-2 AND
855 BG-3) W/HARNISCHFEGER ENGINE MODEL 687C-18-ES AND
CATERPILLAR ENGINE MODELS D333TA AND D333C**

Reference L05-3810-206-12-1,-3, and -5 C9100-IL

Intervals are based on normal hours of operation. Adjust to compensate for abnormal operations and severe conditions. During Inactive periods sufficient lubrication must be performed for adequate preservation.

Clean parts with SOLVENT, dry-cleaning, or with OIL, fuel, Diesel. Dry before lubricating.

Clean fittings before lubrication. sides of equipment.

Lubricate points Indicated by dotted arrow shafts on both

Relubricate after washing or fording.

A dotted circle Indicates a drain below.

Drain gearcases when hot. Fill and check level.

LUBRICANT • INTERVAL

INTERVAL • LUBRICANT

FOLD

FOLD

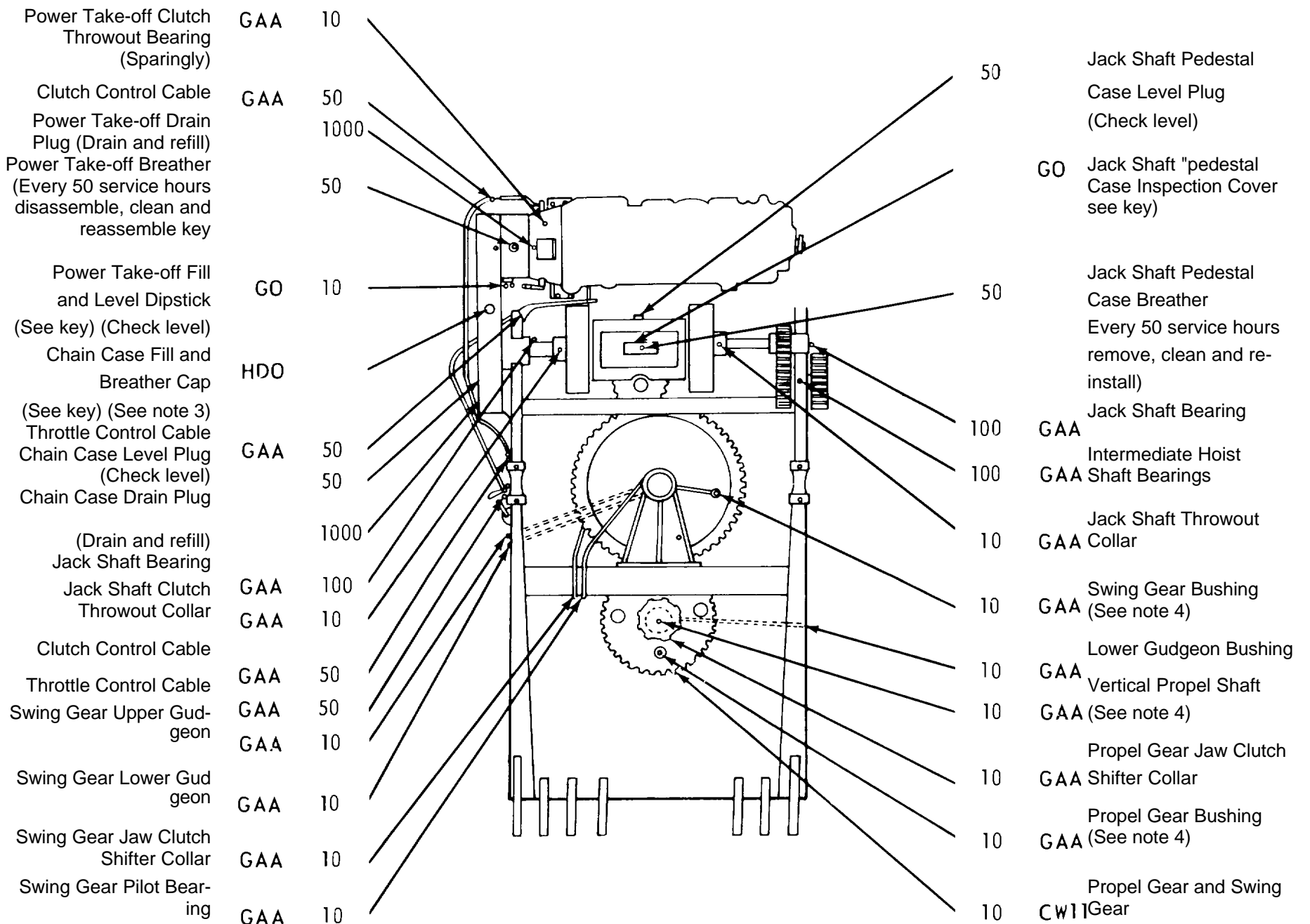

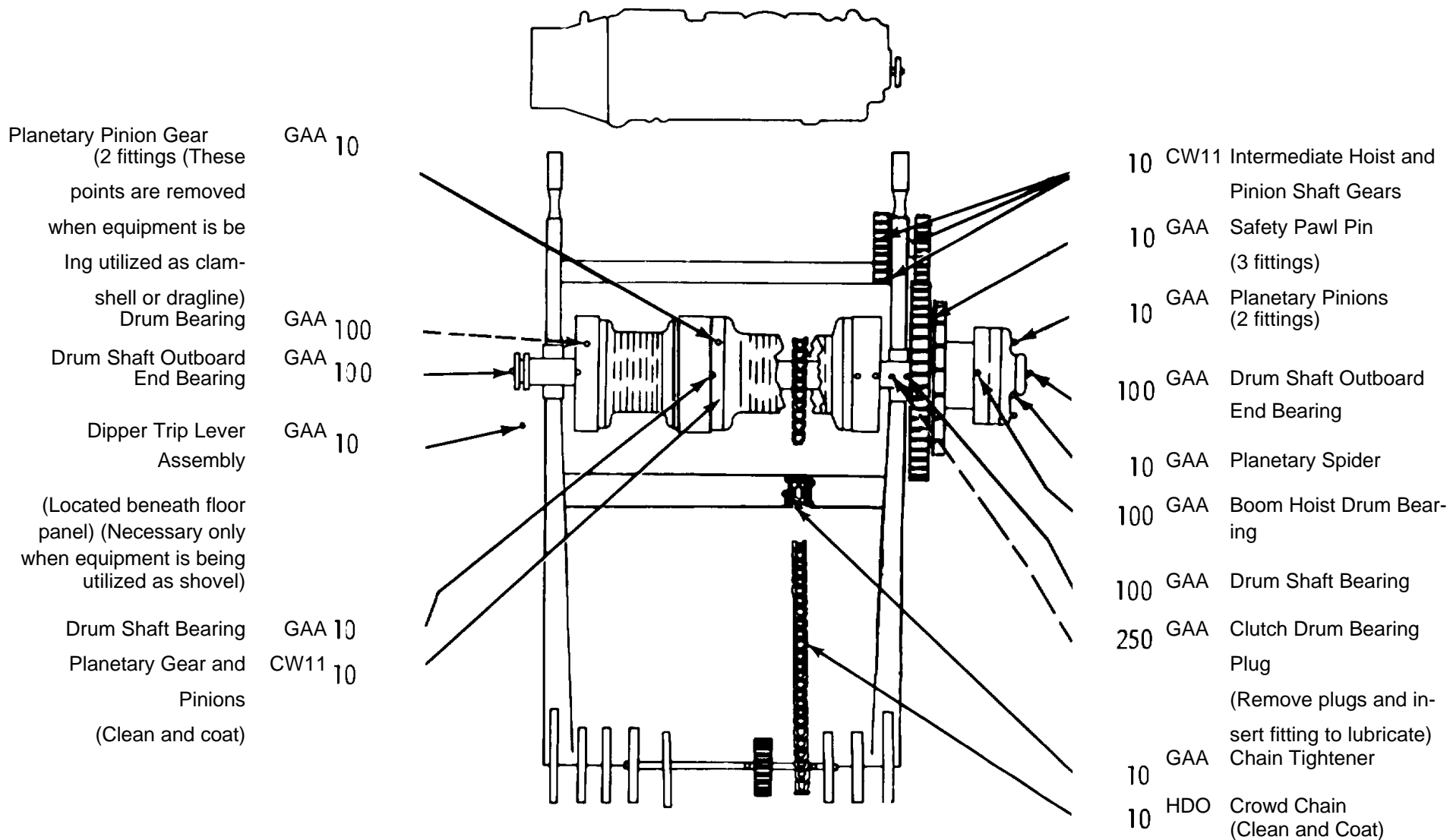

FOLD

FOLD

-KEY-

LUBRICANTS	CAPACITY	EXPECTED TEMPERATURES			INTERVALS
		Above +32° F	+40° F to -10° F	0° F to -65° F	
HDO-OIL, Engine Heavy Duty					Intervals given are In hours of normal operation
Chain Case	14 qts	HDO 30	HDO 10	OES	
Oil Can Points					
OES-Oil, Engine, Sub-zero					
GO-LUBRICATING OIL, Gear					
Power Take-off	8 qts	GO 90	GO 90	GOS	
Jack Shaft Pedestal Case	24 qts				
GOS-LUBRICATING OIL, Gear, Sub-zero					
CW-11-B LUBRICATING OIL, Exposed Gear		ALL TEMPERATURES			
GAA-GREASE, Automotive and Artillery					

NOTES:

- FOR OPERATION OF EQUIPMENT IN PROTRACTED COLD TEMPERATURES BELOW - 10° F.** Remove lubricants prescribed in the key for temperatures above - 10° F. Relubricate with lubricants specified in the key for temperatures below - 1° F.
- OIL CAN POINTS.** Every 10 service hours lubricate all linkage, pins and clevises with HDO.
- CHAIN CASE BREATHER.** Every 250 service hours remove breather cap and clean in approved cleaning SOLVENT. Dry, reoil and re-install.
- TRAVELING.** When traveling, lubricate the following points every 2 service hours, swing gear bushing, vertical propel shaft and propel gear bushing.

5. LUBRICANTS The following is a list of lubricants with the Military Symbols and applicable Specification numbers.

- HDO MIL-L-45199
- GO MIL-L-2105
- OES MIL-L-10295
- GOS MIL-L-10324
- GAA MIL-L-10924
- CW-11B VV-L-751

Copy of this Lubrication Order will remain with the equipment at all times, instructions contained herein are mandatory.

BY ORDER OF THE SECRETARY OF THE ARMY.
 W. C. WESTMORELAND
 General, United States Army,
 Chief of Staff

OFFICIAL

KENNETH G. WICKHAM
 Major General, United States Army,
 The Adjutant General.

RECOMMENDED CHANGES TO EQUIPMENT TECHNICAL PUBLICATIONS



SOMETHING WRONG WITH THIS PUBLICATION?

THEN... JOT DOWN THE DOPE ABOUT IT ON THIS FORM, CAREFULLY TEAR IT OUT, FOLD IT AND DROP IT IN THE MAIL!

FROM: (PRINT YOUR UNIT'S COMPLETE ADDRESS)

DATE SENT

PUBLICATION NUMBER	PUBLICATION DATE	PUBLICATION TITLE
--------------------	------------------	-------------------

BE EXACT... PIN-POINT WHERE IT IS				IN THIS SPACE TELL WHAT IS WRONG AND WHAT SHOULD BE DONE ABOUT IT:
PAGE NO.	PARA-GRAPH	FIGURE NO.	TABLE NO.	

PRINTED NAME, GRADE OR TITLE, AND TELEPHONE NUMBER	SIGN HERE:
--	------------

TEAR ALONG PERFORATED LINE

DA FORM 2028-2
JUL 79

PREVIOUS EDITIONS ARE OBSOLETE.

P.S.—IF YOUR OUTFIT WANTS TO KNOW ABOUT YOUR RECOMMENDATION MAKE A CARBON COPY OF THIS AND GIVE IT TO YOUR HEADQUARTERS.

This fine document...

Was brought to you by me:



[Liberated Manuals -- free army and government manuals](#)

Why do I do it? I am tired of sleazy CD-ROM sellers, who take publicly available information, slap “watermarks” and other junk on it, and sell it. Those masters of search engine manipulation make sure that their sites that sell free information, come up first in search engines. They did not create it... They did not even scan it... Why should they get your money? Why are not letting you give those free manuals to your friends?

I am setting this document FREE. This document was made by the US Government and is NOT protected by Copyright. Feel free to share, republish, sell and so on.

I am not asking you for donations, fees or handouts. If you can, please provide a link to liberatedmanuals.com, so that free manuals come up first in search engines:

<A HREF=<http://www.liberatedmanuals.com/>>Free Military and Government Manuals

- Sincerely
Igor Chudov
<http://igor.chudov.com/>
- [Chicago Machinery Movers](#)