

26 MARCH 1971 (Supersedes LO5-3810-201-12-3, dtd 9 Feb 1968 and LO5-3810-206-12-3, dtd 18 Mar 1968)

**CRANE-SHOVEL, BASIC UNIT, CRAWLER MOUNTED, 40 TON, 2 CU YD,
DIESEL DRIVEN, (HARNISCHFEGER MODEL 855 BG, 855 BG-2 AND
855 BG-3) W/HARNISCHFEGER ENGINE MODEL 687C-18-ES AND
CATERPILLAR ENGINE MODELS D333TA AND D333C**

Intervals are based on normal hours of operation. Adjust to compensate for abnormal operations and severe conditions. During inactive periods sufficient lubrication must be performed for adequate preservation.

Clean parts with SOLVENT, dry-cleaning, or with OIL, fuel, Diesel. Dry before lubricating.

Lubricate points indicated by dotted arrow shafts on both sides of equipment.

Clean fittings before lubricating.

Relubricate after washing or fording.

LUBRICANT ● INTERVAL

Dragline Dump Sheave GAA 10

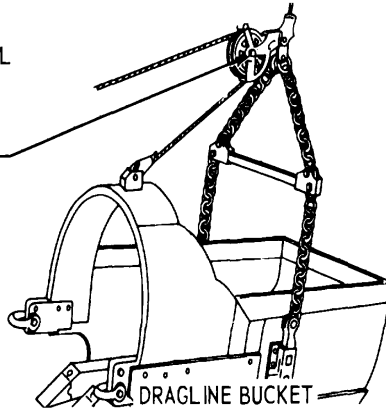

FOLD

FOLD

INTERVAL ● LUBRICANT

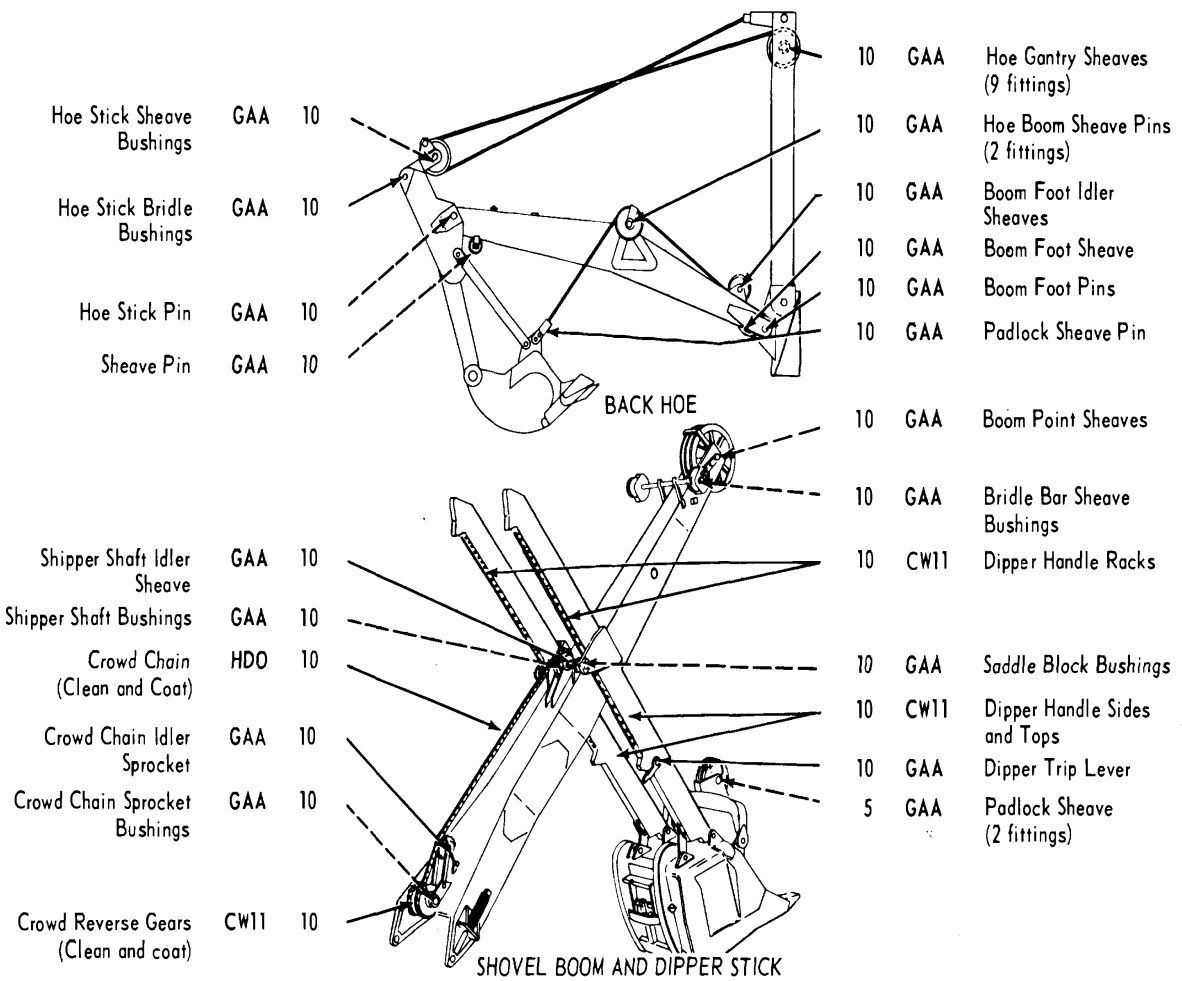

LUBRICANT●INTERVAL

INTER

VAL●LUBRICANT

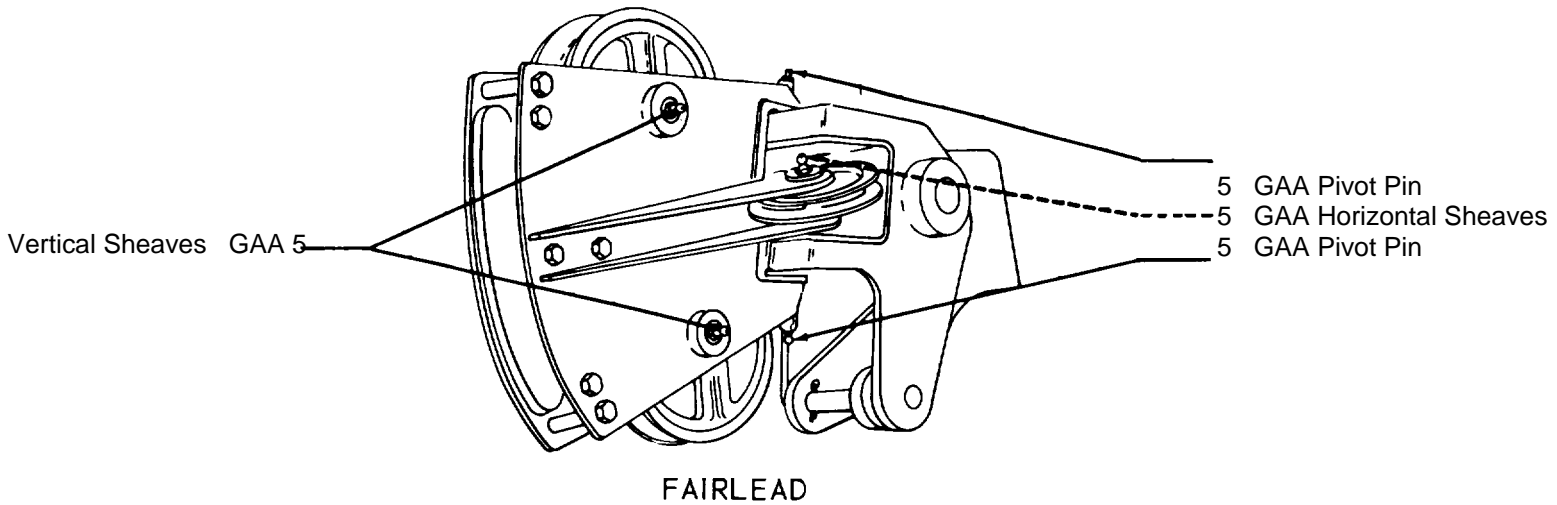
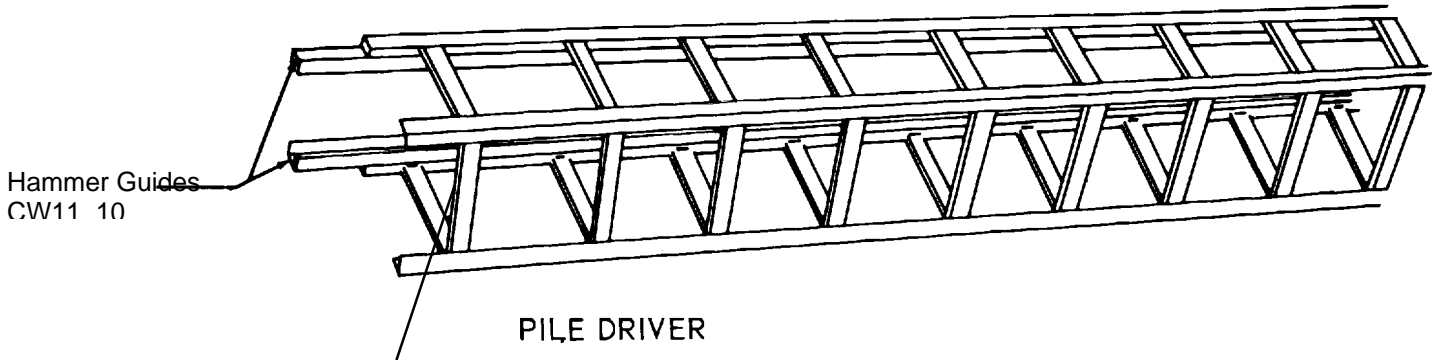

-KEY-

LUBRICANTS	CAPACITY	EXPECTED TEMPERATURES	INTERVALS
HDO-OIL, Engine, Heavy Duty Oil Can Points		Above +32°F +40°F to -10°F 0°F to -65°F	Intervals give are in hours of normal operation
CW-11B-LUBRICANT, Exposed Gears GAA-GREASE, Automotvie and Artillery		HDO 30 ALL TEMPERATURES	

NOTES

- FOR OPERATION OF EQUIPMENT IN PROTRACTED COLD TEMPERATURES BELOW -10°F. Remove lubricants prescribed in key for temperatures above -10°F. Relubricate with lubricants specified in the key for temperatures below -10°F.
- OIL CAN POINTS. Every 10 service hours lubricate all linkage, pins and clevises with HDO.
- CABLES. Keep cables clean and lubricated with HDO.
CAUTION: Do not lubricate cables coming in contact with excavated materials.
- LUBRICANTS. The following is a list of lubricants with the Military Symbols and applicable specification numbers.

HDS MIL-L-45199 GAA MIL-G-10924 CW-11B VV-L-751

Copy of the Lubrication Order will remain with the equipment at all times; instructions contained herein are mandatory.

BY ORDER OF THE SECRETARY OF THE ARMY:

W.C. WESTMORELAND
General, United States Army
Chief of Staff

OFFICIAL:

KENNETH G. WICKHAM
Major General, United States Army
The Adjutant General

Lo 5-3810-206-12-3 DISTRIBUTION: To be distributed in accordance with DA Form 12-23, Sec II (qty rqr Block #349). Organizational maintenance requirements for Crane Shovels, Crawlers, 40 Ton.

This fine document...

Was brought to you by me:



[Liberated Manuals -- free army and government manuals](#)

Why do I do it? I am tired of sleazy CD-ROM sellers, who take publicly available information, slap “watermarks” and other junk on it, and sell it. Those masters of search engine manipulation make sure that their sites that sell free information, come up first in search engines. They did not create it... They did not even scan it... Why should they get your money? Why are not letting you give those free manuals to your friends?

I am setting this document FREE. This document was made by the US Government and is NOT protected by Copyright. Feel free to share, republish, sell and so on.

I am not asking you for donations, fees or handouts. If you can, please provide a link to liberatedmanuals.com, so that free manuals come up first in search engines:

<A HREF=<http://www.liberatedmanuals.com/>>Free Military and Government Manuals

- Sincerely
Igor Chudov
<http://igor.chudov.com/>
- [Chicago Machinery Movers](#)