

LUBRICATION ORDER
9 JAN 84

(Supersedes LO 5-3805-237-12 -1, JANUARY 1974; AND -12-2, AND -3, 1 MAY 1967)

**GRADER, ROAD, MOTORIZED: DIESEL
ENGINE DRIVEN; 13,300 LB PRESSURE AT
BLADE; 12 FT BLADE; 6 WHEELS, 4 DRIVING,
2 STEERABLE; LEANING FRONT WHEELS;
W/SCARIFIER (LETOURNEAU-WESTINGHOUSE
MODEL 440 HA) NSN 3805-00-931-7881**

Reference: TM 5-3805-237-12, and FEDERAL SUPPLY CATALOG C9100-1L.

Intervals (on-condition or hard time) and the related man-hour times are based on normal operation. The man-hour time specified is the time you need to do all the services prescribed for a particular interval. On condition (OC) oil sample intervals shall be applied unless changed by the Army Oil Analysis Program (AOAP) laboratory. Change the hard time interval if your lubricants are contaminated or if you are operating the equipment under adverse operating conditions, including longer-than-usual operating hours. The hard time interval may be extended during periods of low activity. If extended, adequate preservation precautions must be taken. Hard time intervals will be applied in the event AOAP laboratory support is not available.

WARNING

Dry cleaning fluid is flammable. Do not use near a flame or excessive heat. Use only with adequate ventilation. Avoid prolonged breathing of vapors and minimize skin contact

Clean parts or fittings with dry cleaning solvent (SD), Type II or equivalent. Dry before lubricating. Dotted arrow shafts indicate lubrication on both sides of equipment. A dotted circle indicates a drain below. Relubricate all items found contaminated after fording or washing.

The lowest level of maintenance authorized to lubricate a point is indicated by one of the following symbols as appropriate: Operator/Crew (C) ; and Organizational Maintenance (O).

Reporting errors and recommending improvements.

You can help improve this manual. If you find any mistakes, or if you know of a way to improve the procedures, please let us know. Mail your letter or DA Form 2028 (Recommended Changes to Publications and Blank Forms) direct to: Commander, US Army Tank-Automotive Command, ATTN: DRSTA-MB, Warren, MI 48090. A reply will be furnished to you.

*The time specified is the time required to perform all services at the particular interval (on-condition or hard times).

TOTAL MAN-HOURS		TOTAL MAN-HOURS	
INTERVAL	MAN-HOURS	INTERVAL	MAN-HOURS
10	1.6	250	3.5
50	.2	500	1.0
100	1.0	1000	3.0

TA 220136

LUBRICANT • INTERVAL

INTERVAL • LUBRICANT

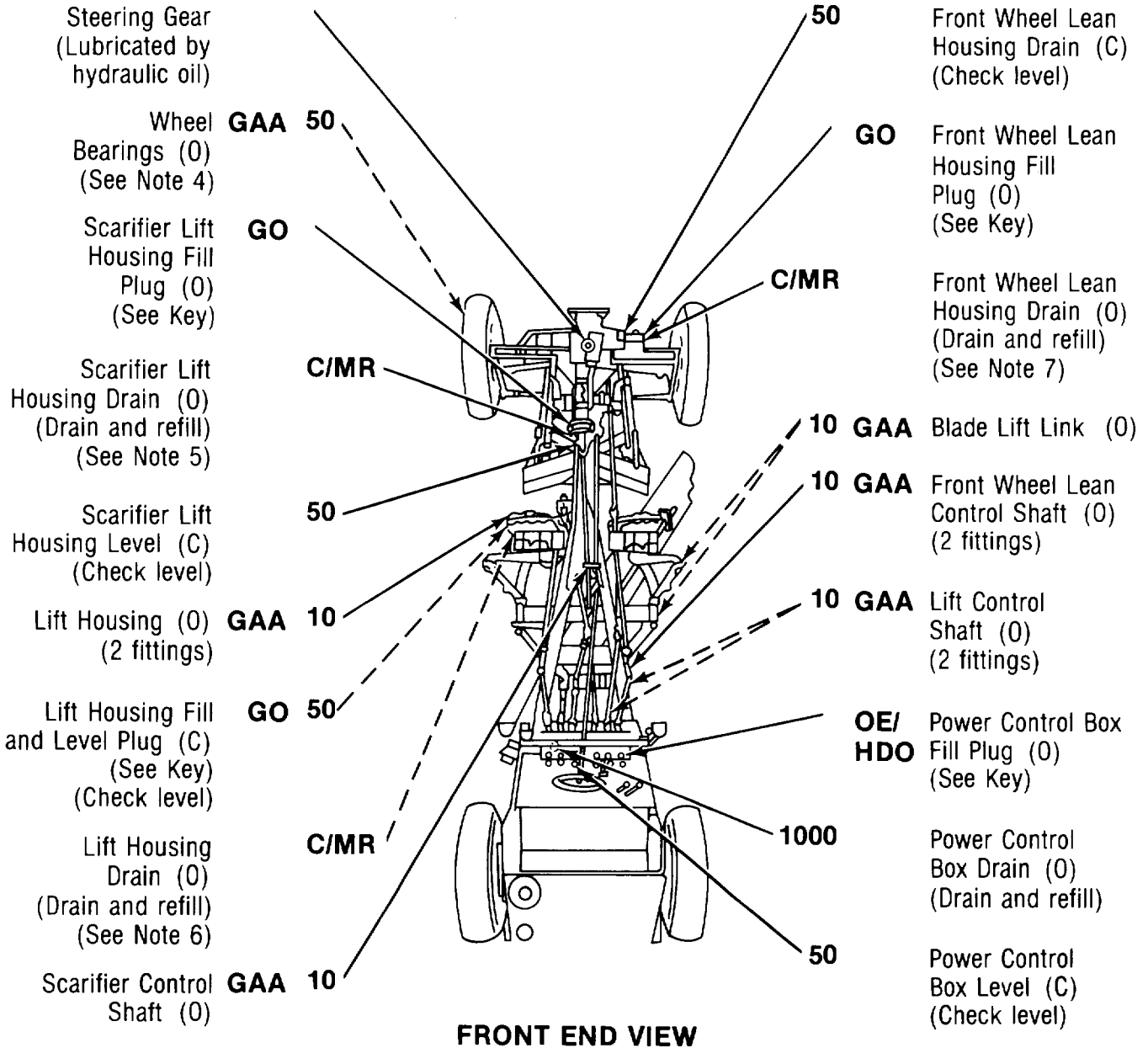

FRONT END VIEW

LUBRICANT • INTERVAL

INTERVAL • LUBRICANT

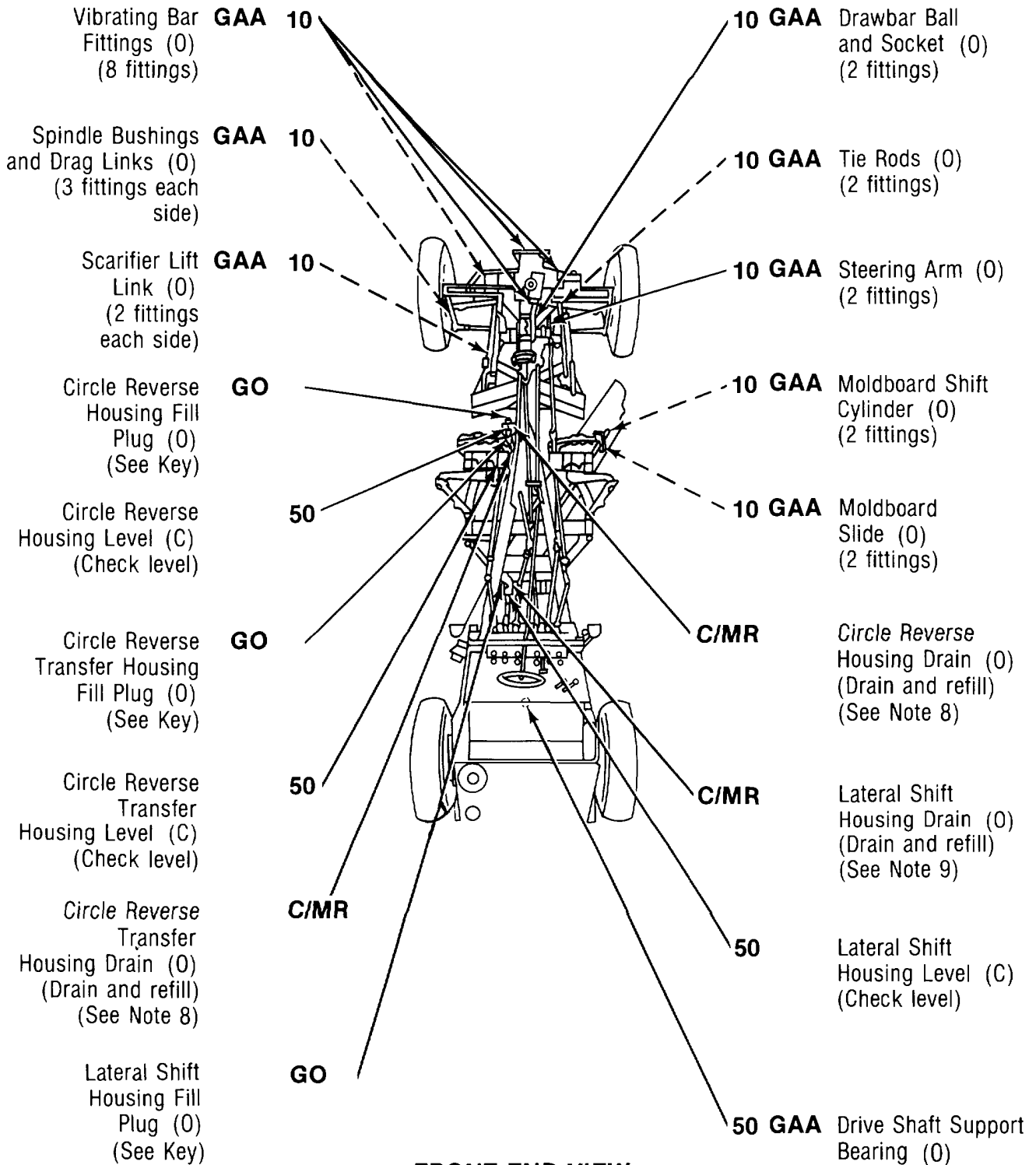

FRONT END VIEW

LUBRICANT • INTERVAL

INTERVAL • LUBRICANT

Scarifier Gear Reduction Housing Fill Plug (0) (See Key) **GO**

Scarifier Gear Reduction Housing Drain (0) (Drain and refill) (See Note 5) **C/MR**

Scarifier Gear Reduction Level (C) (Check level) **50**

Lift Gear Reduction Housing Fill Plug (0) (See Key) **GO**

Lift Gear Reduction Housing Drain (0) (Drain and refill) (See Note 6) **C/MR**

Lift Gear Reduction Housing Level (C) (Check level) **50**

Lateral Shift Link (0) (2 fittings) **GAA 10**

Axle Bearings (C) (2 fittings each side) (Sparingly) **GAA 50**

10 GAA Steering Control Shaft (0) (2 fittings)

10 GO Circle Flange (0) (See Note 16)

10 GAA Circle Reverse Control Shaft (0) (3 fittings)

GO Power Control Box Vertical Drive Housing Fill Plug (0) (See Key)

Power Control Box Vertical Drive Housing Drain (0) (Drain and refill) (See Note 9)

Power Control Box Vertical Drive Housing Level (C) (Check level)

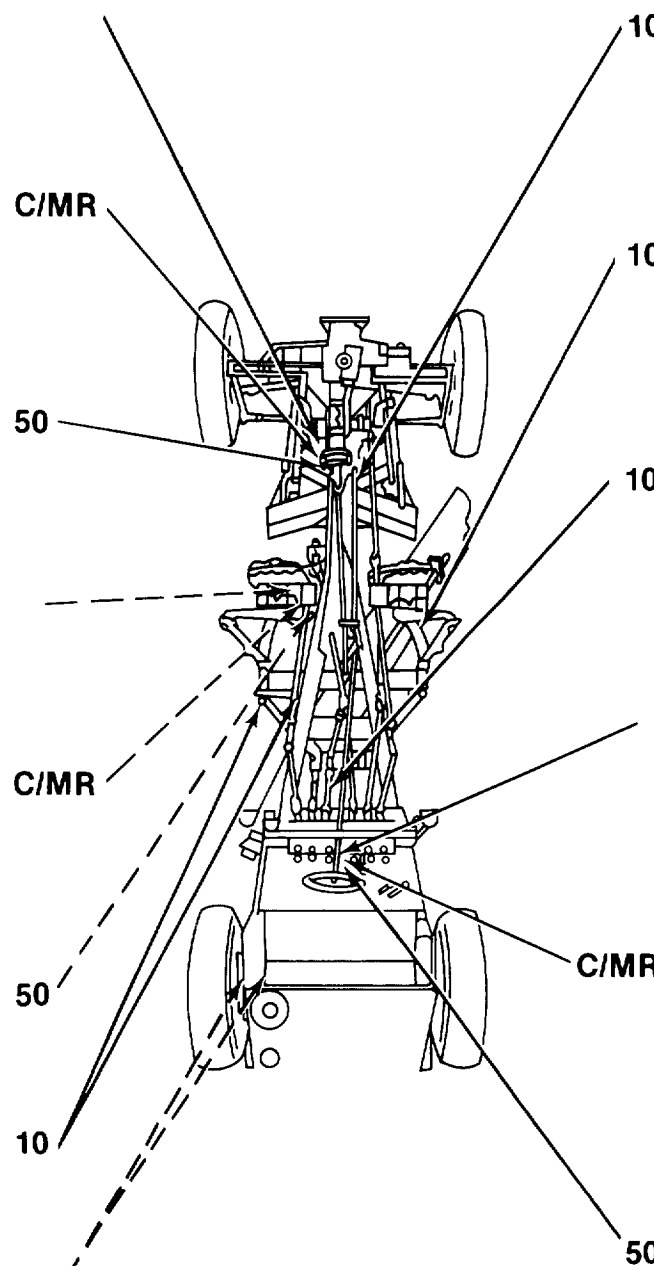

FRONT END VIEW

LUBRICANT • INTERVAL

INTERVAL • LUBRICANT

Control Shaft (C) **GAA** 50

Upper Transmission and Shifter Housing (O) **GO** 50
Fill Plug (See Key)

Hydraulic Reservoir Level (C) **50**
(Check level)

Reservoir Breather (O) **50**
(Remove, Clean, Reoil, Install)

Hydraulic Reservoir Fill and Filter (O) **OE/ HDO** 500
(See Key)
(See Note 10)

Hydraulic Reservoir Drain (O) **1000**
(Drain and refill)

C/MR

Upper Transmission and Shifter Housing Drain (O)
(Drain and refill)
(See Note 11)

50

Upper Transmission Level (C)
(Check level)

50 GO

Lower Transmission Fill and Level Plug (O)
(See Key)
(Check level)

C/MR

Lower Transmission Drain (O)
(Drain and refill)
(See Note 11)

250 GAA Pintle Hook (O)
(3 fittings)

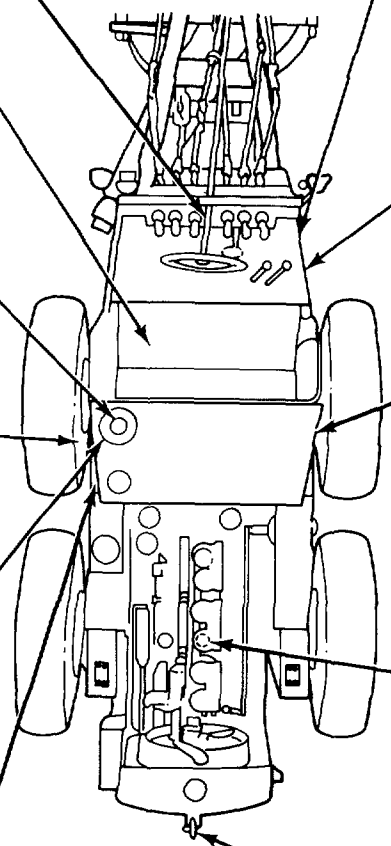

REAR END VIEW

LUBRICANT • INTERVAL

INTERVAL • LUBRICANT

Master Cylinder Fill and Level (C)
(See Key)
(Check level)
BFS 10

Clutch Bearings (0)
(2 fittings)
(Sparingly)
GAA 50

Engine Oil Level Gage (C)
(Check level)
(See Note 12)
10

Engine Crankcase Fill (C)
(See Key)
**OE/
HDO**

Axle Bearings (0)
(2 fittings each side)
(Sparingly)
GAA 50

Engine Oil Filter (0)
(Change Element)
(See Note 13)
**OC
or
100**

10 GAA Brake Linkage (0)
(5 fittings)

10 GAA Throttle Linkage (0)
(6 fittings)

250 GAA Drive Shaft Spline Joints (0)

50 GAA Outboard and Inboard Bearings (0)
(Sparingly)

50 Tandem Drive Level (C)
(Check level)

**OE/
HDO** Tandem Drive Fill (C)
(See Key)

1000 Tandem Drive Drain (0)
(Drain and refill)
(See Note 14)

**OC
or
100** Engine Oil Drain (0)
(Drain and refill)
(See Note 15)

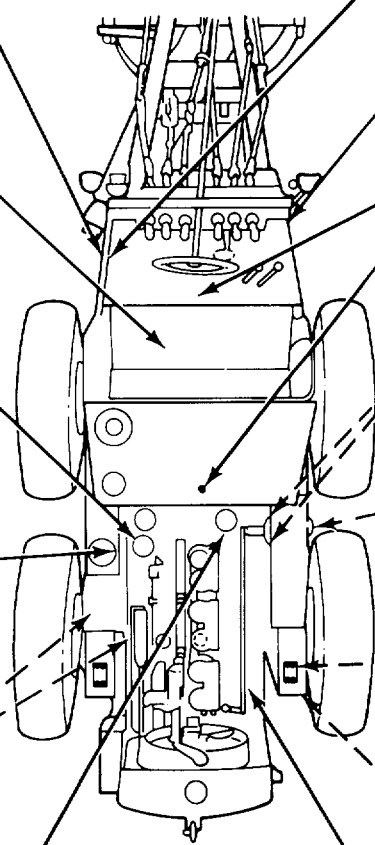

REAR END VIEW

*- KEY-

LUBRICANTS	CAPACITY	EXPECTED TEMPERATURES ⁹⁻²⁰⁷			INTERVALS
		Above +15°F (Above -9°)	+ 40°F to -15° F (+ 4° to -26°)	+40°F to -65°F (+4° to -54°)	
OE/ - Lubricating Oil, Gear Multipurpose - Scarifier Lift Housing - Power Box Vertical Drive Shaft Housing - Upper Transmission - Lower Transmission	12-1/2 qts. (11.83 L) 4 qts (3.78 L) 11 qts. (10.40 L) 50 qts. (47.73 L)	GO 85W/140	GO 80W/90	GO 75W	For Arctic operation refer to FM - C/MR - Condition Monitor OC - On Condition (AOAP) Intervals given are in hours of normal operation.
BFS - Brake, Fluid Silicone Automotive - Master Cylinder	1-1/4 QTS. (1.18 L)	ALL TEMPERATURES			
GAA - Grease Automotive and Artillery		ALL TEMPERATURES			

* See Note 7 for lubricant specification number.

NOTES:

1. ARMY OIL ANALYSIS PROGRAM (AOAP). For Active Army units, obtain samples from engine every 50 hours of operation or 60 days (whichever comes first). Reserve and National Guard activities will use 50 hours or 120 days as the prescribed sample intervals. Reserve and National Guard equipment in frequent use during active training period will adhere to the schedule for Active Army units. As a minimum, one sample from each units' two week active training period will be submitted for each item of equipment. Send these samples to the nearest AOAP laboratory. Refer to TB 43-0210 for sampling instructions. When or if AOAP laboratory support is unavailable, hard time intervals will apply.

NOTE

- Do not hold oil samples. Submit oil samples as soon as they have been taken.
- Seasonal oil changes will be made due to expected temperatures. (See Key.)

2. FOR OPERATION OF EQUIPMENT IN PROTRACTED COLD TEMPERATURES BELOW -15°F (-26°C). Remove lubricants prescribed in Key for temperatures above -15°F (-26°C). Relubricate with lubricants specified in Key for temperatures below -15°F (-26°C). If OEA lubricant is required

NOTES - CONTINUED:

to meet the temperature ranges prescribed in the Key, OEA lubricant is to be used in place of OE/HDO-10 lubricant for all temperature ranges where OE/HDO-10 is specified in the Key.

3. OIL CAN POINTS. Each 50 hours lubricate control linkage, pins and clevises, and all exposed adjusting threads with EO/HDO.

4. WHEEL BEARINGS. Each 1000 hours remove, clean, inspect, lubricate and assemble.

5. SCARIFIER LIFT HOUSING/SCARIFIER GEAR REDUCTION HOUSING. Check level each 50 hours. Change gear lubricant only when required by maintenance repair action, contamination by water, or other foreign material. After refill, operate for 5 minutes, check for leaks and bring oil level to fill plug opening.

6. LIFT HOUSING/LIFT GEAR REDUCTION HOUSING. Check level each 50 hours. Change gear lubricant only when required by maintenance repair action, contamination by water, or other foreign material. After refill, operate for 5 minutes, check for leaks and bring oil level to fill plug opening.

7. FRONT WHEEL LEAN HOUSING. Check level each 50 hours. Change gear lubricant only when required by maintenance repair action, contamination by water, or other foreign material. After refill, operate for five minutes, check for leaks and bring oil level to fill plug opening.

8. CIRCLE REVERSE HOUSING/CIRCLE REVERSE TRANSFER HOUSING. Check level each 50 hours. Change gear lubricant only when required by maintenance repair action, contamination by water, or other foreign material. After refill, operate for five minutes, check for leaks and bring oil level to fill plug opening.

9. LATERAL SHIFT HOUSING/POWER CONTROL BOX VERTICAL DRIVE HOUSING. Check level each 50 hours. Change gear lubricant only when required by maintenance repair action, contamination by water, or other foreign material. After refill, operate for 5 minutes, check for leaks and bring oil level to fill plug opening.

10. HYDRAULIC OIL FILTER. Each 500 hours, remove element, clean filter housing and install new element. After replacement, operate hydraulic system for 5 minutes, check for leaks, check level and bring to "FULL" mark.

11. LOWER TRANSMISSION/UPPER TRANSMISSION AND SHIFTER HOUSING. Check level each 50 hours. Change gear lubricant only when required by maintenance repair action, contamination by water, or other foreign material. After refill, operate for 5 minutes, check for leaks and bring oil level to fill plug opening.

12. ENGINE OIL LEVEL HOT OR COLD CHECK. Cold engine, oil level should be at high mark on dipstick. Hot engine, oil level must be between high and low marks on dipstick (allow to set 5 minutes before checking).

13. ENGINE OIL FILTER. Filter is to be replaced each time an engine oil change is directed by AOAP laboratory. After installing new filter element, fill crankcase, operate engine 5 minutes, check housing for leaks, check crankcase oil level and bring to full mark. When AOAP laboratory support is not available, install new filter element each 100 hours.

14. TANDEM DRIVES. Each 1000 hours drain tandems. Place tandems in uphill position and remove tandem level and drain plug.

15. ENGINE. Oil is to be changed each time an engine oil change is directed by

TA 220144

NOTES - CONTINUED:

AOAP laboratory. When AOAP laboratory support is not available, change oil each 100 hours.

16. CIRCLE FLANGE. Clean circle flange with a solution of OE/HDO and Diesel Fuel, mixed one quart (0.946 L) OE/HDO to one gallon (3.78 L) of Diesel Fuel. After cleaning, wipe dry and apply a light coat of GO with a clean rag or shop towel.

17. LUBRICANTS. The following is a list of lubricants with military symbols and applicable specification numbers.

OE/HDO	MIL-L-2104
GO	MIL-L-2105
GAA	MIL-G-10924
OEA	MIL-L-46167
BFS	MIL-B-46176
(SD), Type II	P-D-680

Copy of this Lubrication Order will remain with the equipment at all times, instructions contained herein are mandatory.

By order of the Secretary of the Army:

JOHN A. WICKHAM, JR.
General, United States Army
Chief of Staff

OFFICIAL:

ROBERT M. JOYCE
Major General, United States Army
The Adjutant General

DISTRIBUTION:

To be distributed in accordance with DA Form 12-25B, Operator and Organizational maintenance requirements for Graders.

LO 5-3805-237-12

PIN: 054771-000

This fine document...

Was brought to you by me:



[Liberated Manuals -- free army and government manuals](#)

Why do I do it? I am tired of sleazy CD-ROM sellers, who take publicly available information, slap “watermarks” and other junk on it, and sell it. Those masters of search engine manipulation make sure that their sites that sell free information, come up first in search engines. They did not create it... They did not even scan it... Why should they get your money? Why are not letting you give those free manuals to your friends?

I am setting this document FREE. This document was made by the US Government and is NOT protected by Copyright. Feel free to share, republish, sell and so on.

I am not asking you for donations, fees or handouts. If you can, please provide a link to liberatedmanuals.com, so that free manuals come up first in search engines:

<A HREF=<http://www.liberatedmanuals.com/>>Free Military and Government Manuals

- Sincerely
Igor Chudov
<http://igor.chudov.com/>
- [Chicago Machinery Movers](#)