

21 DECEMBER 83

**SCRAPERS, EARTHMOVING, TOWED; HYDRAULIC OPERATED, 8 CU YD, (MRS MANUFACTURING CO. MODEL MS-100) (NSN 3805-00-051-3139) AND (MODEL MRS-100) (3805-00-418-0115) AIR DROPPABLE AND (3805-00-418-0116) AIR TRANSPORTABLE**

Reference: TM 5-3805-235-13 and FEDERAL SUPPLY CATALOG C9100-1L.

Hard time intervals and the related man-hour times are based on normal operation. The man-hour time specified is the time you need to do all the services prescribed for a particular interval. Change the hard time interval if your lubricants are contaminated or if you are operating the equipment under adverse operating conditions, including longer-than-usual operating hours. The hard time interval may be extended during periods of low activity. If extended, adequate preservation precautions must be taken.

**WARNING**

**Dry cleaning fluid is flammable. Do not use near a flame or excessive heat. Use only with adequate ventilation. Avoid prolonged breathing of vapors and minimize skin contact**

Clean parts or fittings with dry cleaning solvent (SD), Type II or equivalent. Dry before lubricating. Dotted arrow shafts indicate lubrication on both sides of equipment. A dotted circle indicates a drain below. Relubricate all items found contaminated after fording or washing.

The lowest level of maintenance authorized to lubricate a point is indicated by one of the following symbols as appropriate: Operator/Crew (C); and Organizational Maintenance (O).

**Reporting errors and recommending improvements.** You can help us improve this manual. If you find any mistakes, or if you know of a way to improve the procedures, please let us know. Mail your letter or DA Form 2028 (Recommended Changes to Publications and Blank Forms) direct to: Commander, US Army Tank-Automotive Command, ATTN: DRSTA-MB, Warren, MI 48090. A reply will be furnished to you.

\*The time specified is the time required to perform all services at the particular interval.

*TOTAL MAN-HOURS		*TOTAL MAN-HOURS	
INTERVAL	MAN-HOURS	INTERVAL	MAN-HOURS
10	2.2	500	2.0

TA 219920

**LUBRICANT • INTERVAL**

**INTERVAL • LUBRICANT**

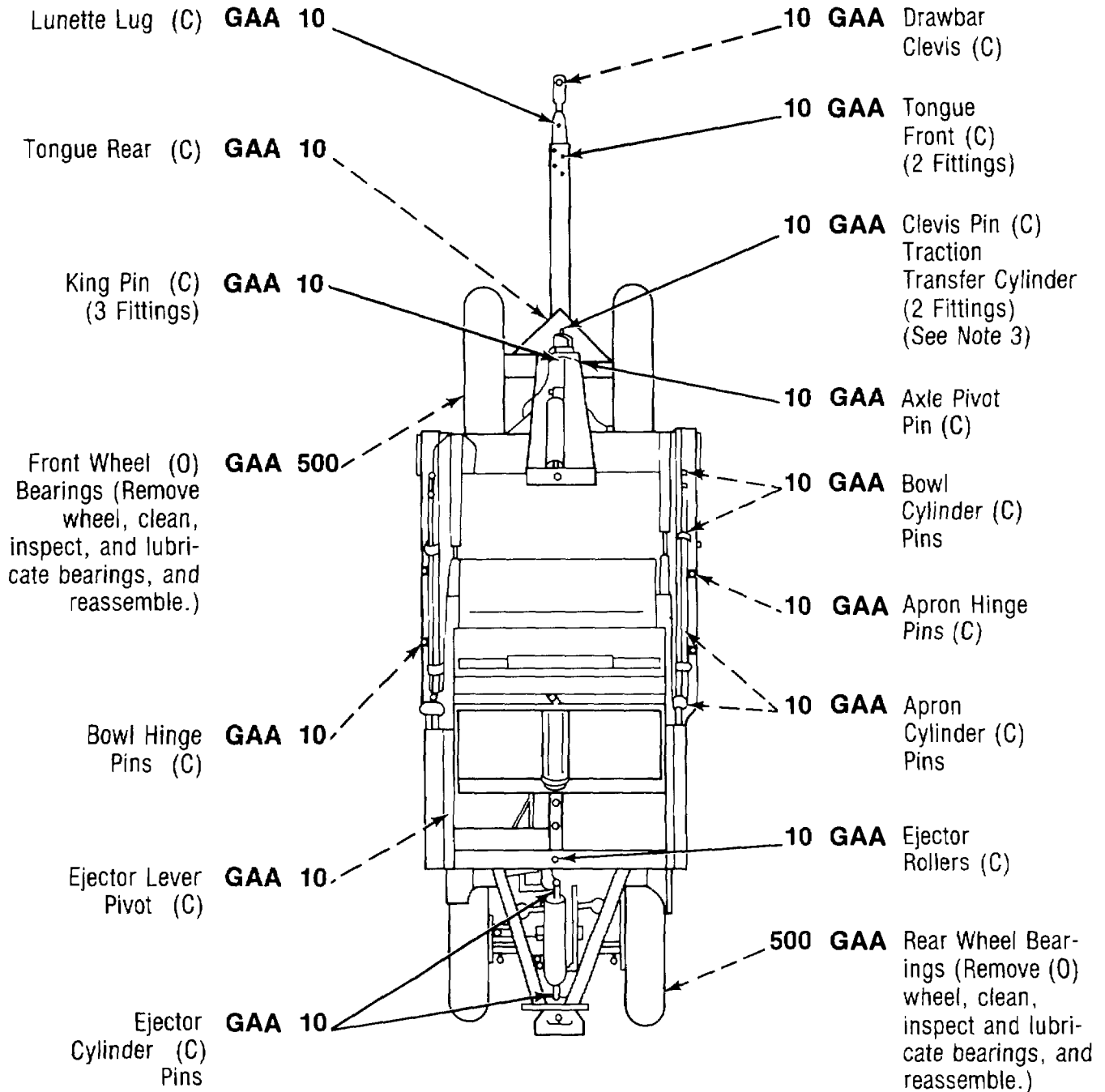

**PLAN VIEW**

TA 219921

\* KEY -

LUBRICANTS	CAPACITY	EXPECTED TEMPERATURES			INTERVALS
		Above +15°F (Above -9°)	+40°F to -15° F (+4° to -26°)	+40°F to -65°F (+4° to -54°)	
<b>OE/ - HDO</b> - Lubricating Oil, Internal Combustion Engine, Tactical Service  <b>OEA</b> - Lubricating Oil, Internal Combustion Engine, Arctic - Oil Can Points (See Note 2)		OE/HDO 30	OE/HDO 10	OEA (See Note 1)	For Arctic operation refer to FM 9-207  Intervals given are in hours of normal operation.
<b>GAA</b> - Grease, Automotive and Artillery		ALL TEMPERATURES			

\*See Note 4 for lubricant specification number.

NOTES:

- FOR OPERATION OF EQUIPMENT in PROTRACTED COLD TEMPERATURES BELOW -15°F (-26°C). Remove lubricants prescribed in Key for temperatures above -150F (-26°C). Relubricate with lubricants specified in Key for temperatures below -150°F (-26°C). If OEA lubricant is required to meet the temperature ranges prescribed in the Key, OEA lubricant is to be used in place of OE/HDO-10 lubricant for all temperature ranges where OE/HDO-10 is specified in the Key.
- OIL CAN POINTS. Each 10 hours lubricate control linkage, pins and devises, and all exposed adjusting threads with OE/HDO.
- TRACTION WEIGHT TRANSFER CYLINDER. Every 10 hours lubricate the bottom cylinder and pivot pins and top cylinder pin, not shown, with GAA.
- LUBRICANTS. The following is a list of lubricants with military symbols and applicable specification numbers.

OE/HDO	MIL-L-2104
GAA	M IL-G-10924
OEA	MIL-L-46167
(SD), Type II	P-D-680

Copy of this Lubrication Order will remain with the equipment at all times, instructions contained herein are mandatory.

By order of the Secretary of the Army:

JOHN A. WICKHAM, JR.  
*General, United States Army*  
 Chief of Staff OFFICIAL:

ROBERT M. JOYCE  
*Major General, United States Army*  
 The Adjutant General

DISTRIBUTION:

To be distributed in accordance with DA Form 12-25B, Operator and Organizational maintenance requirements for Scrapers.

TA 219922



This fine document...

Was brought to you by me:



## [Liberated Manuals -- free army and government manuals](#)

Why do I do it? I am tired of sleazy CD-ROM sellers, who take publicly available information, slap “watermarks” and other junk on it, and sell it. Those masters of search engine manipulation make sure that their sites that sell free information, come up first in search engines. They did not create it... They did not even scan it... Why should they get your money? Why are not letting you give those free manuals to your friends?

I am setting this document FREE. This document was made by the US Government and is NOT protected by Copyright. Feel free to share, republish, sell and so on.

I am not asking you for donations, fees or handouts. If you can, please provide a link to [liberatedmanuals.com](http://liberatedmanuals.com), so that free manuals come up first in search engines:

<A HREF=<http://www.liberatedmanuals.com/>>Free Military and Government Manuals</A>

- Sincerely  
Igor Chudov  
<http://igor.chudov.com/>
- [Chicago Machinery Movers](#)