

**LUBRICATION ORDER**

**LO 10 3930-609-12**

23 March 1984

(Supersedes LO 10-3930-609-12, 12 JUNE 1969)

**TRUCK, FORKLIFT, ELECTRIC, SOLID RUBBER**

**TIRES; 2,000 LBS CAPACITY, 144 IN. LIFT**

**(BAKER MODEL FTD-020-EE-SS)**

**(ARMY MODEL MHE 204)**

**(NSN 3930-00-935-7864)**

Reference: TM 10-3930-609-12 and FEDERAL SUPPLY CATALOG C9100-IL

Hard time intervals and the related man hour times are based on normal operation. The man-hour time specified is the time you need to do all the services prescribed for a particular interval. Change the hard time interval if your lubricants are contaminated or if you are operating the equipment under adverse operating conditions, including longer-than-usual operating hours. The hard time interval may be extended during periods of low activity. If extended, adequate preservation precautions must be taken.

**WARNING**

**1**

Dry cleaning fluid is flammable. Do not use near a flame or excessive heat. Use only with adequate ventilation. Avoid prolonged breathing of vapors and minimize skin contact.

Clean parts or fittings with dry cleaning solvent (SD), Type II or equivalent. Dry before lubricating. Dotted arrow shafts indicate lubrication on both sides of equipment. A dotted circle indicates a drain below. Relubricate all items found contaminated after fording or washing.

The lowest level of maintenance authorized to lubricate a point is indicated by one of the following symbols as appropriate: Operator/Crew (C); and Organizational Maintenance (O).

**Reporting errors and recommending Improvements.** You can help improve this manual. If you find any mistakes, or if you know of a way to improve the procedures, please let us know. Mail your letter or DA Form 2028 (Recommended Changes to Publications and Blank Forms) direct to: Commander, US Army Tank-Automotive Command, ATTN: DRSTA-MB, Warren, MI 48090. A reply will be furnished to you.

\*The time specified is the time required to perform all services at the particular interval.

<b>*TOTAL MAN-HOURS</b>	
<b>INTERVAL</b>	<b>MAN-HOURS</b>
<b>50</b>	<b>0.4</b>
<b>250</b>	<b>2.1</b>
<b>1000</b>	<b>2.8</b>

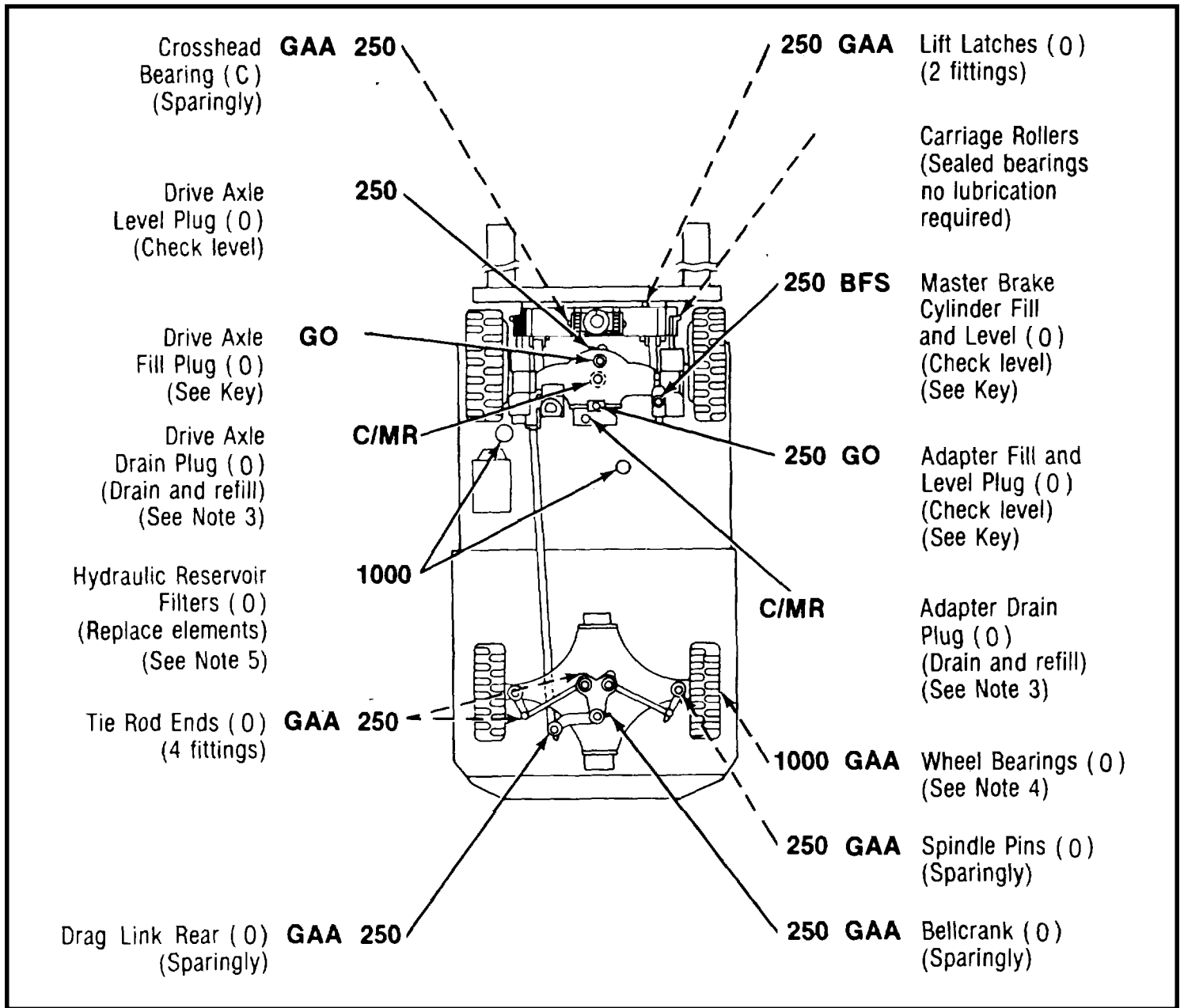

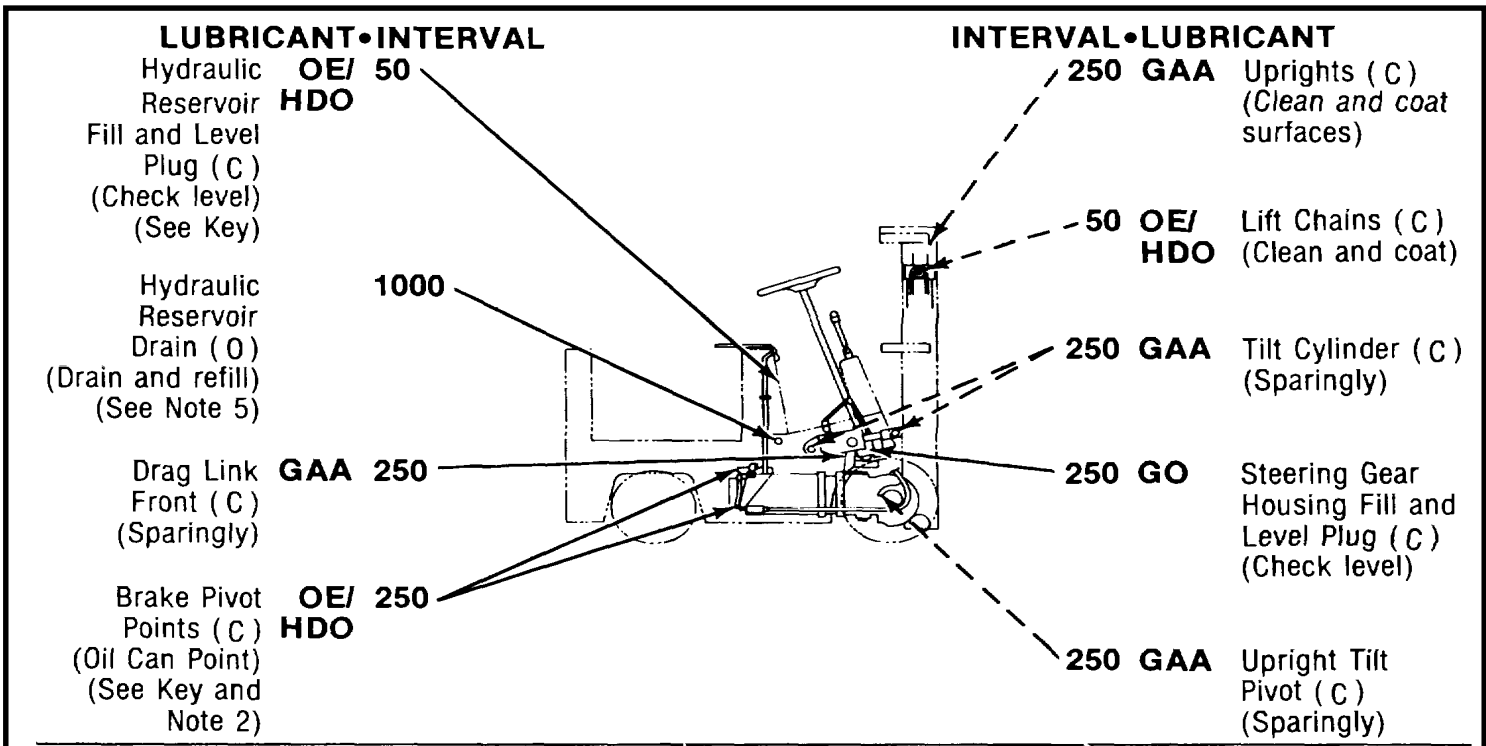

LUBRICANTS	CAPACITY	EXPECTED TEMPERATURES			INTERVALS
		Above +15°F (Above -9°C)	+40° to -15°F (+4° to -26°C)	+40° to -65°F (+4° to -54°C)	
<b>OE/ HDO</b> - Lubricating Oil, Internal Combustion Engine, Tactical Service  <b>OEA</b> - Lubricating Oil, Internal Combustion, Arctic  - Hydraulic Reservoir - Oil Can Points (See Note 2)	20 qts. (18.92 L)	<b>OE/HDO 10</b>	<b>OE/HDO 10</b>	<b>OEA</b> (See Note 1)	<b>For Arctic operation refer to FM 9-207</b>  C/MR-Condition Monitor  Intervals given are in hours of normal operation.
<b>GO</b> - Lubricating Oil, Gear, Multipurpose - Adapter Assembly - Drive Axle Gearcase - Steering Gear Assembly	2 pts. (0.946 L) 2 pts. (0.946 L) 1 pt. (0.473 L)	<b>GO 80W/90</b>	<b>GO 80W/90</b>	<b>GO 75W</b>	

\*See note 6 for lubricant specification number.

LUBRICANTS	CAPACITY	EXPECTED TEMPERATURES			INTERVALS
		Above +15°F (Above -9°C)	+40° to -15°F (+4° to -26°C)	+40° to -65°F (+4° to -54°C)	
<b>BFS</b> - Brake Fluid, Silicone, Automotive  - Brake Master Cylinder		ALL TEMPERATURES			
<b>GAA</b> - Grease, Automotive and Artillery		ALL TEMPERATURES			

\*See Note 6 for lubricant specification number.

1. FOR OPERATION OF EQUIPMENT IN PROTRACTED COLD TEMPERATURES BELOW -150F (-260C). Remove lubricants prescribed in Key for temperatures above -150F (-260C). Relubricate with lubricants specified in Key for temperatures below -15°F (-260C).

If OEA lubricant is required to meet the temperature ranges prescribed in the Key, OEA lubricant is to be used in place of OE/HDO-10 lubricant for all temperature ranges where OE/HDO-10 is specified in the Key.

2. OIL CAN POINTS. Each 250 hours lubricate seat brake and hand brake linkage, accelerator pivot points, battery rollers and all exposed adjusting threads with OE/HDO.

3. DRIVE AXLE-ADAPTER. Check level each 250 hours. Change gear lubricant only when required by maintenance repair action, contamination by water, or other foreign material. After refill, operate for five minutes, check for leaks and bring oil level to level plug opening.

4. WHEEL BEARINGS. Each 1000 hours, remove wheels, clean and inspect all parts, replace damaged or worn parts, repack bearings, and assemble.

5. HYDRAULIC RESERVOIR AND FILTERS. Each 50 hours check oil level. Maintain oil level to full mark. Each 1000 hours drain reservoir, remove filter

elements, clean filter shells, and install new filter elements. Reinstall drain plug and fill reservoir. Operate hydraulic system for 5 minutes, check for leaks, check oil level and bring to full mark.

6. LUBRICANTS. The following is a list of lubricants with military symbols and applicable specification numbers.

OE/HDO MIL-L-2104  
 GO MIL-L-2105  
 GAA MIL-G-10924  
 OEA MIL-L-46167  
 BFS MIL-B-46176  
 (SD), Type II P-D-680

Copy of this Lubrication Order will remain with the equipment at all times, instructions contained herein are mandatory.

By order of the Secretary of the Army:  
 JOHN A. WICKHAM, JR.  
 General, United States Army  
 Chief of Staff

OFFICIAL:  
 ROBERT M. JOYCE  
 Major General, United States Army  
 The Adjutant General

DISTRIBUTION:  
 To be distributed in accordance with  
 DA Form 12-25A, Operator and Organizational maintenance requirements for  
 Fork Lift Trucks

RECOMMENDED CHANGES TO EQUIPMENT TECHNICAL PUBLICATIONS



THEN... JOT DOWN THE DOPE ABOUT IT ON THIS FORM, CAREFULLY TEAR IT OUT, FOLD IT AND DROP IT IN THE MAIL!

**SOMETHING WRONG WITH THIS PUBLICATION?**

FROM: (PRINT YOUR UNIT'S COMPLETE ADDRESS)

DATE SENT

PUBLICATION NUMBER

PUBLICATION DATE

PUBLICATION TITLE

BE EXACT... PIN-POINT WHERE IT IS

PAGE NO.	PARA-GRAPH	FIGURE NO.	TABLE NO.
----------	------------	------------	-----------

IN THIS SPACE TELL WHAT IS WRONG AND WHAT SHOULD BE DONE ABOUT IT:

TEAR ALONG PERFORATED LINE

PRINTED NAME, GRADE OR TITLE, AND TELEPHONE NUMBER

SIGN HERE:

DA FORM 2028-2  
1 JUL 79

PREVIOUS EDITIONS ARE OBSOLETE.

P.S.—IF YOUR OUTFIT WANTS TO KNOW ABOUT YOUR RECOMMENDATION MAKE A CARBON COPY OF THIS AND GIVE IT TO YOUR HEADQUARTERS.

**PIN: 012123-000**

This fine document...

Was brought to you by me:



## [Liberated Manuals -- free army and government manuals](#)

Why do I do it? I am tired of sleazy CD-ROM sellers, who take publicly available information, slap “watermarks” and other junk on it, and sell it. Those masters of search engine manipulation make sure that their sites that sell free information, come up first in search engines. They did not create it... They did not even scan it... Why should they get your money? Why are not letting you give those free manuals to your friends?

I am setting this document FREE. This document was made by the US Government and is NOT protected by Copyright. Feel free to share, republish, sell and so on.

I am not asking you for donations, fees or handouts. If you can, please provide a link to [liberatedmanuals.com](http://liberatedmanuals.com), so that free manuals come up first in search engines:

<A HREF=<http://www.liberatedmanuals.com/>>Free Military and Government Manuals</A>

- Sincerely  
Igor Chudov  
<http://igor.chudov.com/>
- [Chicago Machinery Movers](#)