

**LUBRICATION
ORDER**

L010 3530 203-10-3
22 OCTOBER 1965

**CLOTHING, REPAIR SHOP, TRAILER MTD, ARMY MODEL SPV34, YORK ASTRO MODEL D8700337, TEXTILE REPAIR SHOP, TRAILER MTD,
ARMY MODEL SPV35, YORK ASTRO MODEL D8700447, MACHINE, SEWING, DARNING SINGER MODEL 47W70**

Reference LO 10-3530-203-10-1 and 2, C9100-IL

Intervals are based on normal hours of operations. Reduce to compensate for abnormal operations and severe conditions. During inactive periods sufficient lubrication must be performed for adequate preservation.

Clean parts with SOLVENT dry cleaning. Dry before lubricating.

Apply two to three drops of LO at each friction point unless otherwise noted.

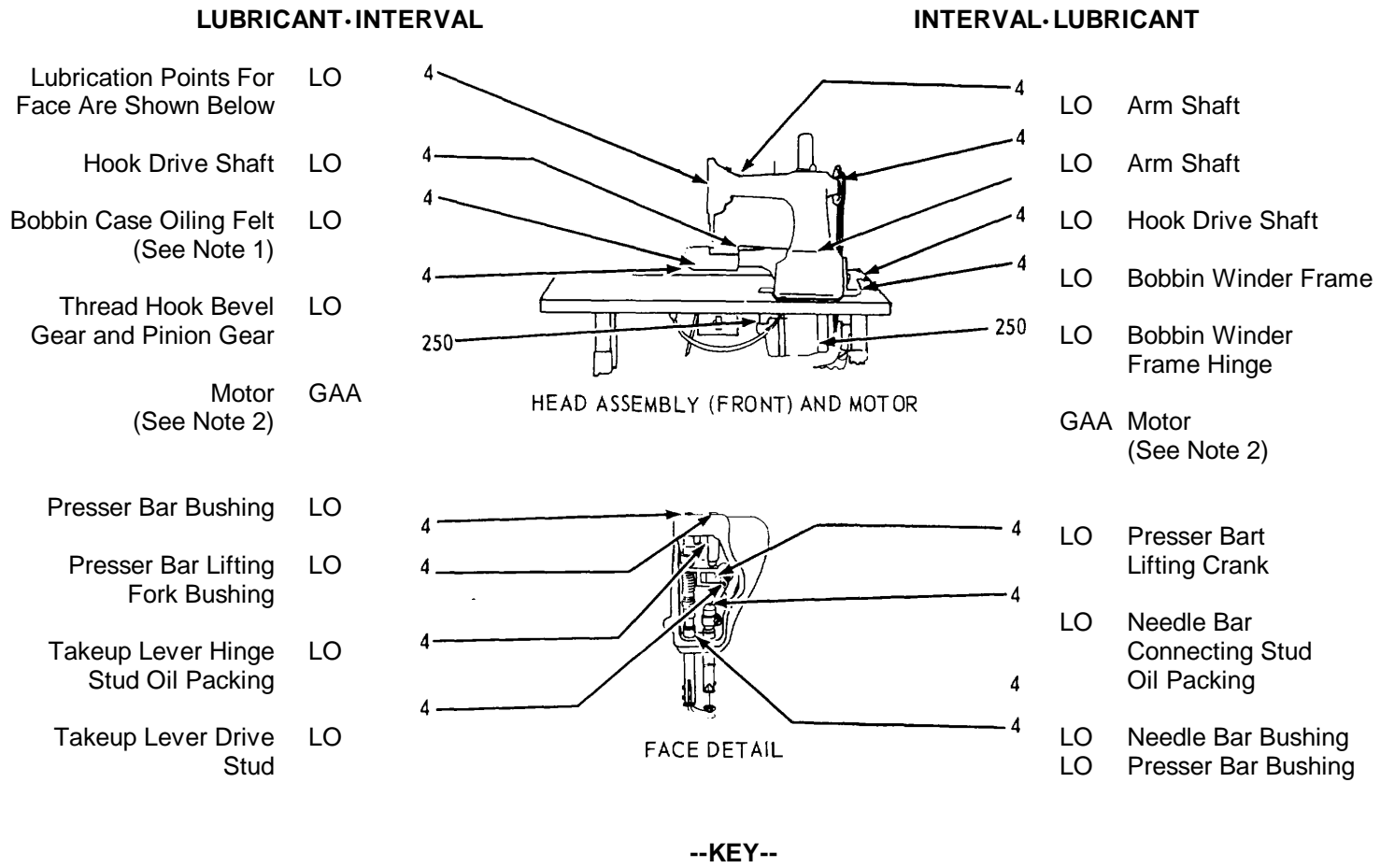

| LUBRICANTS | EXPECTED TEMPERATURES | INTERVALS |
|---|-----------------------|--|
| LO Lubricating Oil, General Purpose | all temperatures | Intervals given are in hours of normal |
| GAA Grease, Automotive and Artillery | all temperatures | operation. |

NOTES:

1. **BOBBIN CASE OILING FELT.** Keep felt pad on the side of the bobbin case to lubricate the hook race. When this pad is wet with oil it appears nearly black; when it appears light green it is dry. Check pad for oil each time a bobbin is replaced and oil if necessary.

2. **MOTOR.** Lubricate oil points with two or three drops of L.O. every 4 hours. Fill grease cups as necessary with GAA grease. Turn grease cups clockwise three turns every 250 hours.

Copy of this Lubrication Order will remain with the equipment at all times; instructions contained herein are mandatory.

BY ORDER OF THE
SECRETARY OF THE ARMY:

HAROLD K. JOHNSON,
General, United States Army
Chief of Staff.

OFFICIAL:

J. C. LAMBERT,
Major General, United States Army,
The Adjutant General.

LO 10-3530-203-10-3 DISTRIBUTION: Active Army: USASA (1); DCSLOG (1); CNGB (1); CAR (1); USAMC (12); USACDCEC (10); USAMOCOM (2); USAWECOM (5); USAMICOM (5); USAMUCOM (5); USAECOM (5); USATECOM (5); USASMC (1); USCONARC (2); CofEngrs (6); CofSptS (1); Dir of Trans (1); CC-E (1); ARADCOM 12; ARADCOM (2); OS Mai Comd (3); LOGCOMD (1); MDW (1); Armies (5); NLAIS (4); USASPTCP (10); USAMEC 146; Svc Colleges (2); Br Svc Sch (2) except USAQMS (10); USAOMTC (4); Mbl Equip Moa Fid Ofc (Ft Lee) (2); USMA (1); A Dep (4); POE (2); USA Tml Comds (2); Army Tml (2); Arsenal (2); PG (2); Instl (2); QM Fld Maint Shops (2); Ft Knox Fld Maint Shops (10). Units org under fol TOE: (2 copies each); 10-105, 10-107, 10-445, 10-448, 10-500, 29-114, 29-124 and 29-206. NG: State AG (3). USAR: Same as Active Army except allowance is one copy to each unit. For explanation of abbreviations used, see AR 320-50.

RECOMMENDED CHANGES TO EQUIPMENT TECHNICAL PUBLICATIONS

SOMETHING WRONG WITH PUBLICATION



THEN...JOT DOWN THE DOPE ABOUT IT ON THIS FORM. CAREFULLY TEAR IT OUT, FOLD IT AND DROP IT IN THE MAIL.

FROM: (PRINT YOUR UNIT'S COMPLETE ADDRESS)

DATE SENT

PUBLICATION NUMBER

PUBLICATION DATE

PUBLICATION TITLE

BE EXACT PIN-POINT WHERE IT IS

IN THIS SPACE, TELL WHAT IS WRONG AND WHAT SHOULD BE DONE ABOUT IT.

PAGE NO.

PARA-GRAPH

FIGURE NO.

TABLE NO.

TEAR ALONG PERFORATED LINE

PRINTED NAME, GRADE OR TITLE AND TELEPHONE NUMBER

SIGN HERE

This fine document...

Was brought to you by me:



[Liberated Manuals -- free army and government manuals](#)

Why do I do it? I am tired of sleazy CD-ROM sellers, who take publicly available information, slap “watermarks” and other junk on it, and sell it. Those masters of search engine manipulation make sure that their sites that sell free information, come up first in search engines. They did not create it... They did not even scan it... Why should they get your money? Why are not letting you give those free manuals to your friends?

I am setting this document FREE. This document was made by the US Government and is NOT protected by Copyright. Feel free to share, republish, sell and so on.

I am not asking you for donations, fees or handouts. If you can, please provide a link to liberatedmanuals.com, so that free manuals come up first in search engines:

<A HREF=<http://www.liberatedmanuals.com/>>Free Military and Government Manuals

- Sincerely
Igor Chudov
<http://igor.chudov.com/>
- [Chicago Machinery Movers](#)